

**PLAN**

**NOTE:**  
Gauge shall be used to check PCD and tapped hole position

Riser will be required for roadway cover

See detail 1

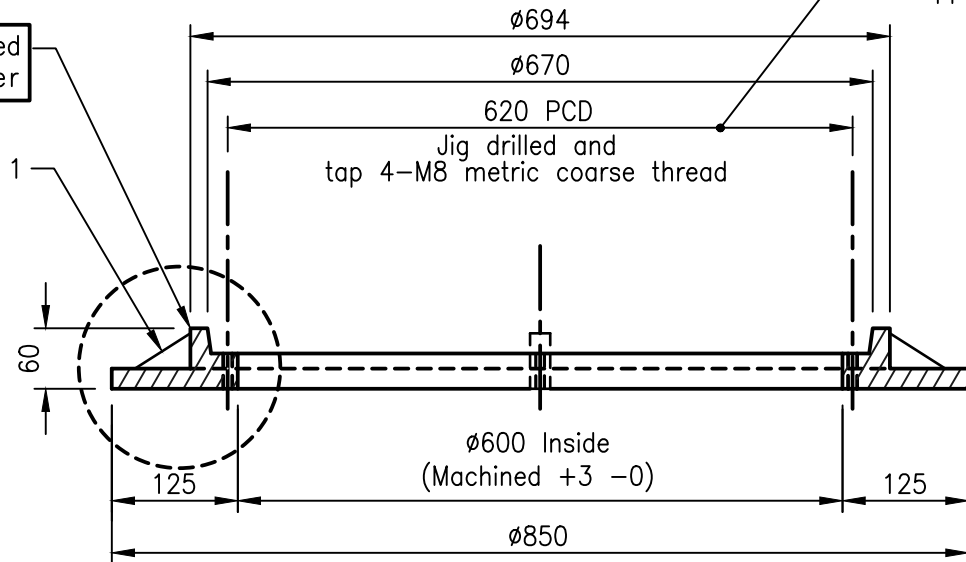

**SECTION**

These drawings have been developed in consultation between the participating Councils.  
BEFORE USE, the user shall confirm that the drawing has been adopted by the appropriate Council.

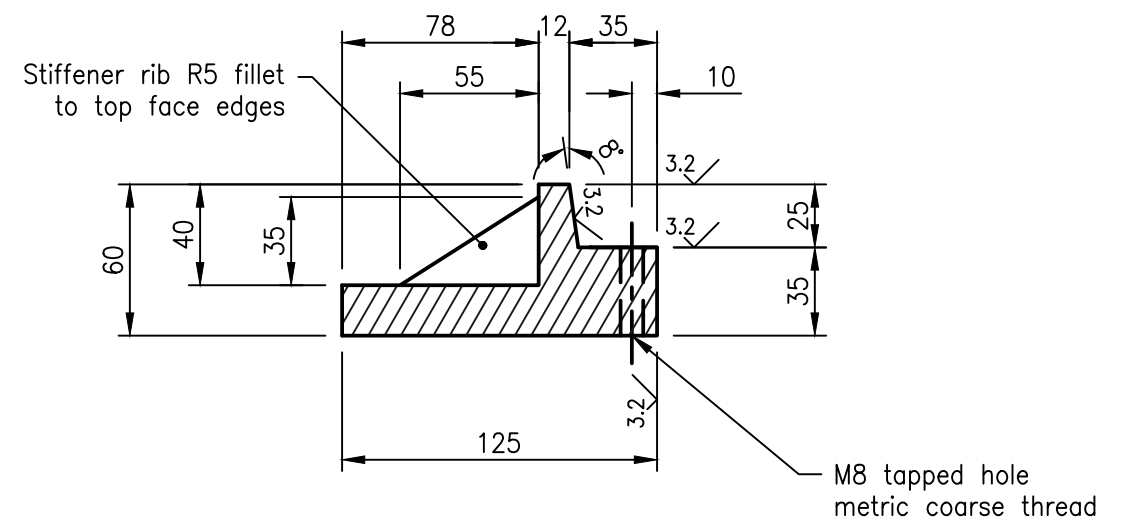

**DETAIL 1**

M8 tapped hole  
metric coarse thread

**NOTES:**

- All edges to be square.
- Casting to be free of burrs and pits.
- Material**  
Grey Cast iron (AS 1830)  
Tensile strength : >T220  
Hardness : 145-185 (HB)  
Design Load = 210kN (AS 3996)  
Mass = 59.5Kg
- Tolerances**  
Cast size  $\pm 1.00\text{mm}$   
Angle Profile  $\pm 0.25^\circ$   
Machined size  $\pm 0.125\text{mm}$   
Overall diameter of cover + 0mm-0.25mm  
DFT of coating 50  $\mu\text{m}$
- Machine surface symbol: 3.2
- All machined surfaces shall have a coating approved as fit for the purpose of providing a rust proof, non-stick and gas/water proof joint.
- Refer Std Dwg No DS-018 for manhole riser details.
- Refer Std Dwg No DS-019, DS-020 and DS-021 for manhole cover details.
- All dimensions are in millimetres unless shown otherwise.

| Rv. | DATE  | REVISIONS              |
|-----|-------|------------------------|
| C   | 06/14 | Review                 |
| B   | 03/14 | Amended Drawing Number |
| A   | 10/12 | ORIGINAL ISSUE         |

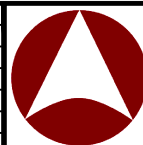

**INSTITUTE OF PUBLIC WORKS ENGINEERING AUSTRALASIA  
STANDARD DRAWINGS**

**MANHOLE FRAME  
(ROADWAY AND NON-ROADWAY)  
1050 TO 2100 DIAMETER**

**DS-015**

C  
B  
A  
Rv.