

COASTAL PATHWAY
SIGNAGE STYLE GUIDE
RFG 20802/2

ISSUE B • 27.06.2019



CONTENTS

Acknowledgements
Introduction

Section A
Wayfinding strategy

Section B
Graphic standards

Section C
Sign types

Section D
Sign specification

ACKNOWLEDGEMENTS

The Coastal Pathway Signage Style Guide has been prepared by Dot Dash Pty Ltd for the Sunshine Coast Council. The kind assistance of the following people is gratefully acknowledged;

Leigh Abernethy

Place Coordinator
Place Design and Standards
Transport and Engineering - Infrastructure Services
Sunshine Coast Council

Nigel Walker

Team Leader Integrated Transport
Integrated Transport Services
Transport and Engineering - Infrastructure Services
Sunshine Coast Council

Neil Blamey

Senior Open Space and Recreation Planner - Social Policy
Regional Strategy and Planning
Sunshine Coast Council

Claire Staines

Senior Landscape Architect
Project and Design (South)
Parks and Gardens - Infrastructure Services
Sunshine Coast Council

Aili Robinson

Senior Landscape Architect
Project and Design (South)
Parks and Gardens - Infrastructure Services
Sunshine Coast Council

INTRODUCTION

The aim of this project is to develop a signage guidelines manual that will assist all users including walkers, runners and cyclists on the Coastal Pathway. The pathway runs for 90 kilometres over the Sunshine Coast and will connect the different coastal towns and regions.

While these areas will have their own urban characters it is intended that the pathway signage system is a consistent element that threads these locations together. The new signage will also replace or upgrade the 3 different suites of signs developed by the 3 previous councils.

The Coastal Pathway will link Tewantin township in the north with Pelican Waters (Bells Creek) in the south. It covers both off-road and on-road environments, and split path networks (i.e. bicycles and pedestrians directed to different paths).

The manual describes the principles of the Wayfinding strategy, details of the various sign types required, followed by visual graphic standards and construction standards. A range of sign types has been developed for pedestrian and cyclist wayfinding only. Sign types include mapping, directional and regulatory information.

It is important that the signage manual be strictly followed to maintain consistency throughout the Coastal Pathway.

Any questions or special requirements must be referred to either Transport and Engineering Services or Parks and Gardens.

A

WAYFINDING STRATEGY

Characterisation of pathway
Framework for wayfinding
Typical site analysis
Supplementary sign types

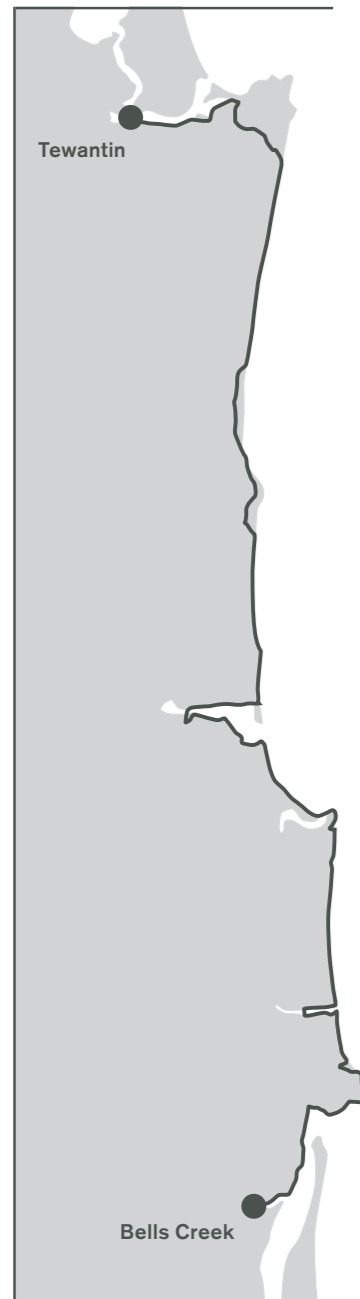

1 Pathway

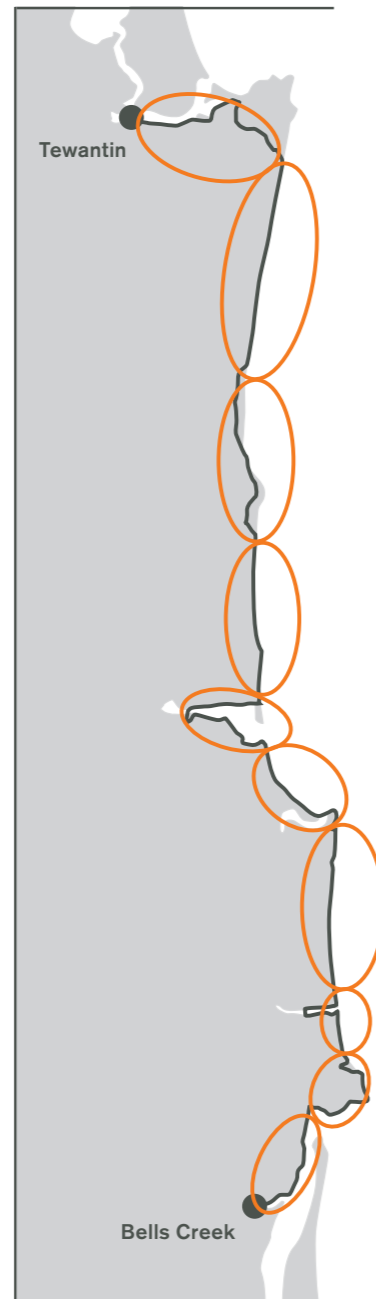

Spatial organisation

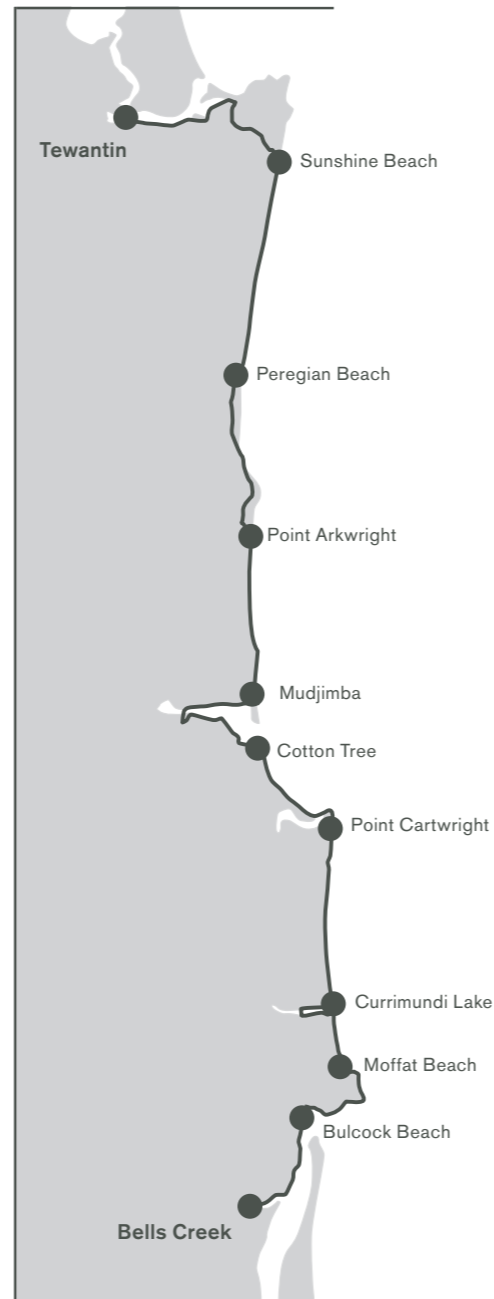

Major nodes

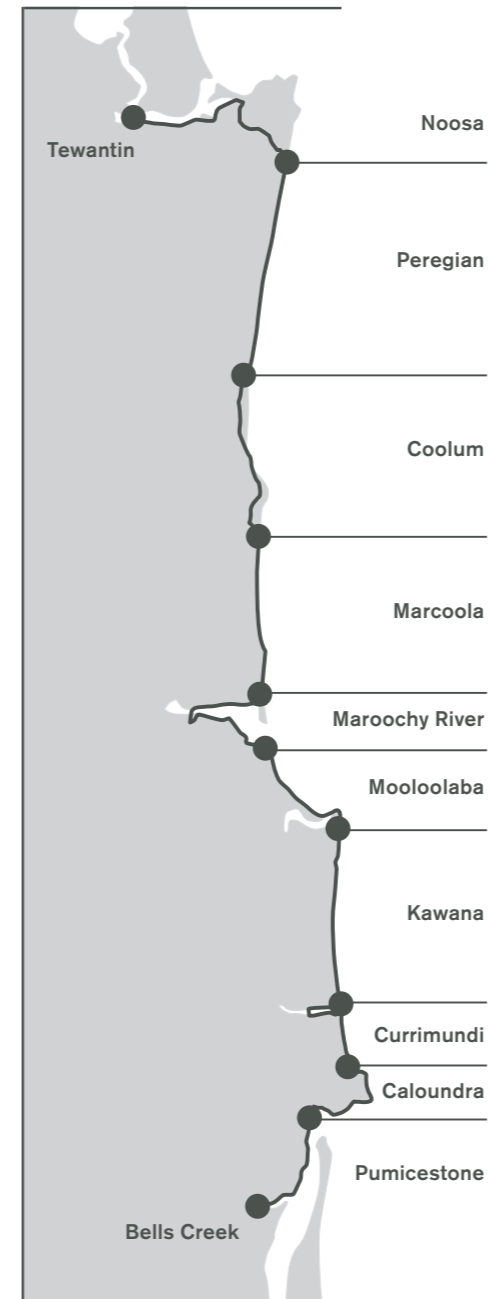

Connections

CHARACTERISATION OF THE PATHWAY

Connection identification

The 90 Sunshine Coast Council logo
The Logo should be reproduced on maps only. When using the map for printed collateral such as brochures, then the logo is to be accompanied with the phone number and web site. kms has been divided into 10 coastal zones. Each zone will be identified as a 'Connection'.

Connections lengths are appropriate for recreational outings such as a one day walking or casual cycle experience.

The start and finish of each Connection is determined by the location of existing nodes that are associated with activity centres, public transport and public car parks. These nodes will act as trail heads.

1 Pathway / 10 connections

- Assists in connectivity throughout the region.
- Promotes the notion of a 'community of communities'.
- Develops ownership of local areas.
- Spatial organisation for mental mapping of the network.

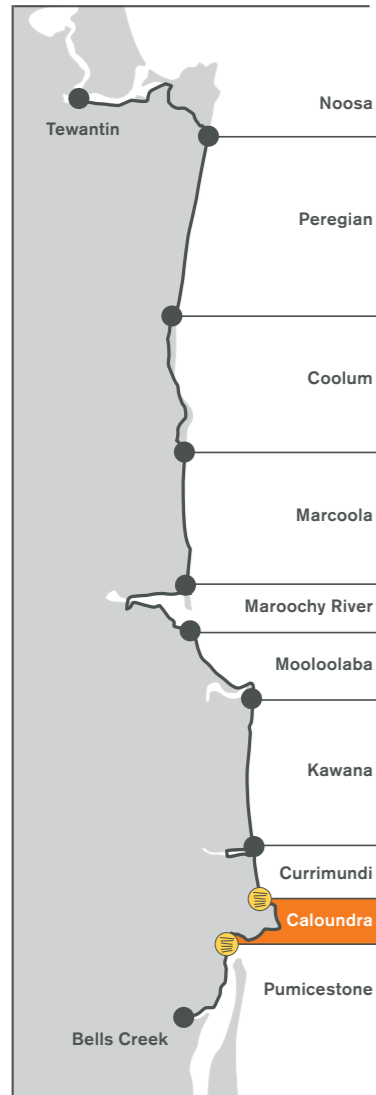

FRAMEWORK FOR WAYFINDING

The wayfinding strategy is based on typical patterns of movement along the pathway by the user groups.

The key principle is based on users navigating between landmarks and/or places of interest.

Connection identification

Connection identification signs are located at either end of each connection to act as a trail head providing start and end points. The signs also promote connectivity between each of the 10 connection zones.

Arrival to site

Information arrival signs are located at main gathering nodes along the pathway. These nodes are typically located at prominent landmarks and destinations. The majority of users will typically enter the pathway at these locations. The users will then proceed north or south from these points.

Intermediary links

Distance identification signs are located along the pathway between key arrival nodes – secondary landmarks, major intersections or places of interest. These are points where new users may enter the pathway. These signs provide connections to the arrival nodes.

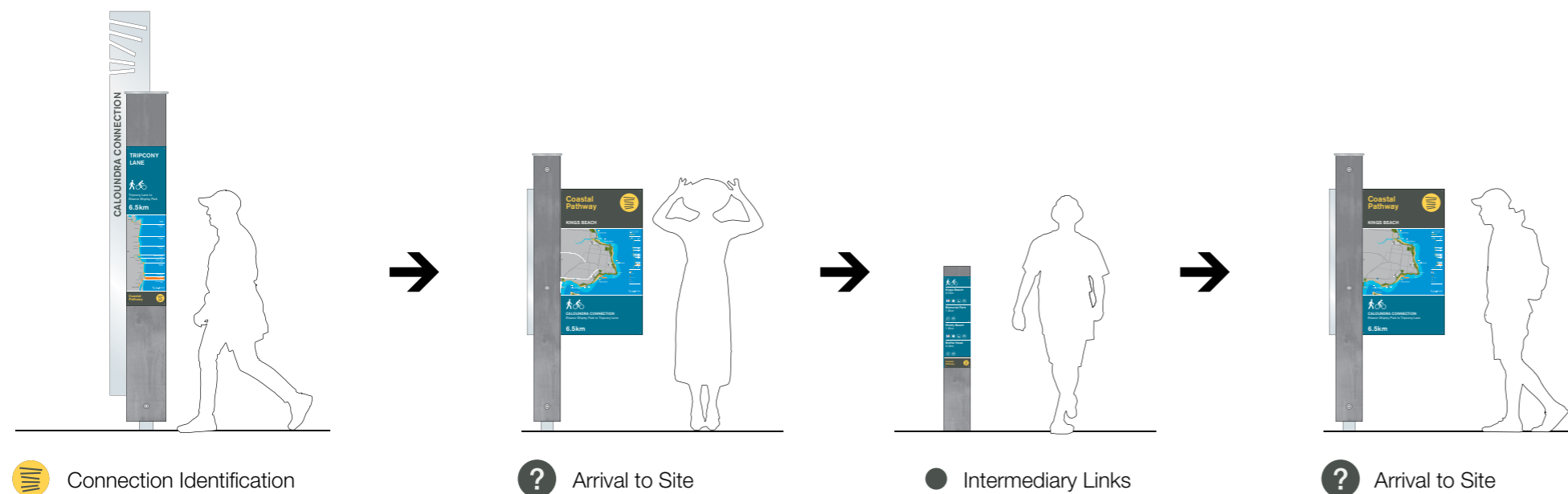



- Prominent public spaces/ landmarks/ destinations
- Business and activity centres
- Tourist accommodation precincts
- P Major public car parks

TYPICAL SITE ANALYSIS

Identifying locations for site arrival

Within each Connection it is important to understand how users arrive to the pathway.

Arriving by car

Most people arriving by car will park in public car parks. Public car parks are typically found within activity centres and near main destinations and landmarks such as patrolled beaches, parks, lookouts etc.

Arriving by public transport

The majority of public transport set downs and pick ups are generally located within activity centres and prominent public spaces.

Tourists

Accommodation precincts are typically found in close proximity to the coastline and main activity centres.

By foot of bicycle

Users immediate to the area will generally arrive via their closest access point. These points can be small open spaces such as parklands, beach access paths and streets.

Analysis studies

Step 1 - Analysis of key areas

Step 2 - Identify main gathering nodes

Step 3 - Identify optimal location within each node

SUPPLEMENTARY SIGN TYPES

The schematic study illustrates the strategy for the placement and content of supporting sign types. This group of sign types is to supplement the major Wayfinding sign types.

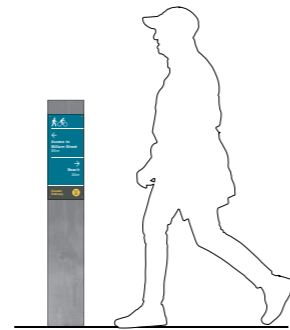

Directional sign

Located where there is possible ambiguity in the pathway route, including major junctions and open areas. Also used at pathway exits to the surrounding street network to promote safety and connectivity to community.



Warning information sign

Located where there is a change in pathway conditions that may endanger the user. Also used at locations where information is required to make aware certain conditions that may effect some user groups such as cross over points.

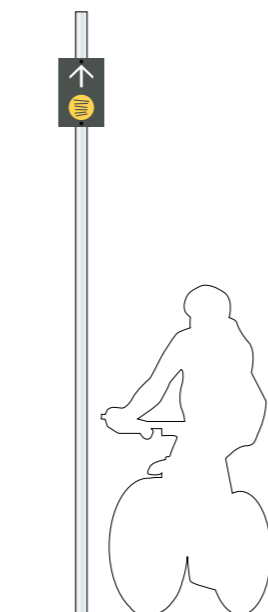

On-road identification sign

Located on the main road network to direct and identify the continuation of the pathway. To be used in conjunction with existing traffic/street sign structures.

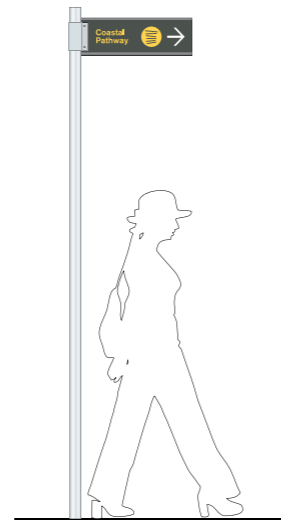

Directional finger blade
 Located in urban and park areas to direct and identify the pathway route at missing links. To be used in conjunction with existing traffic/street sign structures.

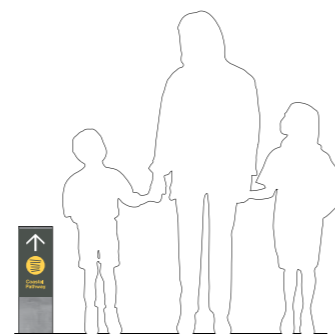

Directional bollard
 Located in park/natural areas to direct and identify the pathway route at missing links. To be used where there is no suitable infrastructure to mount a Directional finger blade.

SUPPLEMENTARY SIGN TYPES

The schematic study illustrates the strategy for the placement and content of supporting sign types. This group of sign types is to supplement the major Wayfinding sign types.

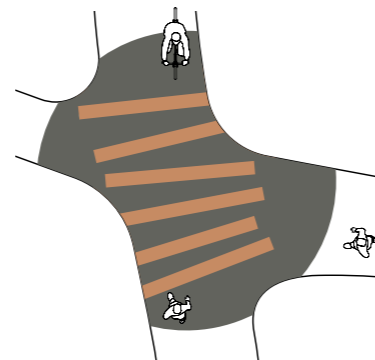

Cross over graphic
 Located at potential conflict zones along the pathway. These are usually at major intersections that provide access to beaches, parks, buildings and adjacent roads.

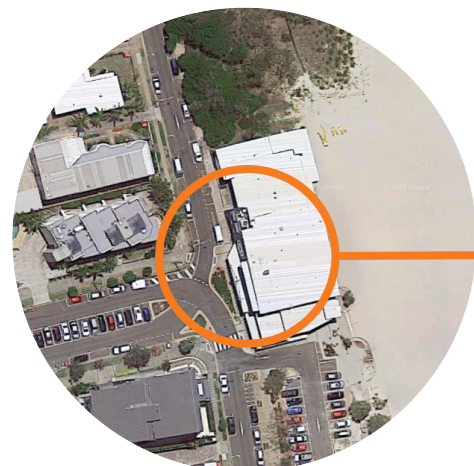

Behavioural sign
 Located regularly along pathway to advise all user groups of their behavioural obligations. Used to support cross over ground graphics on all approaches to intersection.

BEHAVIOURAL SIGN TYPES

This group of sign types are used to encourage all users of the pathway to consider the needs of others. To inform cyclists to give way to pedestrians, go slow in congested areas and sound their bell when approaching. As well as encouraging pedestrians not to block the path and to be aware of runners, cyclists and other users.

Should regulatory information be required, use discretion as to which sign type the information should be included so as not to create too many signs in parks. The preference is to include permitted activities.

B

GRAPHIC STANDARDS

Typeface

Type detailing

Pictograms - standard facilities

Pictograms - services

Arrows

Nomenclature

Colours

Map standards - site arrival

Map standards - connections

Regular

ABCDEFGHIJKLMNOPQRSTUVWXYZ

abcdefghijklmnopqrstuvwxyz

1234567890

Berthold Akzidenz Grotesk Regular

Medium

ABCDEFGHIJKLMNOPQRSTUVWXYZ

abcdefghijklmnopqrstuvwxyz

1234567890

Berthold Akzidenz Grotesk Medium

TYPEFACE

Although Sunshine Coast Council's corporate typeface is Arial, the typeface Berthold Akzidenz Grotesk has been selected and approved to be used in all signage within this document. Typographical qualities of Berthold Akzidenz Grotesk include broad characters, large lowercase x-heights, generous ascenders and descenders, even stroke widths and adequate counter spaces within the bowl of the circular letterforms. These characteristics provide for very good legibility when read on signage within the urban landscape.

Font files can be sourced from either Civil Works Services (Anthony Heir) or Media and Public Relations (Joseph Stevenson).

X-height

Cap X-height
The distance between the baseline and the top of an 'X' capital letter

Caloundra

Letterspacing (+10)

Bulcock Beach
Moffat Beach

Title case

TRIPCONY LANE
ELEANOR SHIPLEY PARK

Upper case

TYPE DETAILING

Type size

Text size on all signs has been determined based on ideal viewing distances and should be adhered to wherever possible. Each sign type drawing has documented the heights which relate to the particular use of each sign. Refer to the sign type drawing for further detail.

Cap X-height

For accuracy in layout of text on signs, the height of the capital letter 'X' should be used instead of the point size of the font. This measurement is always shown in millimetres unless otherwise stated.

Letterspacing

Letterspacing adds space between letterforms to open up text. The addition of minimal letterspacing can increase the legibility, and readability. Added whitespace around the characters allows the individual characters to emerge and be recognized more quickly.

Title case

Title case is to be used when identifying a destination, facility or locality.

Upper case

When uppercase is to be used, this will be specified as part of the design on the relative sign type drawing. Refer to sign type graphic layouts for when to use upper case.

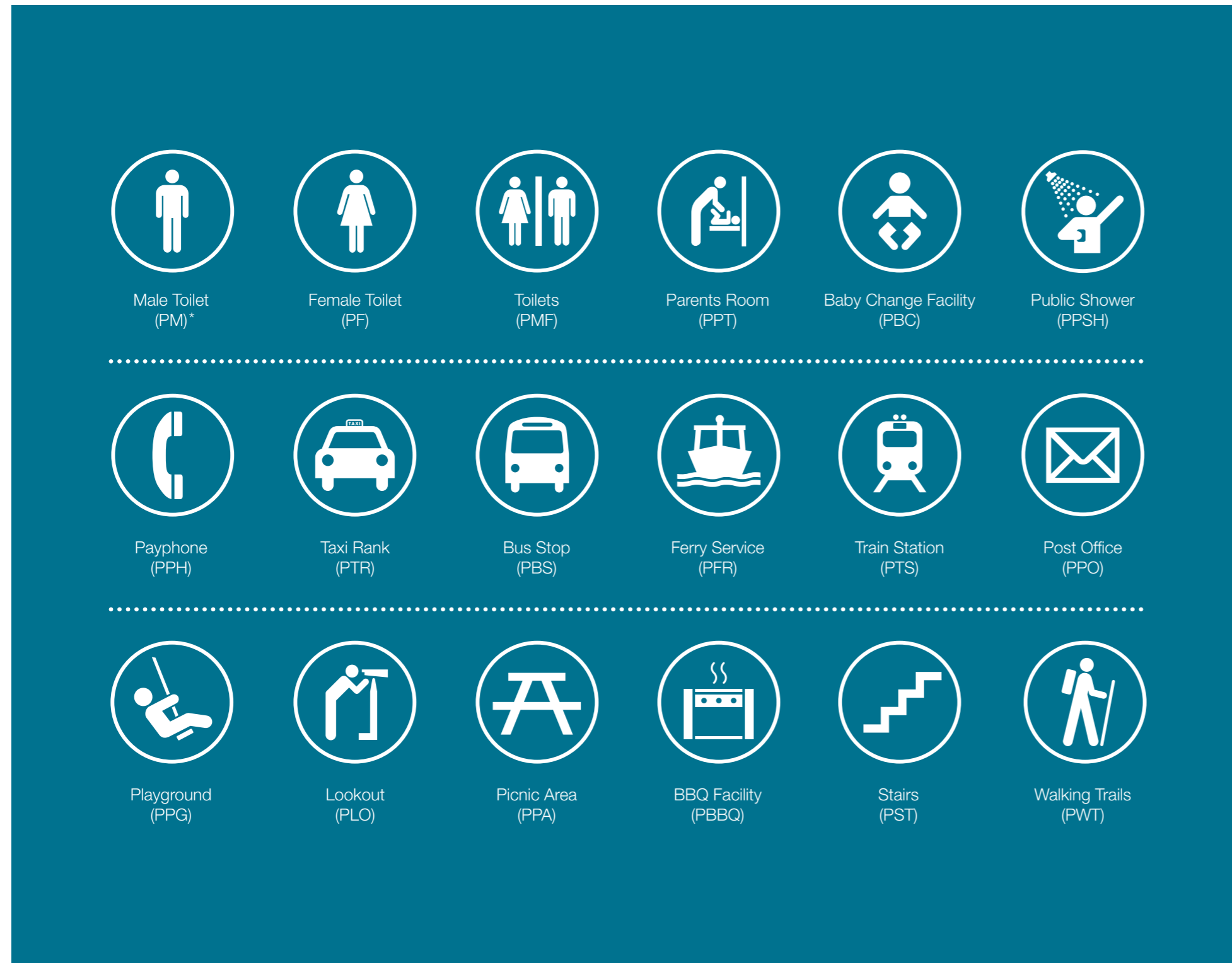

* Represents individual code for each pictogram.
To be used when ground truthing and specifying on sign schedules.

PICTOGRAMS AND SYMBOLS

STANDARD FACILITIES

Pictograms should be used to identify specific services and facilities. The use of easily recognised international pictograms enables the signs to communicate to a diverse multicultural audience. All pictograms should be supported by English text where possible. The pictograms are from the suite known as International Symbol Signs System, developed by the American Institute of Graphic Arts (AIGA) and Society of Environmental Graphic Design (SEGD). This suite of pictograms was developed to bring some order to the proliferation of pictograms being used by many different international organisations. This suite has been adopted in many countries and are recognised world wide. These pictograms are in line with international standards and can generally be understood as stand-alone messages. When used, pictograms should be scaled proportionately. All pictograms should be used with discretion, as over-use may lead to visual clutter, and confusion. Pictograms for use on all directional, identification and information signs are as illustrated. The text label shown below each pictogram is used for identification purposes. It should not be used together with the pictogram on a sign.

Council will supply a link to the pictogram and symbol library on the intranet. Alternatively contact Civil Works Services (Anthony Heir).

Safety

If safety pictograms are required, refer to AS 1319 Safety Signs for the Occupational Environment. For clarity, prohibitive pictograms are designed with the red line behind the symbol.

Colour swatches

White symbol and stroke on PMS 315C

Supplied artwork

All pictograms to be used as per .eps standards.
Never attempt to re-create pictograms.



PICTOGRAMS AND SYMBOLS

SERVICES

Tourist information

PMS 109C symbol
 PMS 2945C Background with White stroke

Accessible

PMS 2945C Background with White stroke
 White symbol

Patrolled beach

PMS 136C and PMS 186C Flags
 PMS 2945C Background with White stroke
 White symbol

Police station

PMS 2945C Background with White stroke
 White symbol

First aid / Medical centre

PMS 394C Background with White stroke
 White symbol

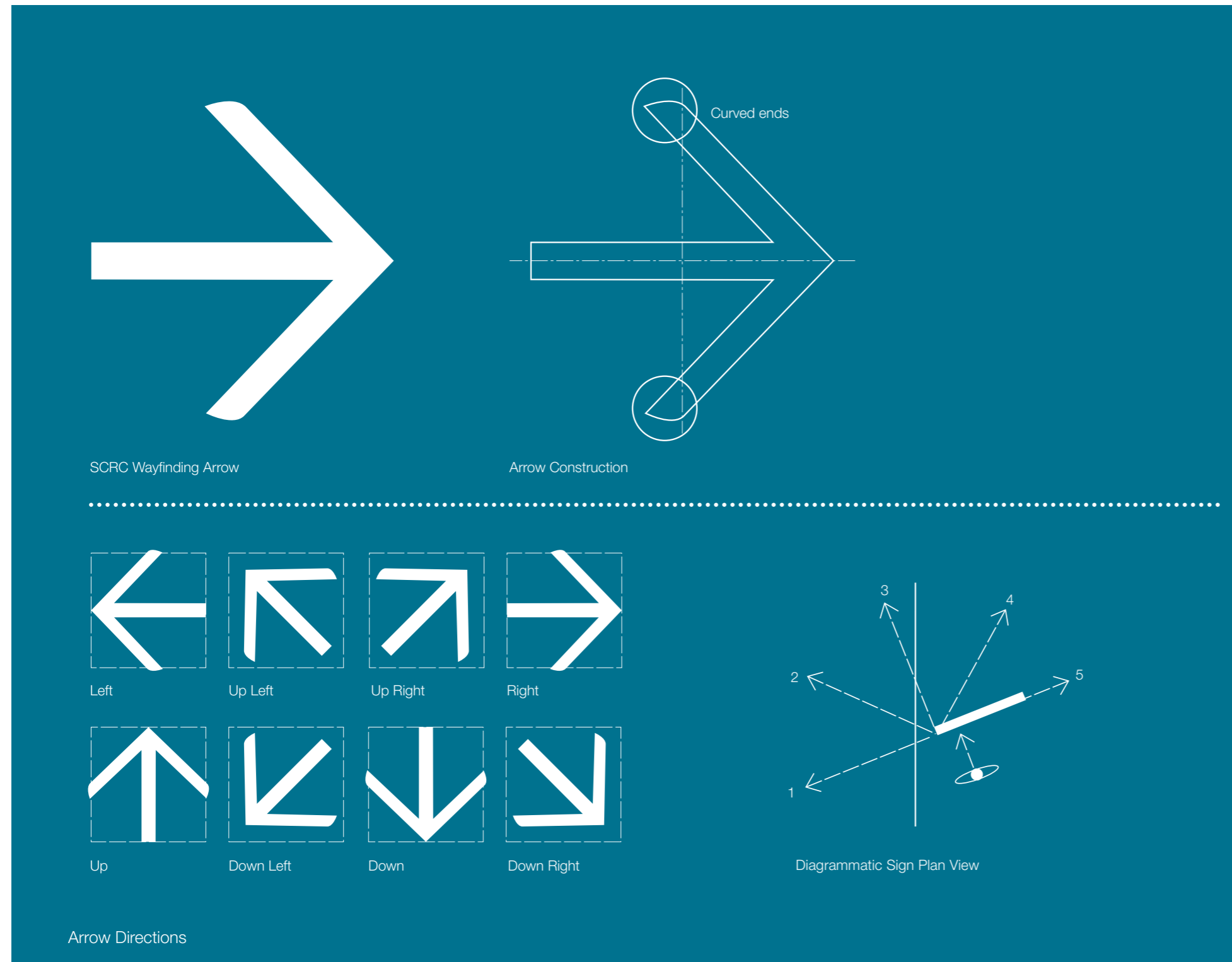

ARROWS

Standard arrows

Arrows play a major role in Wayfinding. To fulfil their purpose in the most effective manner, arrows must be used consistently. A specific arrow type has been chosen to complement the font Berthold Akzidenz Grotesk. This arrow type should be used in all directional signs.

Arrow directions

Up pointing arrow is used to direct forward. Right and Left pointing arrows direct to destinations that require pedestrians to turn right or left, either at the sign or immediately after the sign. Diagonal arrows direct diagonally up or diagonally down when located next to stairs or ramps. In other locations they direct diagonally ahead. Diagonal arrows may never be used to direct diagonally backwards. Down pointing arrow should only be used when the sign is above the destination.

Arrow bounding box

A square bounding box has been included in these arrow drawings as guides for the correct alignment of arrows and text. Note that the horizontal and vertical arrows extends beyond the box boundaries. After setting arrows and text, when it is no longer required, remember to remove the bounding box from the graphic layout.

Arrow size

The ratio between the size of the arrow and the text it is associated with must always be maintained. This will be specified as part of the design on the relative sign type drawing.

Arrow usage

A single arrow is required for each direction, not for each destination.

Supplied artwork

All arrows to be used as per .eps standards. Never attempt to re-create arrows.

Noosa**Peregian****Coolum****Marcoola****Maroochy River****Mooloolaba****Kawana****Currimundi****Caloundra****Pumicestone**

Connection names for Map sign panels

125m

5.3km

Lookout

Taxi Rank

Toilets

Telephone

Typical messaging for generic destinations

Dicky Beach**Moffat Beach****Tooway Creek****Eleanor Shipley Park****Moffat Head****Wickham Point**

Always provide the full (correct) name when identifying a specific landmark or destination

NOMENCLATURE

Nomenclature relates to the wording of the signs, as well as the tone of the messages. It is to be applied consistently throughout the Pathway.

This vocabulary needs to be used consistently not only on the signs, but also in all communications and web sites.

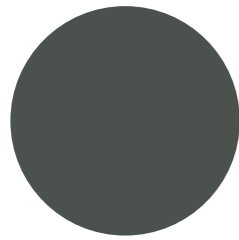

Dulux Woodland Grey
PMS 425C

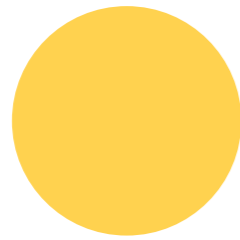

PMS 122C

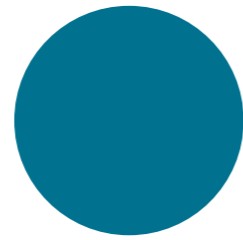

PMS 315C

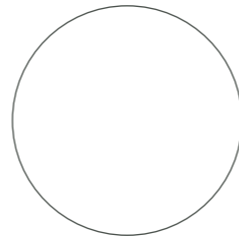

White

Coastal Pathway Branding Colours

Sign Panel Colours

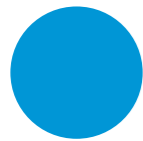

PMS 2925C

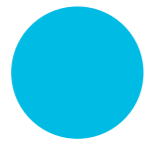

PMS 306C

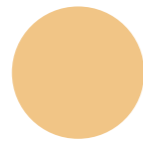

PMS 7509C

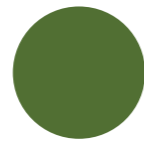

PMS 371C



PMS Grey 6C

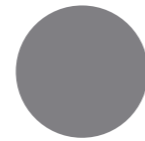

PMS Grey 10C



PMS 122C



PMS 166C

Map Colours



Interpon Anodic Silver Low Sheen

Feature Blade Colour

COLOURS

Coastal pathway brand

The 'boardwalk' mark and type is always to be PMS 122C Yellow on Dulux Woodland Grey.

Sign panel

Graphics to be White on PMS 315c background. When using vinyl White to be specified as Avery White Matt.



MAP STANDARDS

Site arrival map

Maps on signs should be orientated to suit the direction the viewer is facing. This map is made up of two elements:

- (i) You Are Here Map
- (ii) Contextual Map with Legend and Logo

Both elements are to be used together when developing maps for the Site Arrival signs.

This map is pedestrian focused and is to encompass the geographic area of the key urban precinct within the town or city. The following is to be shown:

- You are Here locator
- Coastal Pathway
- parks and greenspace along the pathway
- beach areas along with elements of the ocean
- lakes, rivers and creeks
- primary networks roads and secondary streets and lanes
- all Council facilities and assets with pictograms
- transport hubs with pictograms and message

Site arrival map

Where a beach is patrolled by Surf Life Saving Queensland – The (PPB) pictogram should be located on the map above and left justified with the beach name.

Sunshine Coast Council logo

The Logo should be reproduced on maps only. When using the map for printed collateral such as brochures, then the logo is to be accompanied with the phone number and web site.

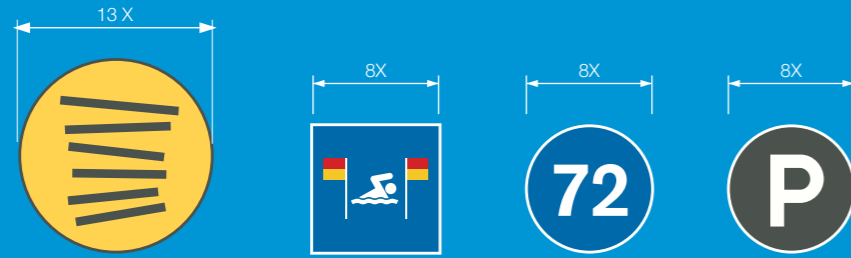

Dicky Beach 6.5X

Berthold Akzidenz Grotesk Medium

**Tooway
Creek** 4X

Berthold Akzidenz Grotesk Medium

WILLIAM ST 3X

Berthold Akzidenz Grotesk Regular

MAP STANDARDS

Site arrival map

Text and pictogram guides

Refer to adjacent diagram showing proportion and hierarchy details.

Typical overall sizes

The geographic shape and extent for each pathway Connection across the region will differ, therefore scales of map will also differ. The rule is to select the Connection with a small extent of the pathway to the north and south shown. This area is to be scaled to the height of allowed sign panel. This will provide consistent map scales across the region.

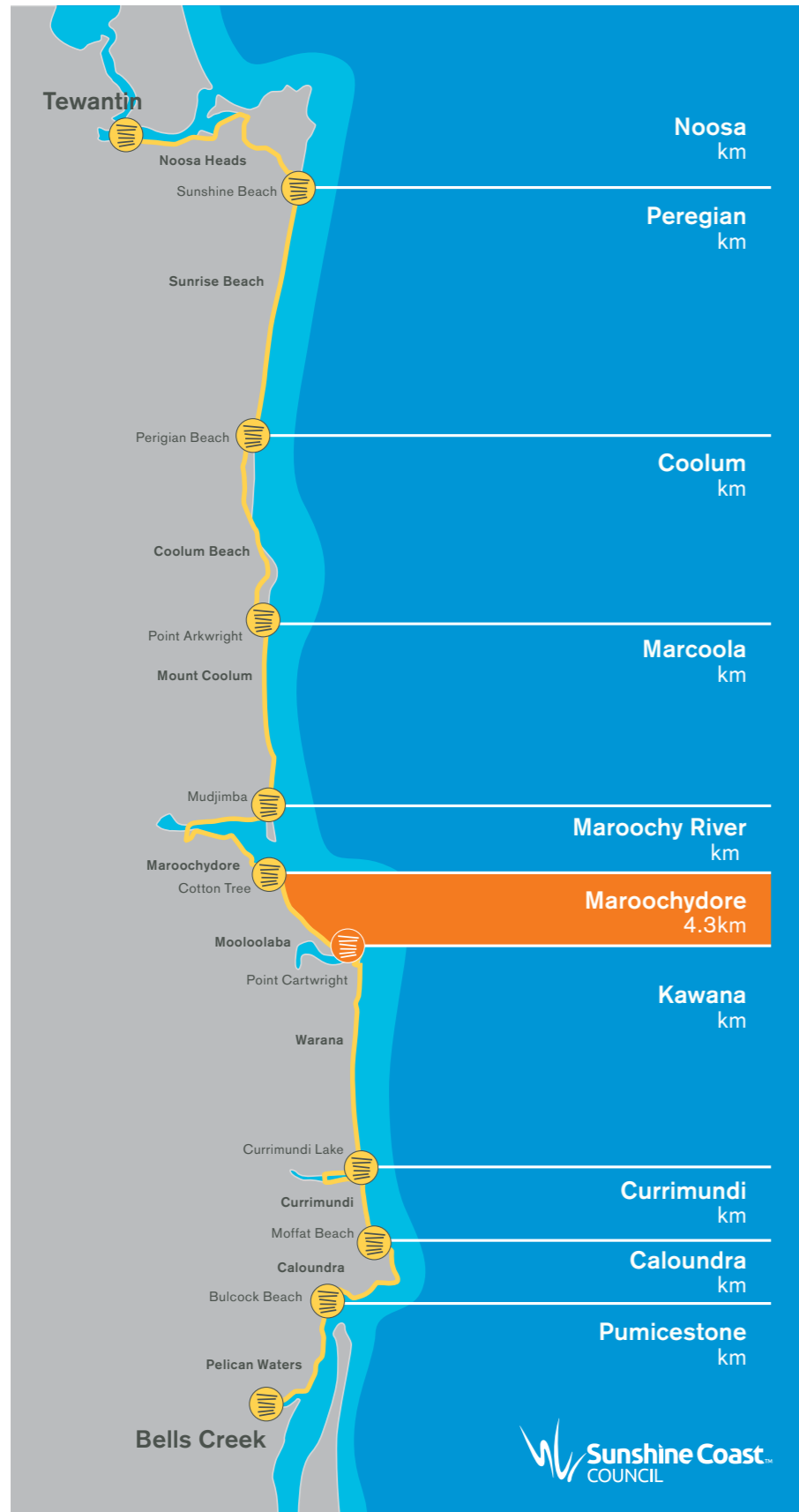

Connection distances are indicative only
Final distances to be confirmed

MAP STANDARDS

Connection map

These maps are to be used on the Tier 1 Connection Identification Signs.

Maps on signs should be orientated to suit the direction the viewer is facing. This map is to show the following:

- (i) Overall pathway from Tewantin to Bells Creek
- (ii) All ten Connections
- (ii) The connection you are entering

The trail head or point of sign location is to be shown as an orange marker with remaining trail heads in yellow.

Sunshine Coast Council logo

The Logo should be reproduced on maps only. When using the map for printed collateral such as brochures, then the logo is to be accompanied with the phone number and web site.

C

SIGN TYPES

Sign type summary

TIER 1 Wayfinding signs

- 1.1 Connection identification sign
- 1.2 Arrival information sign
- 1.3 Distance marker identification sign

TIER 2 Supplementary signs

- 2.1 On road marker sign
- 2.2 Directional sign
- 2.3 Warning information sign
- 2.4 Activity measurement sign
- 2.5 Directional finger blade
- 2.6 Directional bollard

TIER 3 Behavioural signs

- 3.1 Cross over graphics
- 3.2 Behavioural bollard

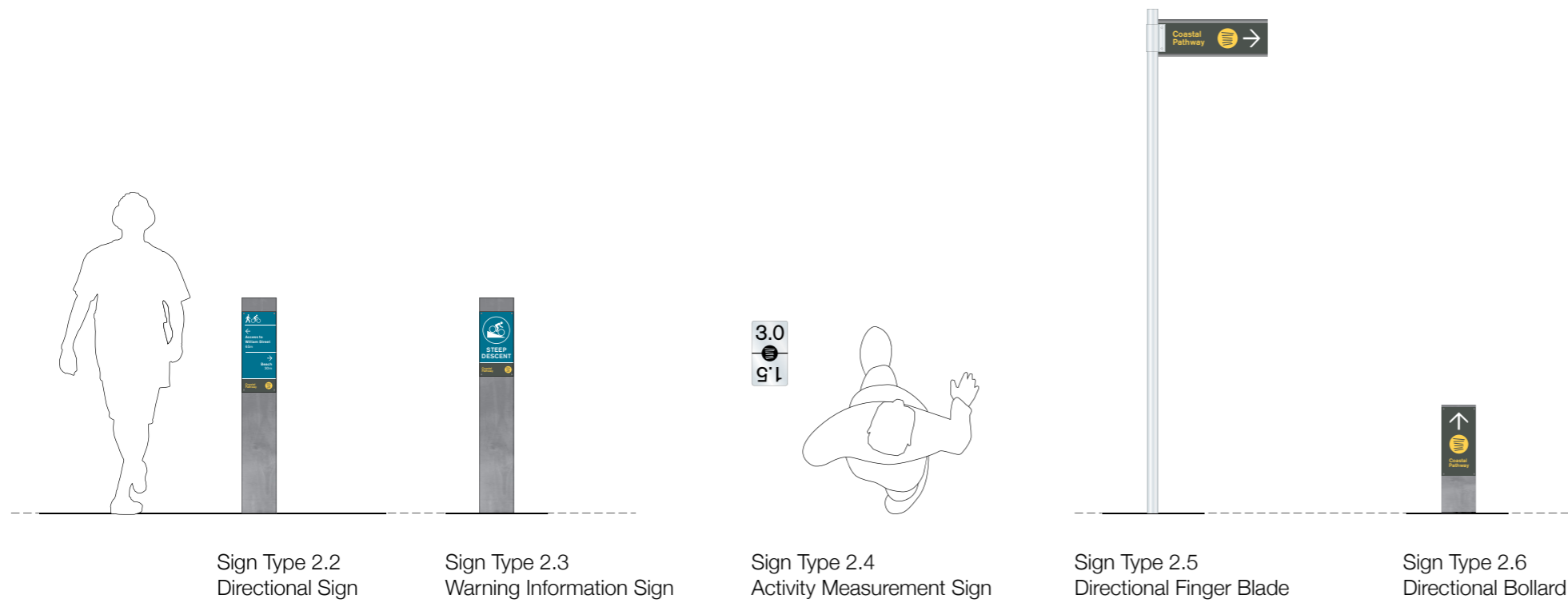
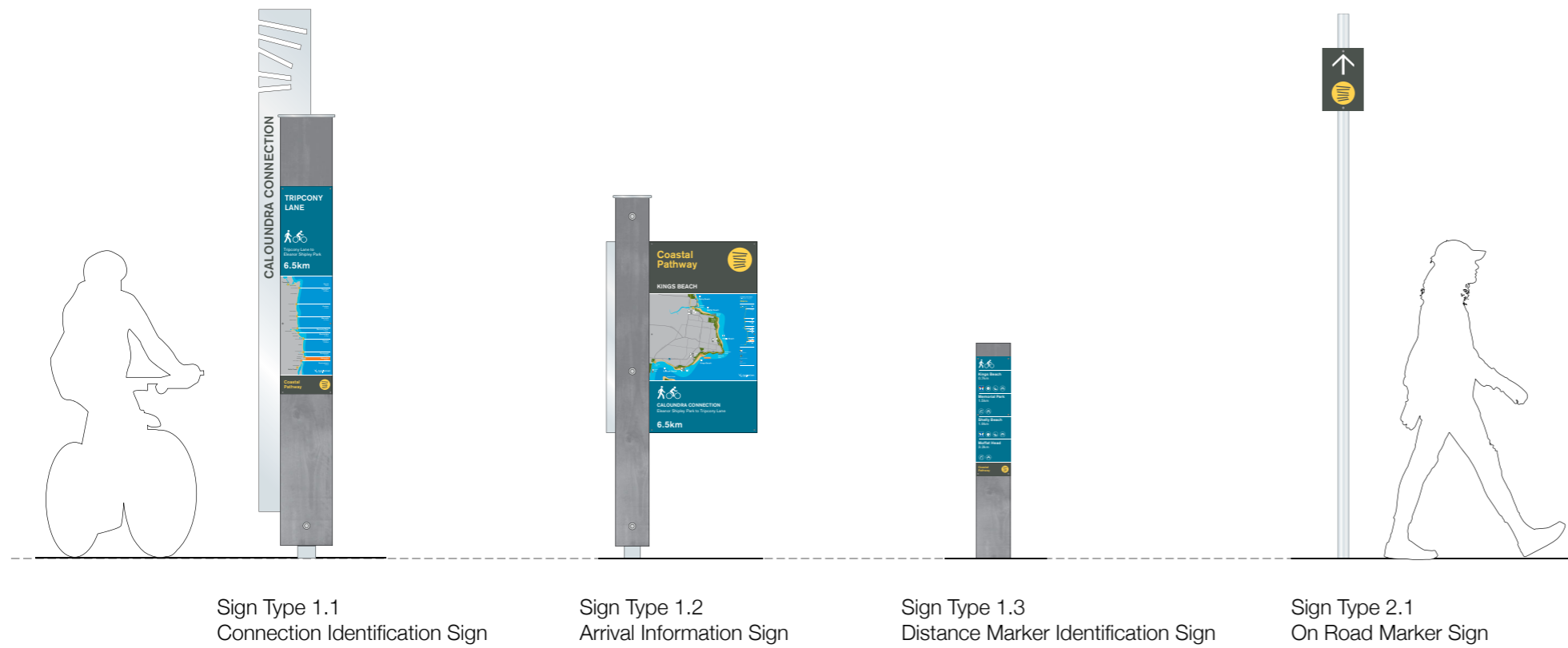

Sign type summary

TIER 1 Wayfinding signs
Sign type 1

TIER 2 Supplementary signs
Sign type 2

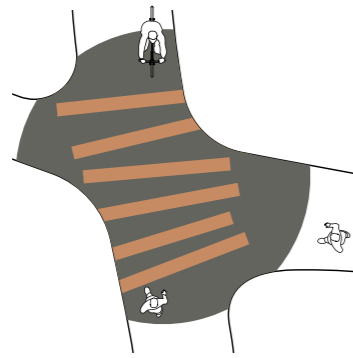

Angular Intersection

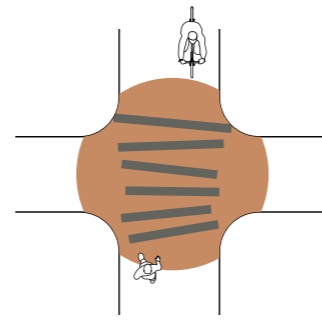

Cross Intersection

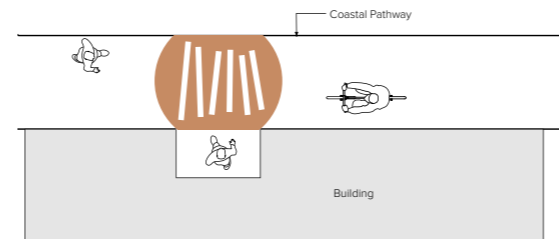

Building Exit

Sign Type 3.1
Cross Over Graphics



Sign Type 3.2
Behavioural Bollard - Pedestrian



Sign Type 3.2
Behavioural Bollard - Cyclist

Sign type summary

TIER 3 Behavioural signs
Sign type 3

TIER 1 WAYFINDING SIGNS

Sign type 1.1
Connection identification sign
 Sheet 1 of 3

Unless otherwise noted all dimensions in millimetres. Use figured dimensions in preference to scaling. Contractor to confirm all dimensions and details on site prior to manufacture.

Signmaker to confirm all details for approval on shop drawings prior to manufacture. All structural members, fixings and/or footings to be confirmed by sign maker's engineer.

Due to this reproduction process the colours in this image are not exact representations of the final product.

LOCATION PRINCIPLES

Connection identification signs are located at either end of each connection to act as a trail head providing start and end points. The signs also promote connectivity between each of the 10 connection zones.

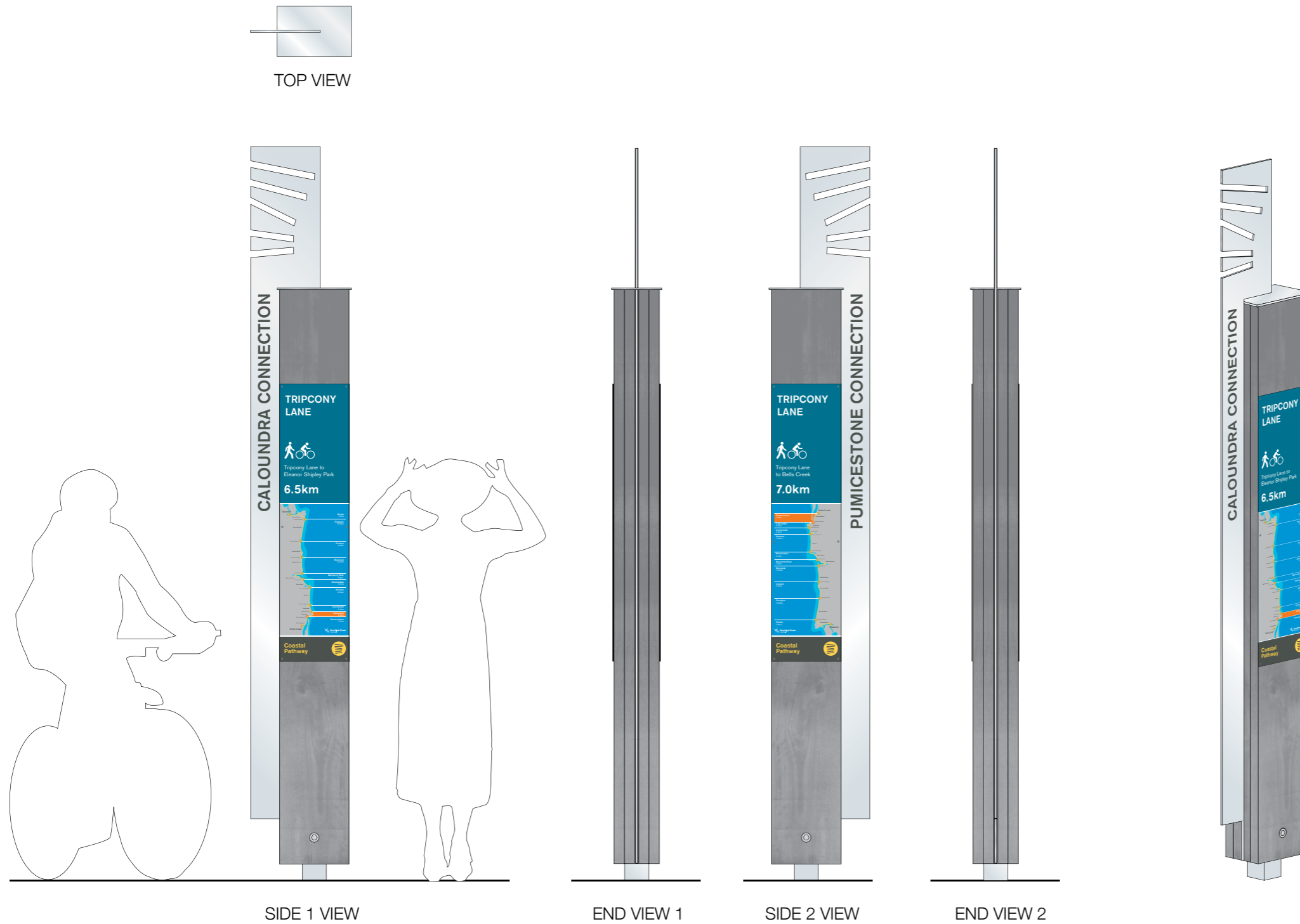

Typical Elevations
 Scale 1:20

TIER 1 WAYFINDING SIGNS

Sign type 1.1
Connection identification sign
Sheet 2 of 3

Unless otherwise noted all dimensions in millimetres. Use figured dimensions in preference to scaling. Contractor to confirm all dimensions and details on site prior to manufacture.

Signmaker to confirm all details for approval on shop drawings prior to manufacture. All structural members, fixings and/or footings to be confirmed by sign maker's engineer.

Due to this reproduction process the colours in this image are not exact representations of the final product.

GRAPHIC LAYOUT DETAILS

FULL COLOUR DIGITAL PRINT
290 x 1160 full colour digital print (including Header, Map and Footer panels) onto polymetric vinyl with anti graffiti polyvinyl fluoride film over.

Font

Connection Name = Akzidenz Grotesk Medium
Connection Terminus = Akzidenz Grotesk Regular
Distance = Akzidenz Grotesk Medium

Colour

HEADER PANEL
Background = PMS 315C
Graphics = Avery White Matt 920
Shared path pictograms = Avery White Matt 920

MAP PANEL

Full colour digital print onto polymetric vinyl, refer to Section B - Graphic Standards for map colours.

FOOTER PANEL

Background = Colorbond Woodland Grey
Coastal Pathway = PMS 122C

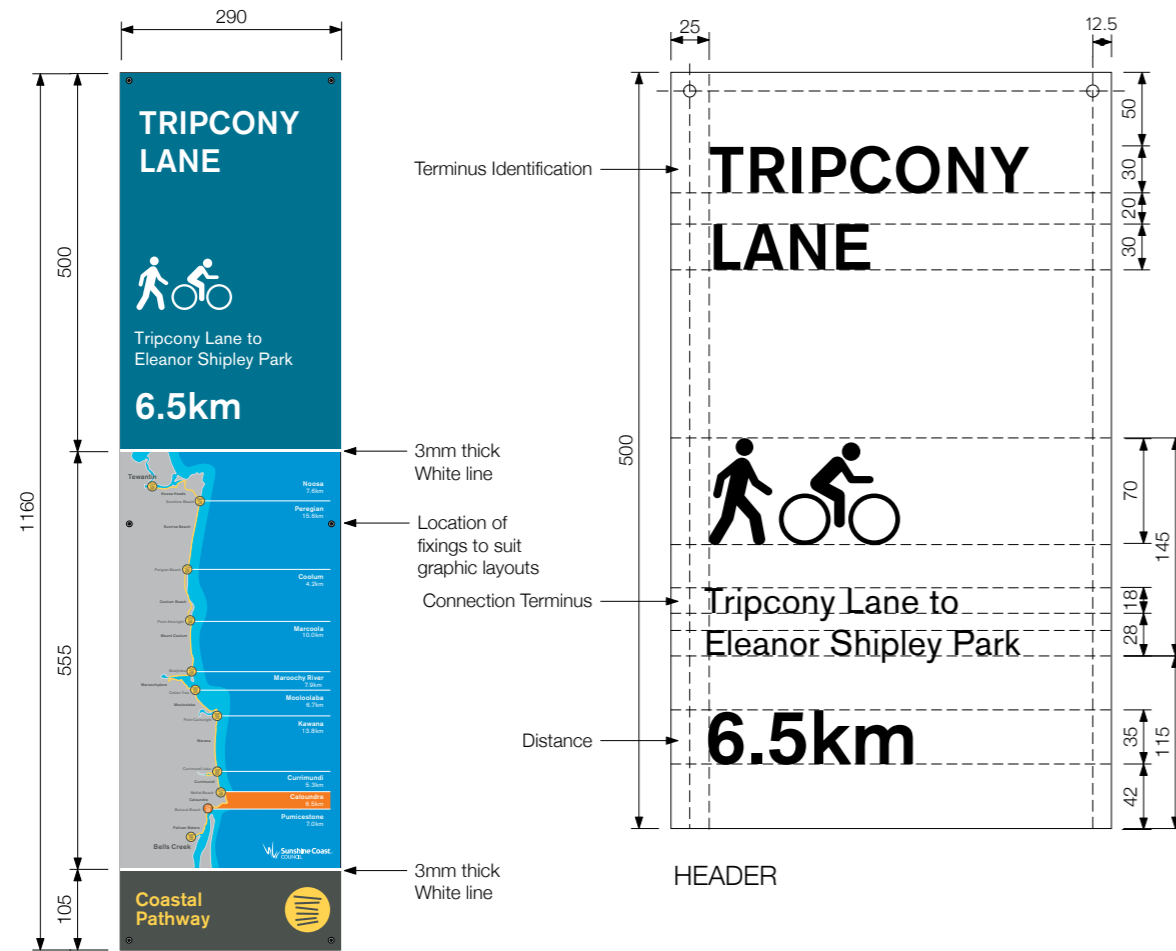

SIGN PANEL

Typical Layout
Scale 1:10

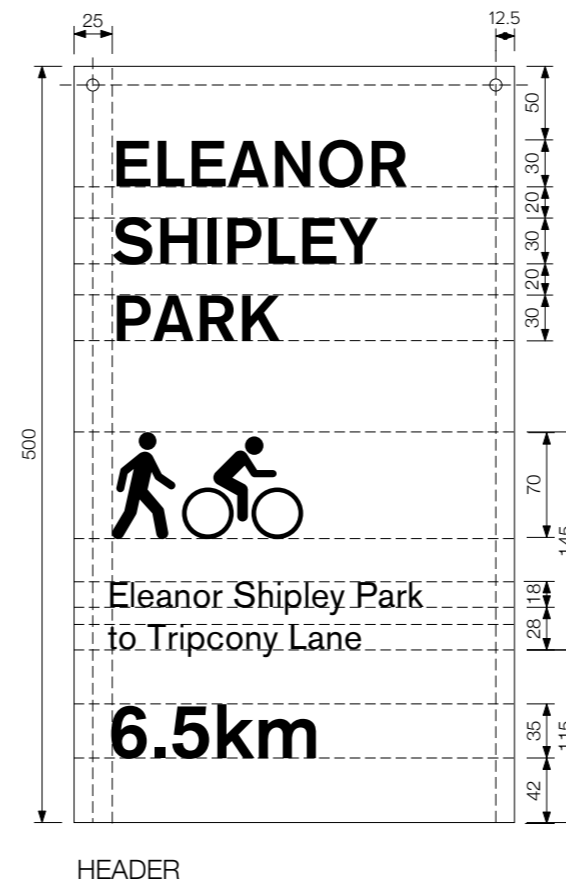

HEADER

HEADER

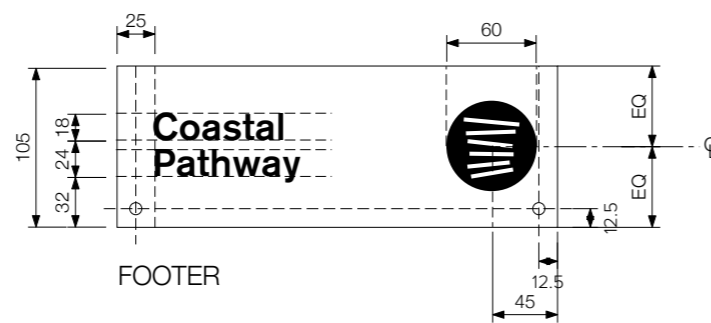

Typical Graphic Detail
Scale 1:5

TIER 1 WAYFINDING SIGNS

Sign type 1.1
Connection identification sign
Sheet 3 of 3

Unless otherwise noted all dimensions in millimetres. Use figured dimensions in preference to scaling. Contractor to confirm all dimensions and details on site prior to manufacture.

Signmaker to confirm all details for approval on shop drawings prior to manufacture. All structural members, fixings and/or footings to be confirmed by sign maker's engineer.

Due to this reproduction process the colours in this image are not exact representations of the final product.

CONSTRUCTION DETAILS

1. 10mm thick aluminium sign panel laser cut and welded to internal structural post. To be primed and powder coated Interpon Anodic Silver Low Sheen
2. 310 x 210 x 6mm aluminium top cap with slot for blade welded in place
3. 10mm thick aluminium blade welded to internal structural post. To be primed and powder coated Interpon Anodic Silver Low Sheen
4. 100 x 100 x 6mm SHS structural post
5. 290 x 44mm hardwood timber with two 90 x 35mm hardwood timber panels fixed directly to the inside face of the timber panel. Faces and sides to be standard sizes screwed together to form channel, mounted to both sides of internal structural post. Timber is to be F27 Kiln Dried Hardwood Class 1 Durability rating - Queensland Spotted Gum or Queensland Iron Bark or similar if unavailable. Tanalith E / ACQ Treatment, CN oil finish top coat and treated with Tanacoat oil.
6. Artwork on separate 3mm panel, mounted directly to timber with torx screws
7. M20 stainless steel nuts sit flush to timber face, concealed by graphic panel
8. Countersunk stainless steel M20 dome nuts on visible mounting points
9. Spring washer to reduce impact of timber shrinkage
10. Front and rear timber panels fixed with M20 stainless steel bolts at three points

FOOTINGS

Reinforced concrete footing to be confirmed by sign maker's engineer. All fixings shall be below ground level to reduce trip hazards. Re-instate / make good paving or pavement, with no changes of level greater than 3mm and no gradients steeper than 1:40

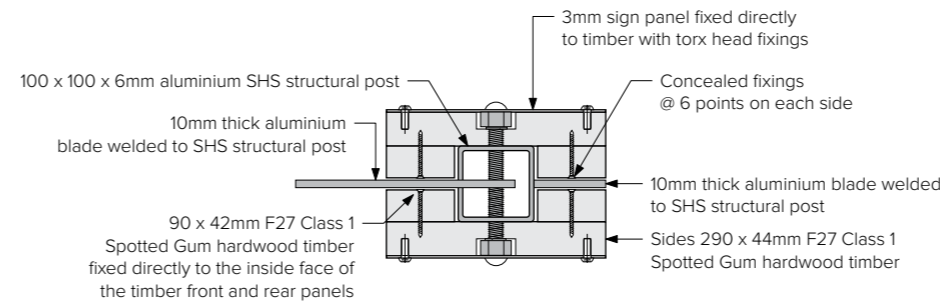

Section A - A
Scale 1:10

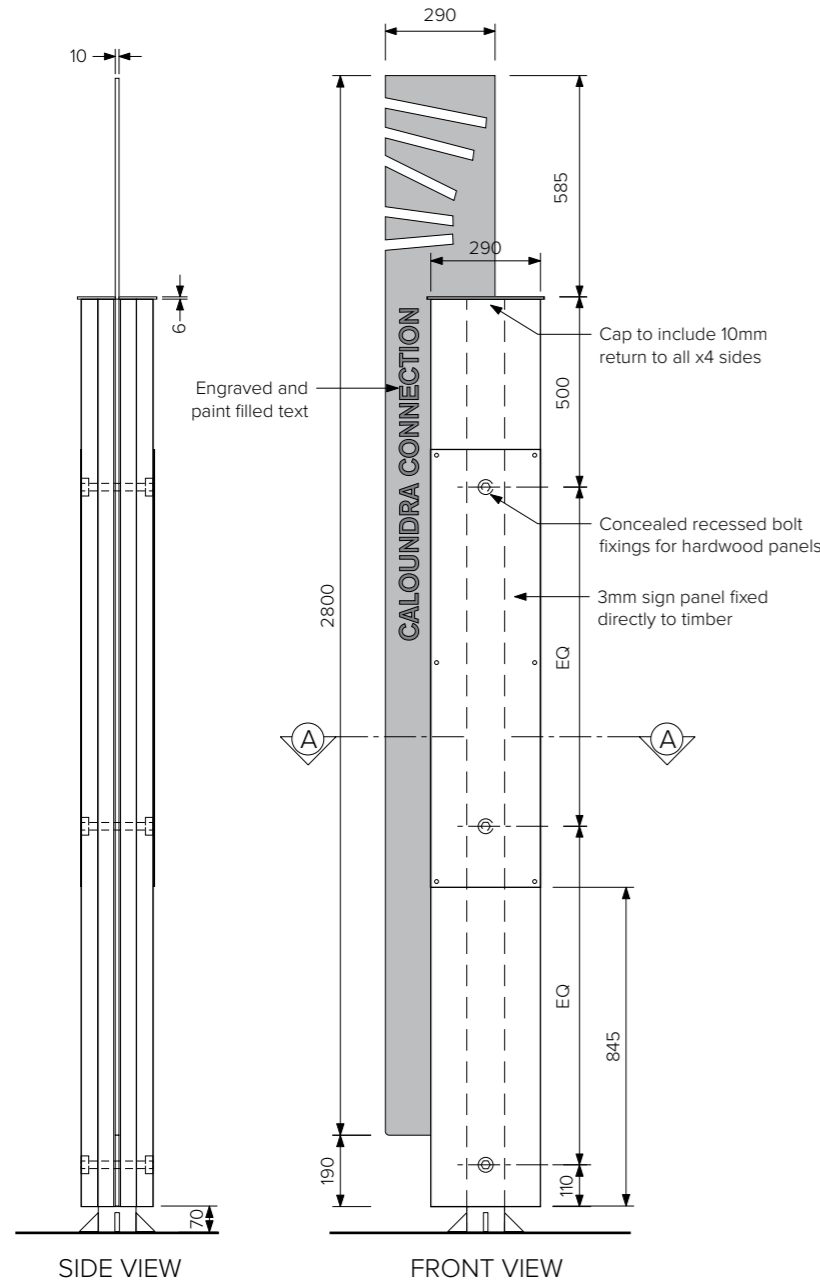

Typical Elevations
Scale 1:20

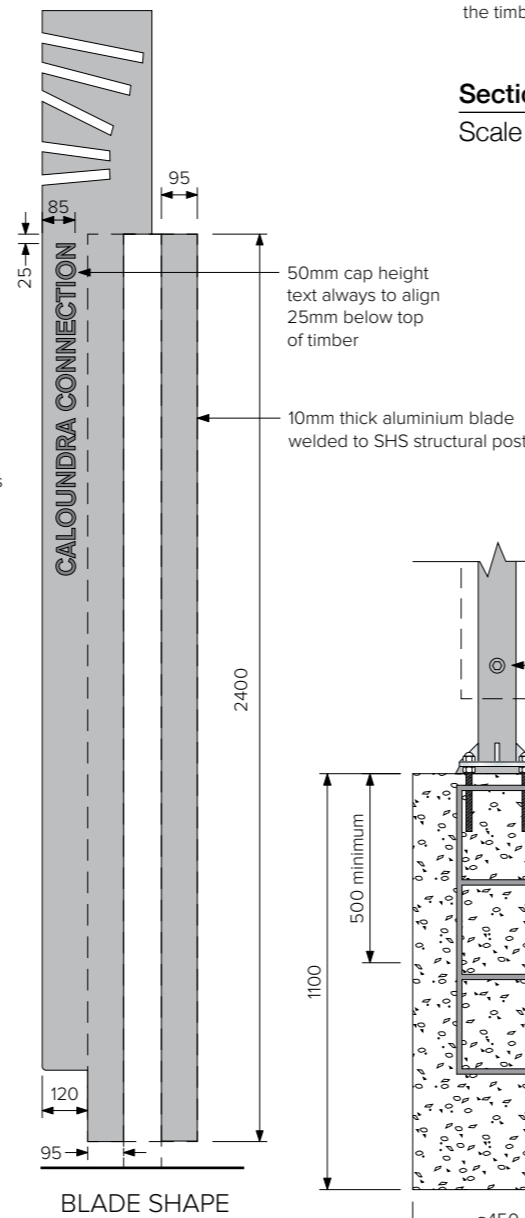

Footing Detail
Scale 1:20

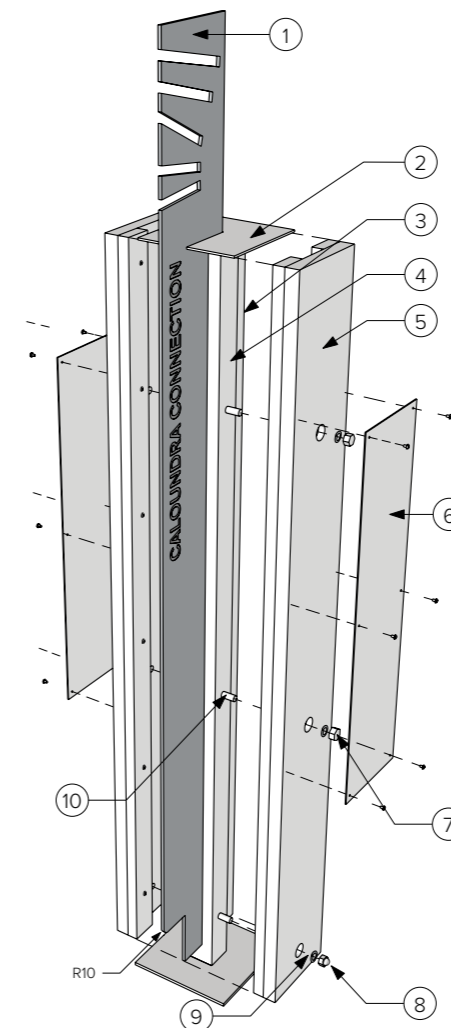

Exploded view of assembly
Not to scale

TIER 1 WAYFINDING SIGNS

**Sign type 1.2
Arrival information sign
Sheet 1 of 3**

Unless otherwise noted all dimensions in millimetres. Use figured dimensions in preference to scaling. Contractor to confirm all dimensions and details on site prior to manufacture.

Signmaker to confirm all details for approval on shop drawings prior to manufacture. All structural members, fixings and/or footings to be confirmed by sign maker's engineer.

Due to this reproduction process the colours in this image are not exact representations of the final product.

LOCATION PRINCIPLES

Information arrival signs are located at main gathering nodes along the pathway. These nodes are typically located at prominent landmarks and destinations. The majority of users will typically enter the pathway at these locations. The users will then proceed north or south from these points.



TOP VIEW

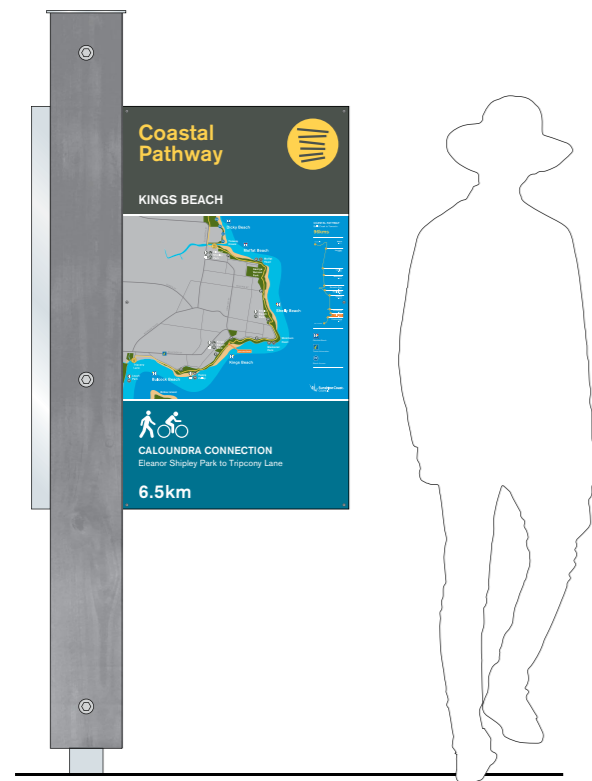

SIDE 1 VIEW

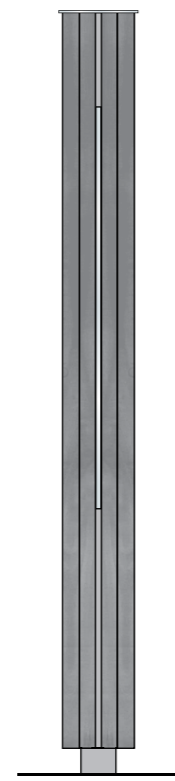

END VIEW 1



SIDE 2 VIEW

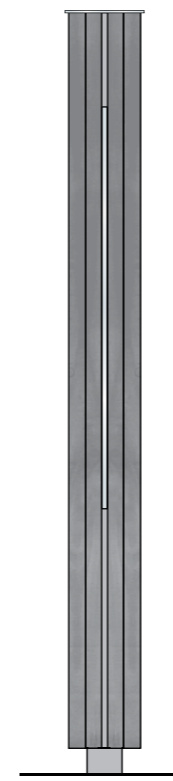

END VIEW 2

Typical Elevations

Scale 1:20

TIER 1 WAYFINDING SIGNS

Sign type 1.2
Arrival information sign
Sheet 2 of 3

Unless otherwise noted all dimensions in millimetres. Use figured dimensions in preference to scaling. Contractor to confirm all dimensions and details on site prior to manufacture.

Signmaker to confirm all details for approval on shop drawings prior to manufacture. All structural members, fixings and/or footings to be confirmed by sign maker's engineer.

Due to this reproduction process the colours in this image are not exact representations of the final product.

GRAPHIC LAYOUT DETAILS

FULL COLOUR DIGITAL PRINT
600 x 1065mm full colour digital print (including Header, Map and Footer panels) onto polymetric vinyl with anti graffiti polyvinyl fluoride film over

Font

Local Area Identification = Akzidenz Grotesk Medium
Connection Name = Akzidenz Grotesk Medium
Connection Terminus = Akzidenz Grotesk Regular
Distance = Akzidenz Grotesk Medium

Colour

HEADER PANEL
Background = Colorbond Woodland Grey
Coastal Pathway = PMS 122C

MAP PANEL

Full colour digital print onto polymetric vinyl, refer to Section B - Graphic Standards for map colours.

FOOTER PANEL

Background = PMS 315C
Graphics = Avery White Matt 920
Shared path pictograms = Avery White Matt 920



SIGN PANEL

Graphic Layout
Scale 1:10

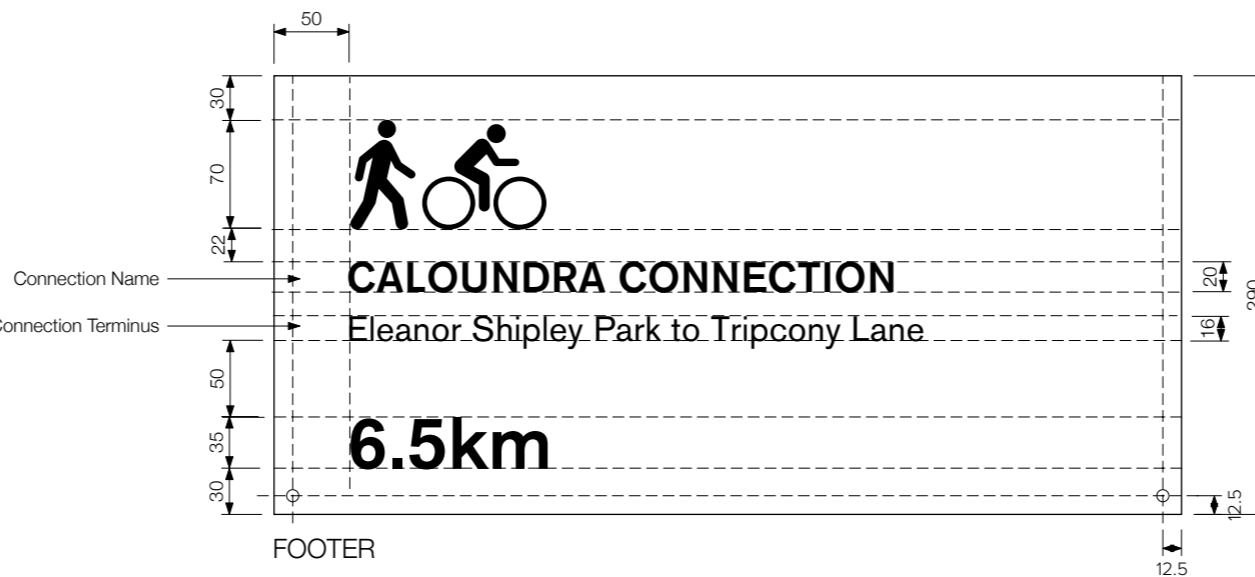
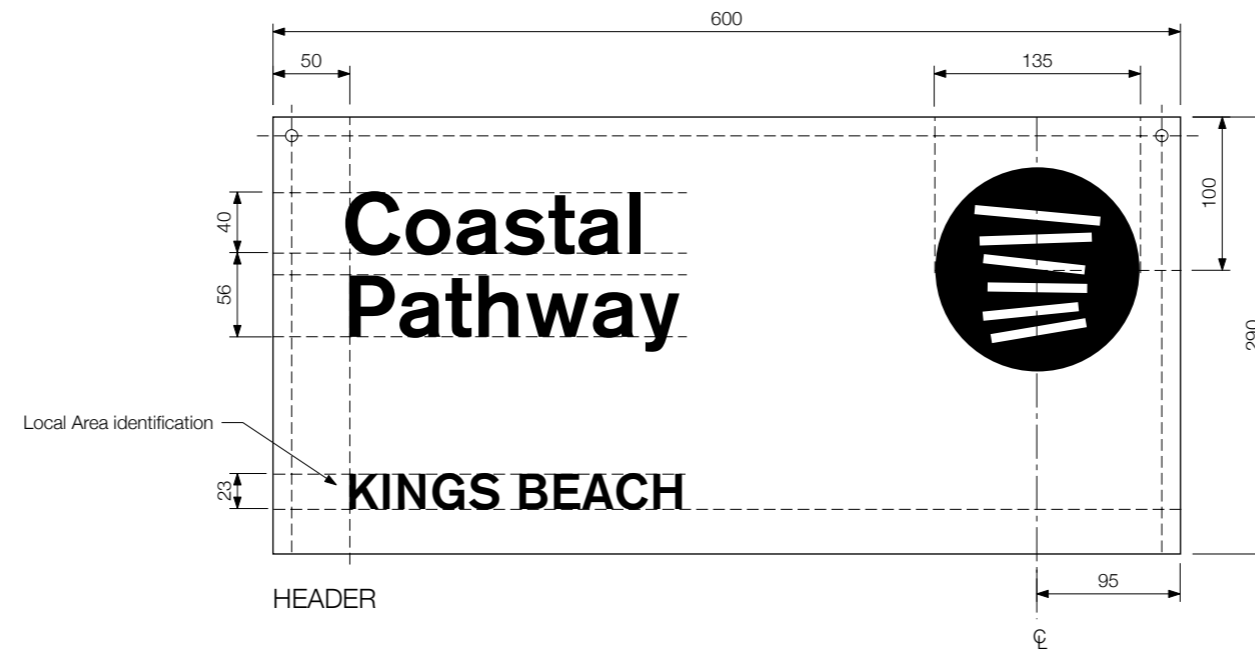

Graphic Detail
Scale 1:5

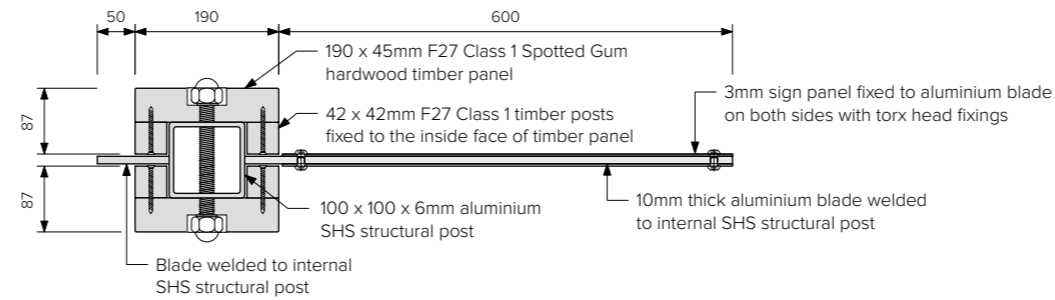
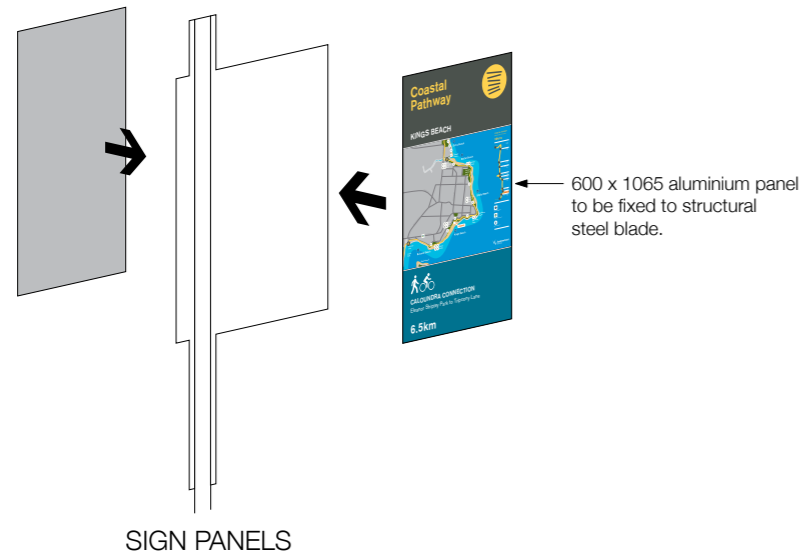

Section A - A
Scale 1:10

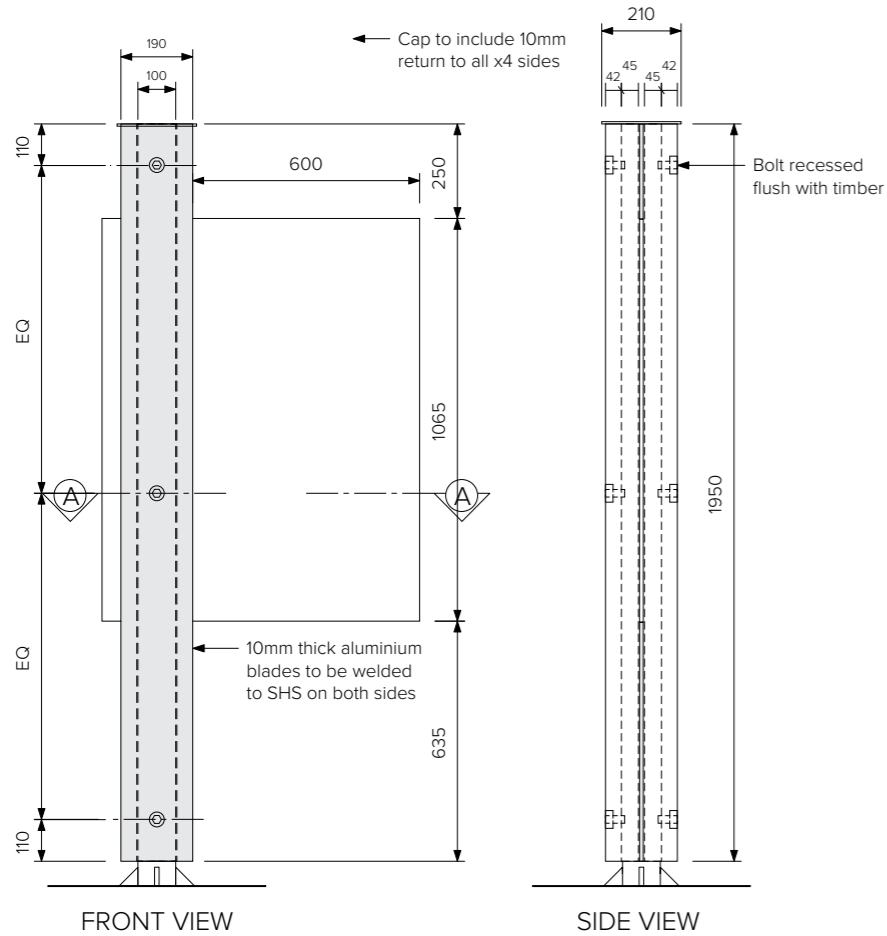

Typical Elevations
Scale 1:20

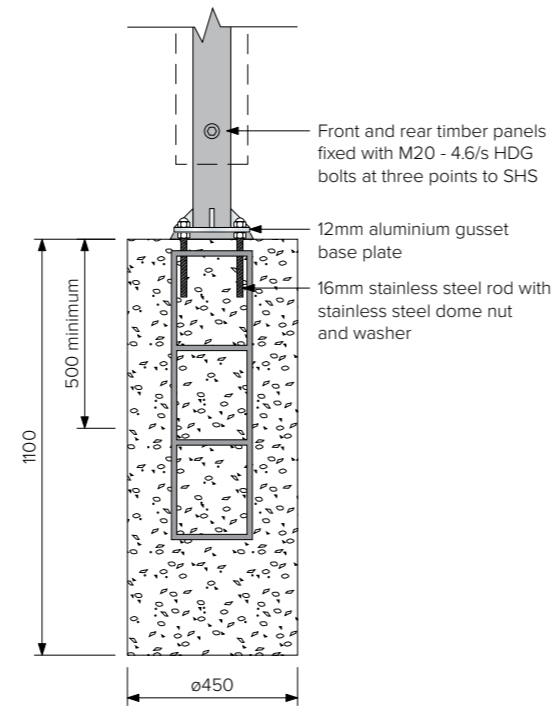

Footing Detail
Scale 1:20

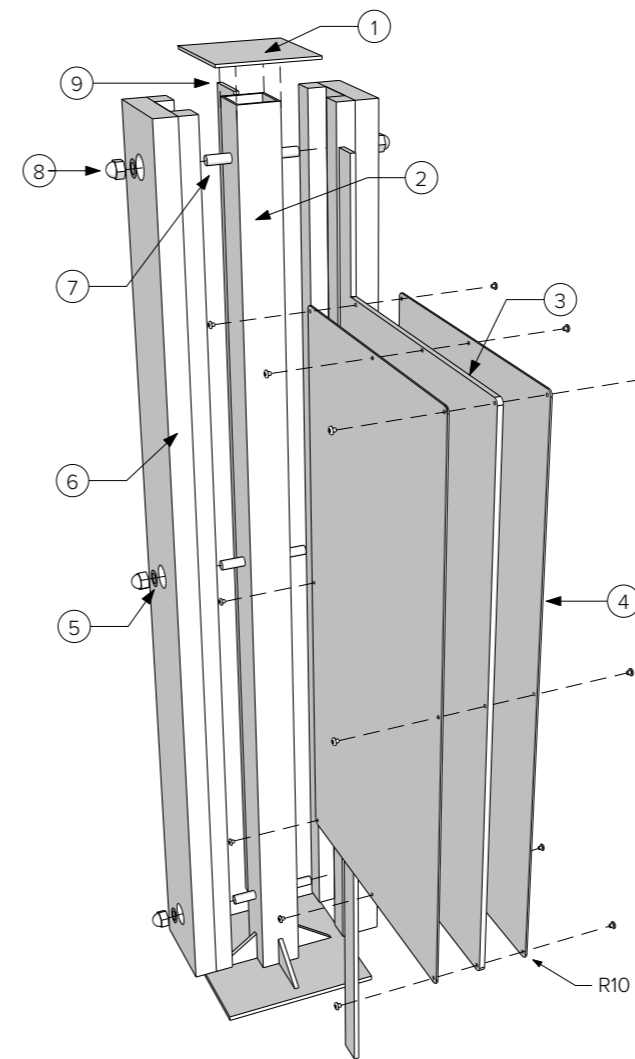

Exploded view of assembly
Not to scale

TIER 1 WAYFINDING SIGNS

Sign type 1.2
Arrival information sign
Sheet 3 of 3

Unless otherwise noted all dimensions in millimetres. Use figured dimensions in preference to scaling. Contractor to confirm all dimensions and details on site prior to manufacture.

Signmaker to confirm all details for approval on shop drawings prior to manufacture. All structural members, fixings and/or footings to be confirmed by sign maker's engineer.

Due to this reproduction process the colours in this image are not exact representations of the final product.

CONSTRUCTION DETAILS

- 210 x 210 x 6mm aluminium top cap welded to SHS support, to be primed and powder coated Interpon Anodic Silver Low Sheen
- 100 x 100 x 6mm SHS structural post
- 10mm thick aluminium sign panel welded to internal structural post. To be primed and powder coated Interpon Anodic Silver Low Sheen
- Artwork on separate 600 x 1065 x 3mm panel, mounted to sign blade with torx screws
- Spring washer to reduce impact of timber shrinkage
- 190 x 45mm hardwood timber panel with two 42 x 42mm hardwood timber posts fixed to the inside face of timber panel. Faces and sides to be standard sizes screwed together to form channel, mounted to both sides of internal structural post. Timber is to be F27 Kiln Dried Hardwood Class 1 Durability rating - Queensland Spotted Gum or Queensland Iron Bark or similar if unavailable. Tanalith E / ACQ Treatment, CN oil finish top coat and treated with Tanacoat oil.
- Front and rear timber panels fixed with M20 stainless steel bolts at three points
- Countersunk stainless steel M20 dome nuts fix timber outer to SHS structural post
- 10mm thick aluminium blade welded to internal SHS structural post, to be primed and powder coated Interpon Anodic Silver Low Sheen

FOOTINGS

Reinforced concrete footing to be confirmed by sign maker's engineer. All fixings shall be below ground level to reduce trip hazards. Re-instate / make good paving or pavement, with no changes of level greater than 3mm and no gradients steeper than 1:40

TIER 1 WAYFINDING SIGNS

Sign type 1.3
Distance marker identification sign
Sheet 1 of 2

Unless otherwise noted all dimensions in millimetres. Use figured dimensions in preference to scaling. Contractor to confirm all dimensions and details on site prior to manufacture.

Signmaker to confirm all details for approval on shop drawings prior to manufacture. All structural members, fixings and/or footings to be confirmed by sign maker's engineer.

Due to this reproduction process the colours in this image are not exact representations of the final product.

LOCATION PRINCIPLES

Distance identification signs are located along the pathway between key arrival nodes – secondary landmarks, major intersections or places of interest. These are points where new users may enter the pathway. These signs provide connections to the arrival nodes.

CONSTRUCTION DETAILS

TIMBER BOLLARD

Timber is to be F27 Kiln Dried Hardwood Class 1 Durability rating - Queensland Spotted Gum or Queensland Iron Bark or similar if unavailable. Dressed/machined timber to specified size. Tanalith E / ACQ Treatment, CN oil finish top coat and treated with Tanacoat oil.

SIGN PANELS

2mm thick fabricated aluminium sign panel fixed flush to face of timber column. Full colour digital print on polymeric vinyl with anti graffiti polyvinyl fluoride film over.

FOOTINGS

Reinforced no-fines concrete pad/pier footing to signmakers' engineer specification. All fixings shall be below ground level to reduce trip hazards. Re-instate / make good paving or pavement, with no changes of level and no gradients steeper than 1:40.

ALTERNATIVE BOLLARD OPTION

RECYCLED PLASTIC BOLLARD

Bollard = 'The Marion' by Replas Recycled Plastic Products
Size = 200mm wide x 75mm thick
Colour = Replas Grey

Refer www.replas.com.au

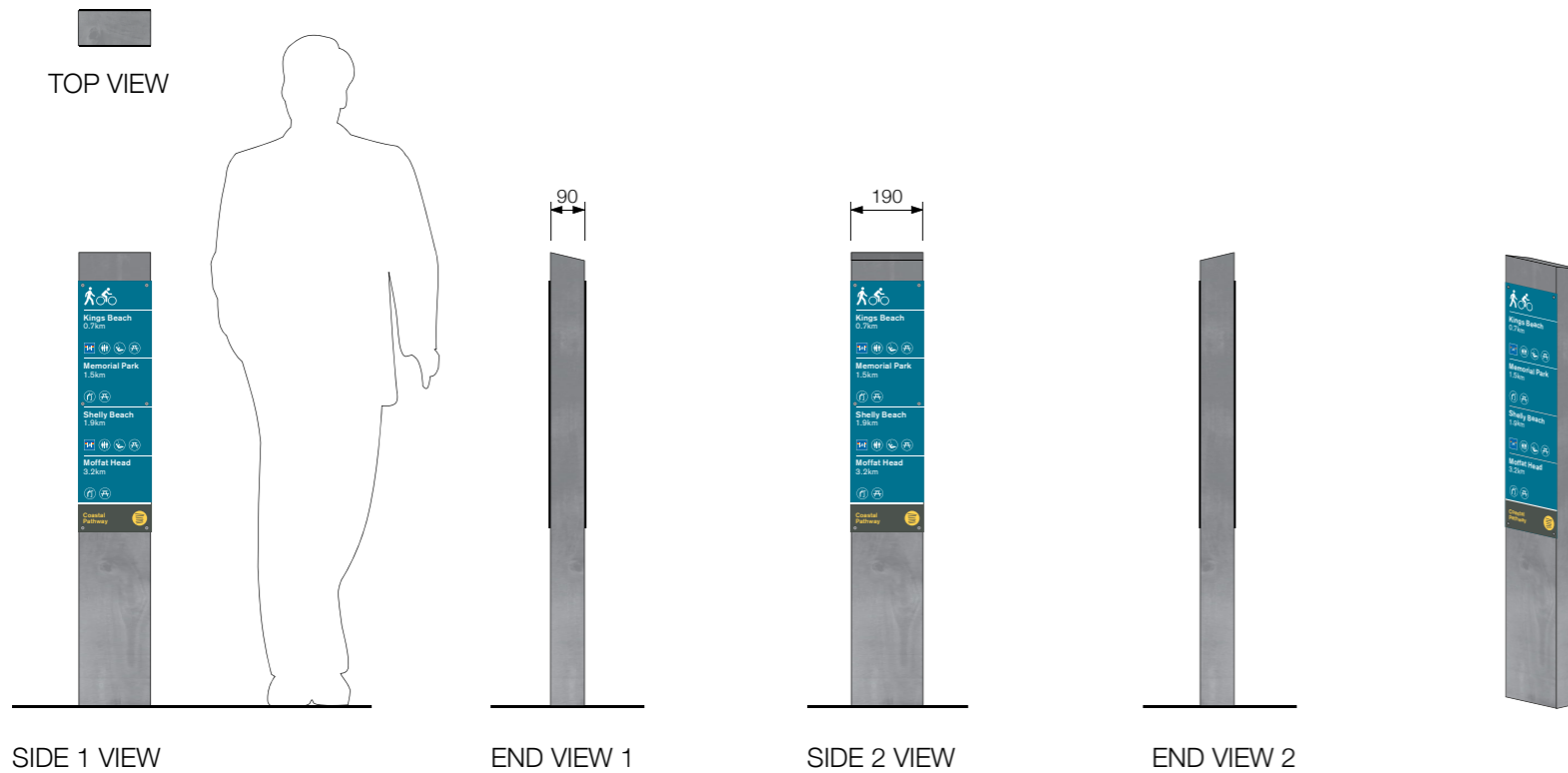

Typical Elevations

Scale 1:20

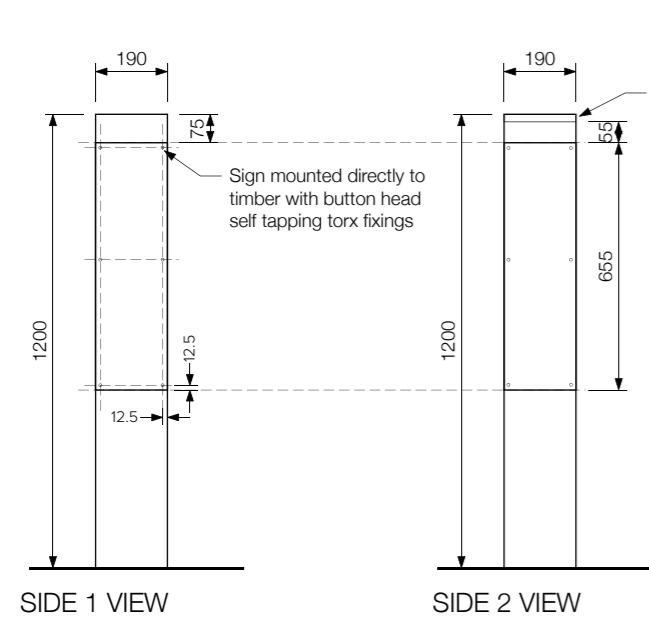

Dimensions

Scale 1:20

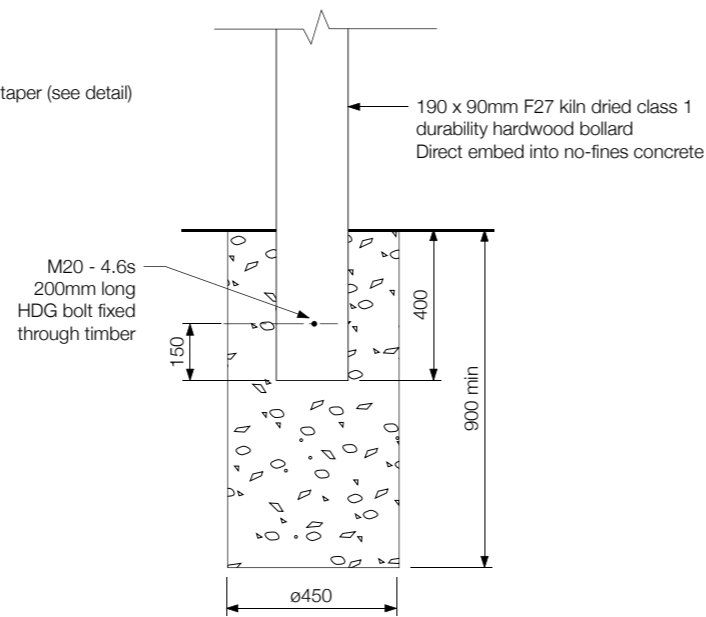

Direct Embed Footing Detail

Scale 1:20

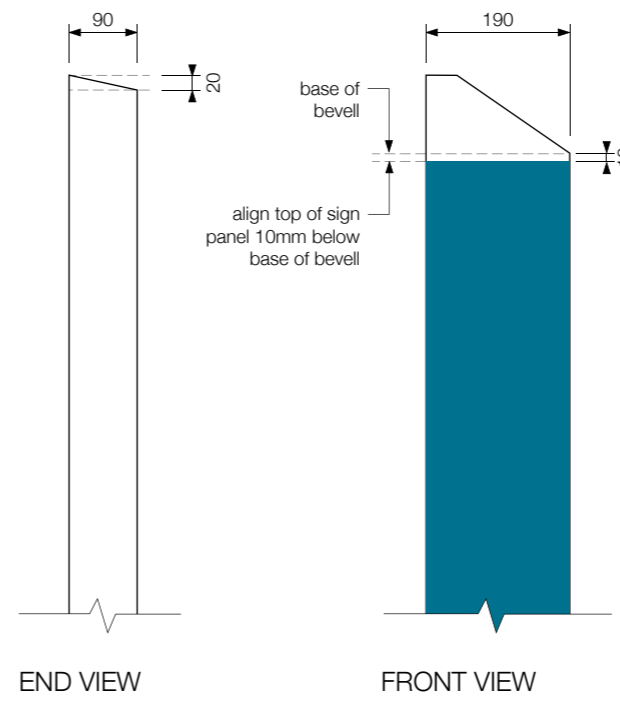

Tapered Detail

Recycled Plastic Detail

Scale 1:10

Recycled Plastic Detail

Recycled Plastic Detail

Scale 1:10

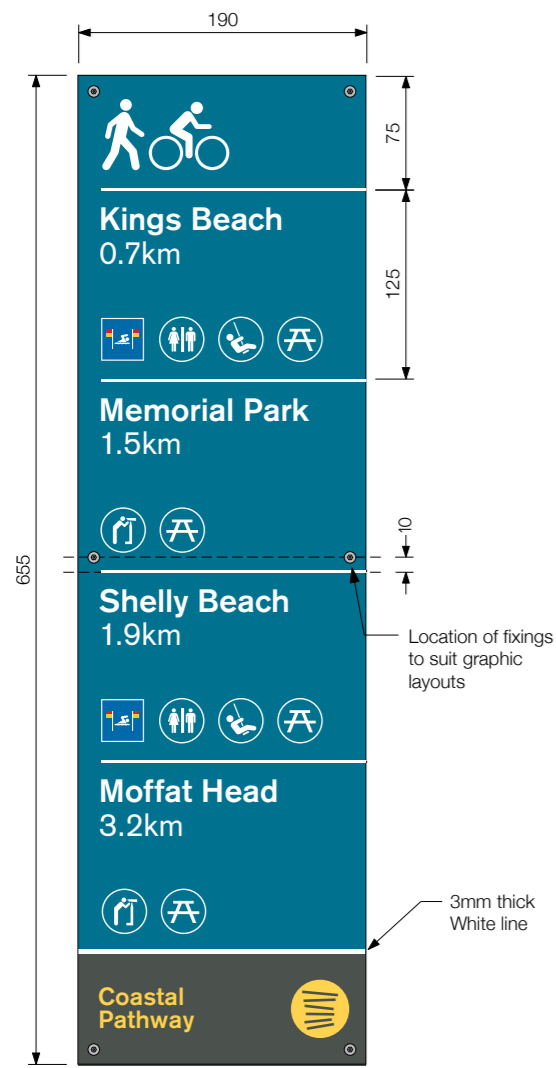

SIGN PANEL

Typical Graphic Layout
Scale 1:5

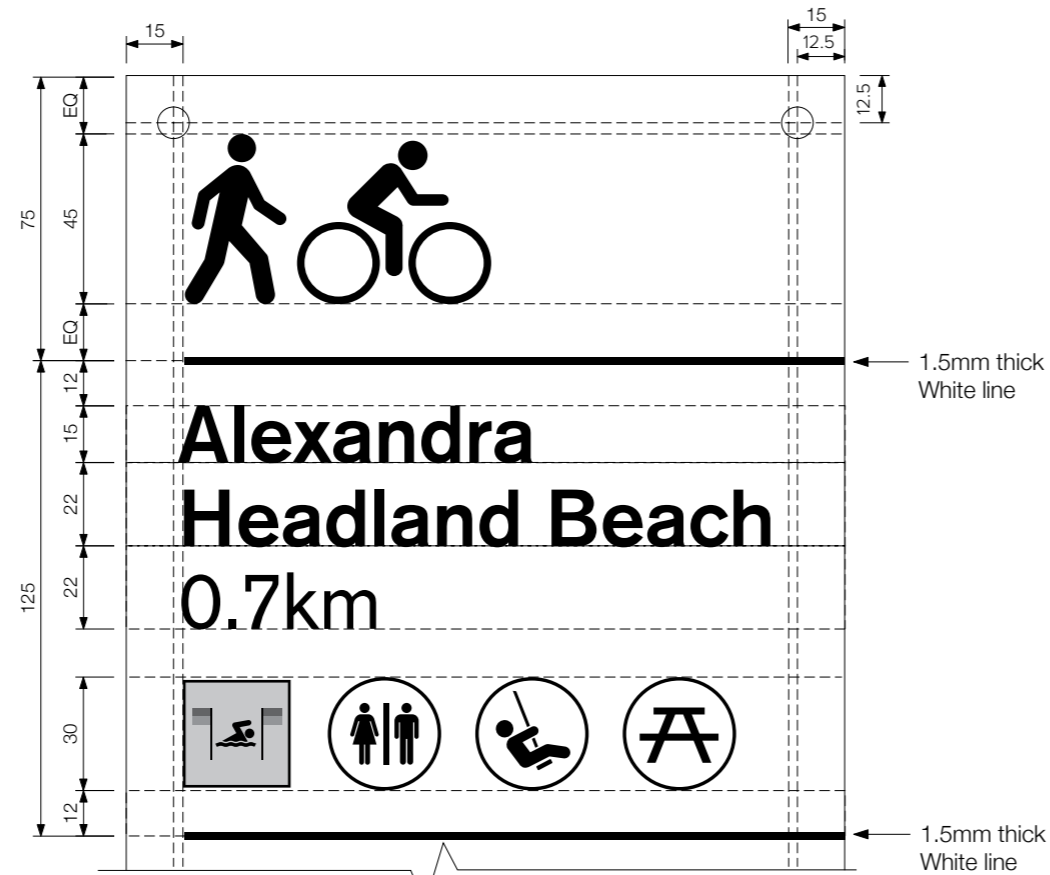

SIGN PANEL DETAIL

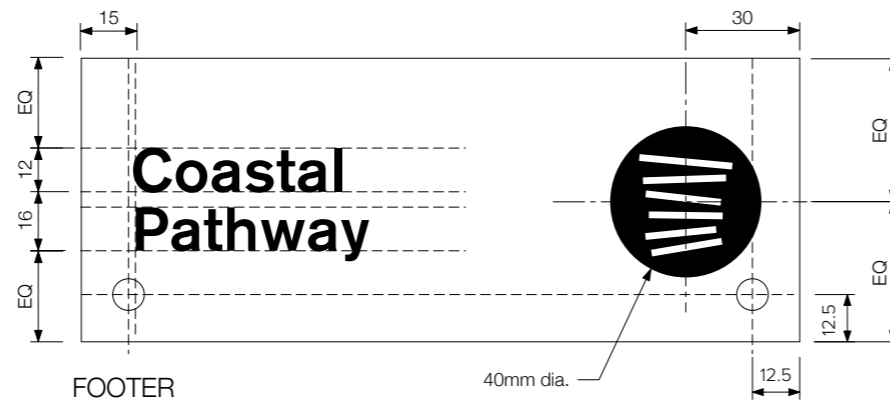

FOOTER

Graphic Layout
Scale 1:2

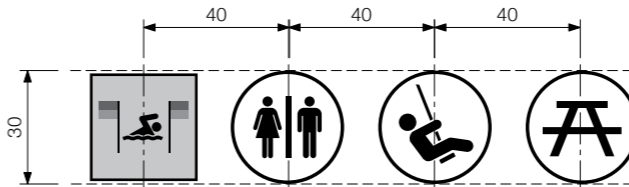

PICTOGRAM SET OUT

Graphic Layout
Scale 1:2

TIER 1 WAYFINDING SIGNS

Sign type 1.3
Distance marker identification sign
Sheet 2 of 2

Unless otherwise noted all dimensions in millimetres. Use figured dimensions in preference to scaling. Contractor to confirm all dimensions and details on site prior to manufacture.

Signmaker to confirm all details for approval on shop drawings prior to manufacture. All structural members, fixings and/or footings to be confirmed by sign maker's engineer.

Due to this reproduction process the colours in this image are not exact representations of the final product.

GRAPHIC LAYOUT DETAILS

FULL COLOUR DIGITAL PRINT
190 x 655mm full colour digital print (including Sign and Footer panels) onto polymetric vinyl with anti graffiti polyvinyl fluoride film over.

Font

Destination = Akzidenz Grotesk Medium
Distance = Akzidenz Grotesk Regular

Colour

SIGN PANEL
Background = PMS 315C
Graphics = Avery White Matt 920
Shared path pictograms = Avery White Matt 920

FOOTER PANEL

Background = Colorbond Woodland Grey
Coastal Pathway = PMS 122C

TIER 2 SUPPLEMENTARY SIGNS

**Sign type 2.1
On road marker sign
Sheet 1 of 1**

Unless otherwise noted all dimensions in millimetres. Use figured dimensions in preference to scaling. Contractor to confirm all dimensions and details on site prior to manufacture.

Signmaker to confirm all details for approval on shop drawings prior to manufacture. All structural members, fixings and/or footings to be confirmed by sign maker's engineer.

Due to this reproduction process the colours in this image are not exact representations of the final product.

LOCATION PRINCIPLES

Located on the main road network to direct and identify the continuation of the pathway. To be used in conjunction with existing traffic/street sign structures.

CONSTRUCTION DETAILS

SIGN PANELS

2mm aluminium with full colour digital print onto polymeric vinyl with anti graffiti polyvinyl fluoride film over.

FIXING

Panel to be fixed to sign post as required.

GRAPHIC LAYOUT DETAILS

FULL COLOUR DIGITAL PRINT

230 x 350mm full colour digital print onto polymeric vinyl with anti graffiti polyvinyl fluoride film over.

Colour

SIGN PANEL

Background = Colorbond Woodland Grey
Coastal Pathway = PMS 122C

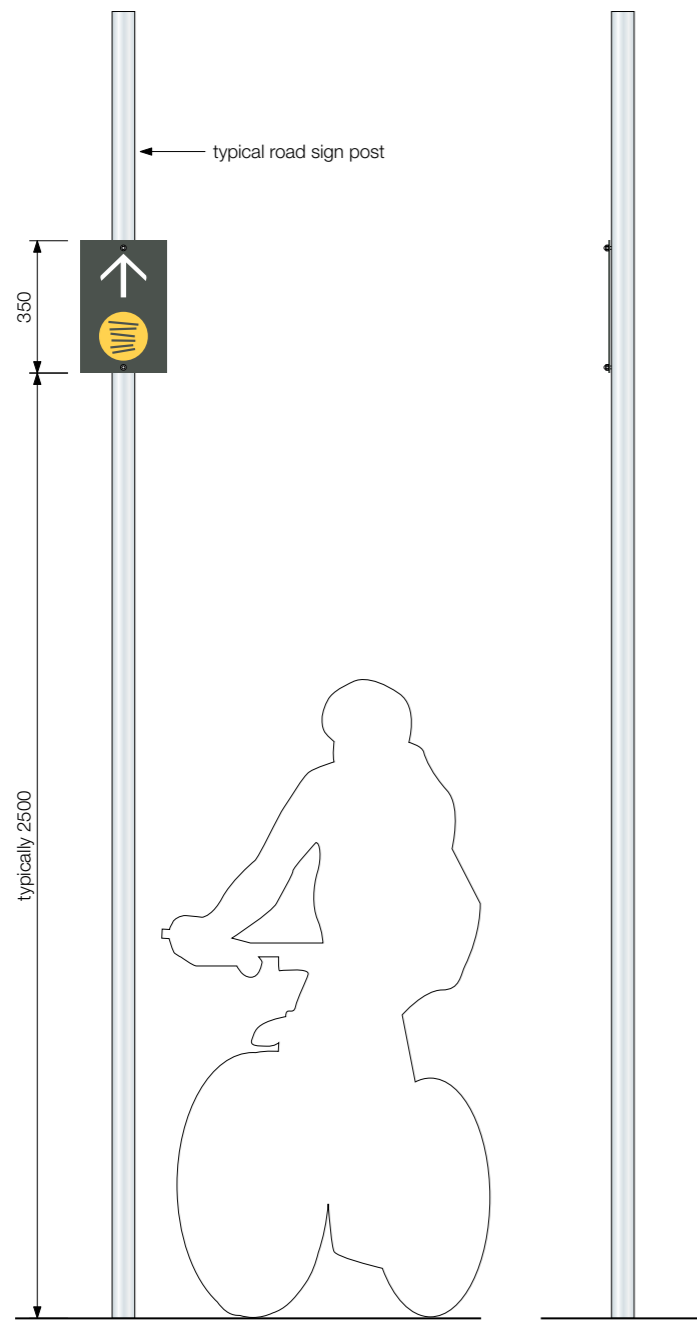

FRONT VIEW

SIDE VIEW

Typical Elevations

Scale 1:20

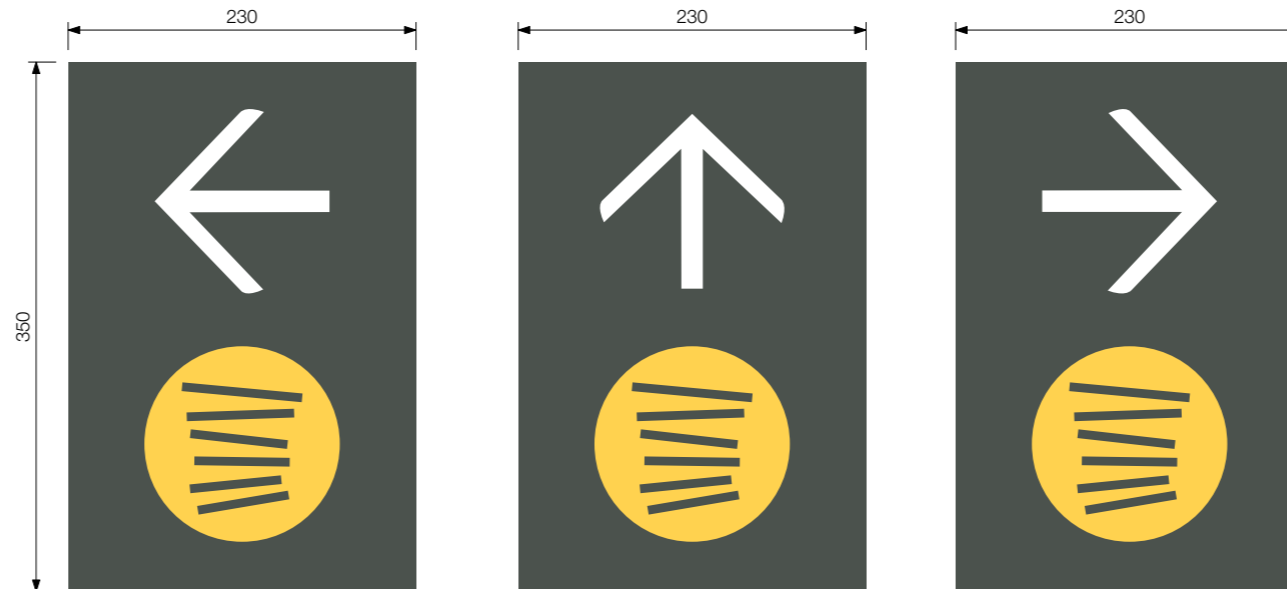

TURN LEFT

STRAIGHT AHEAD

TURN RIGHT

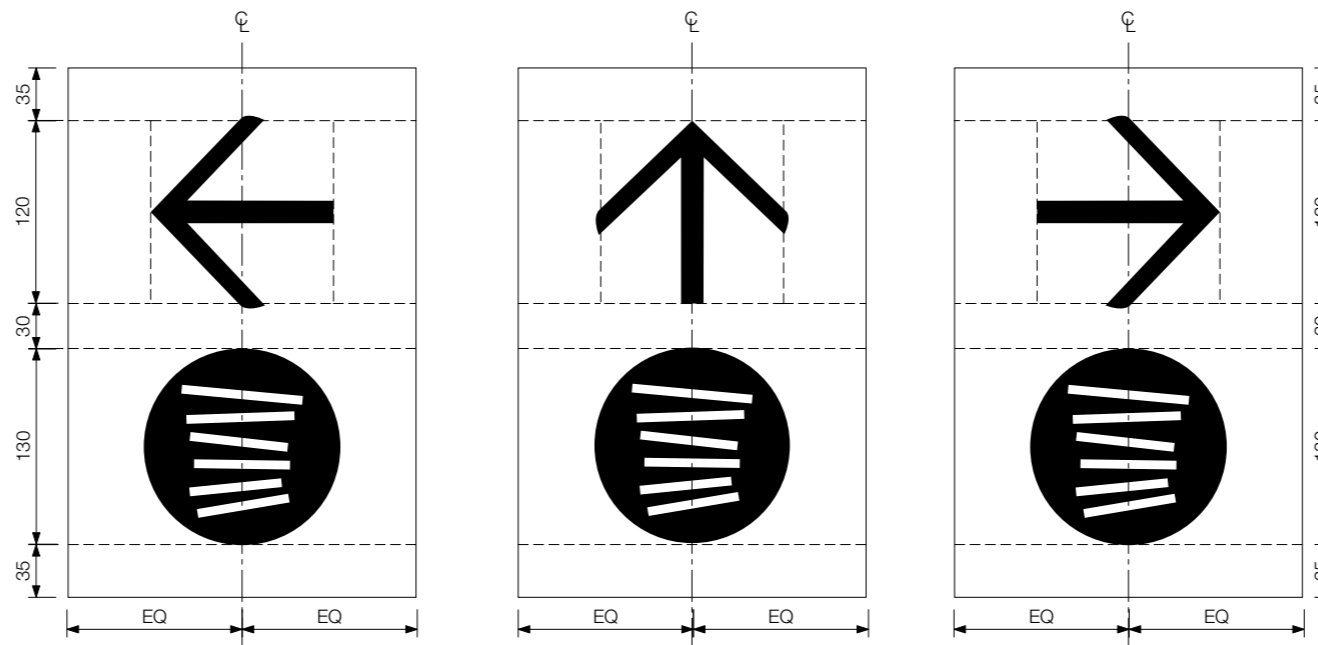

TURN LEFT

STRAIGHT AHEAD

TURN RIGHT

Graphic Detail

Scale 1:5

TIER 2 SUPPLEMENTARY SIGNS

Sign type 2.2
Directional sign
Sheet 1 of 2

Unless otherwise noted all dimensions in millimetres. Use figured dimensions in preference to scaling. Contractor to confirm all dimensions and details on site prior to manufacture.

Signmaker to confirm all details for approval on shop drawings prior to manufacture. All structural members, fixings and/or footings to be confirmed by sign maker's engineer.

Due to this reproduction process the colours in this image are not exact representations of the final product.

LOCATION PRINCIPLES

Located where there is possible ambiguity in the pathway route, including major junctions and open areas. Also used at pathway exits to the surrounding street network to promote safety and connectivity to community.

CONSTRUCTION DETAILS

TIMBER BOLLARD

Timber is to be F27 Kiln Dried Hardwood Class 1 Durability rating - Queensland Spotted Gum or Queensland Iron Bark or similar if unavailable. Dressed/machined timber to specified size. Tanalith E / ACQ Treatment, CN oil finish top coat and treated with Tanacoat oil.

SIGN PANELS

2mm thick fabricated aluminium sign panel fixed flush to face of timber column. Full colour digital print on polymeric vinyl with anti graffiti polyvinyl fluoride film over.

FOOTINGS

Reinforced no-fines concrete pad/pier footing to signmakers' engineer specification. All fixings shall be below ground level to reduce trip hazards. Re-instate / make good paving or pavement, with no changes of level and no gradients steeper than 1:40.

ALTERNATIVE BOLLARD OPTION

RECYCLED PLASTIC BOLLARD

Bollard = 'The Marion' by Replas Recycled Plastic Products
Size = 200mm wide x 75mm thick
Colour = Replas Grey

Refer www.replas.com.au

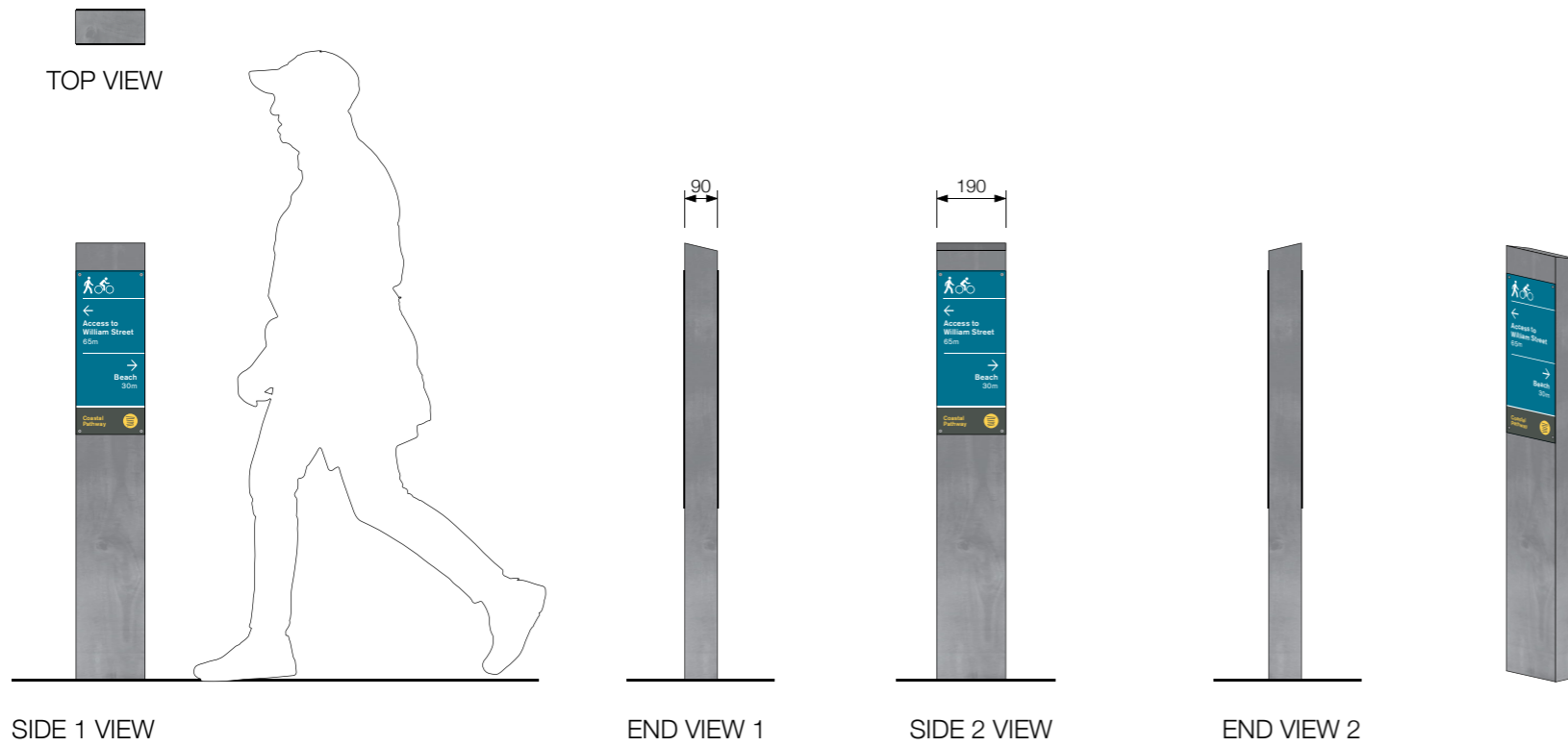

Typical Elevations

Scale 1:20

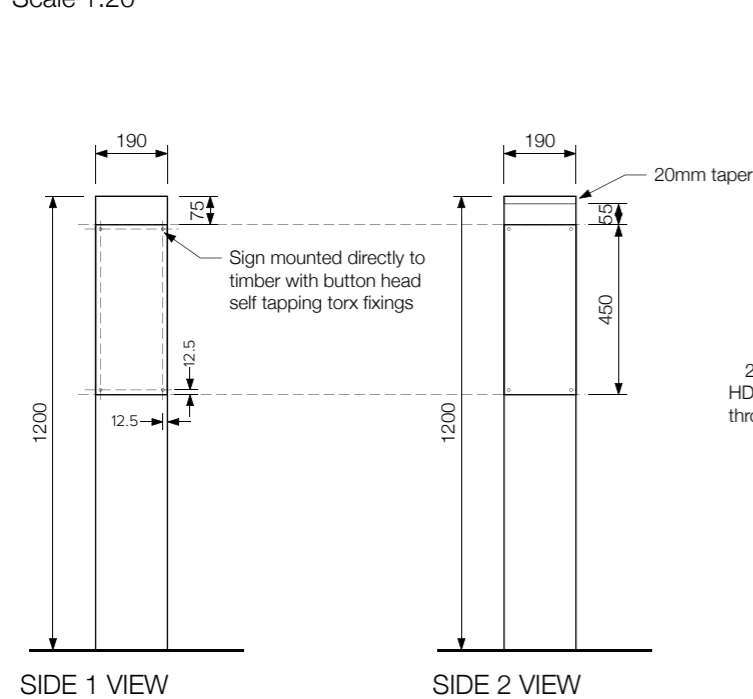

Dimensions

Scale 1:20

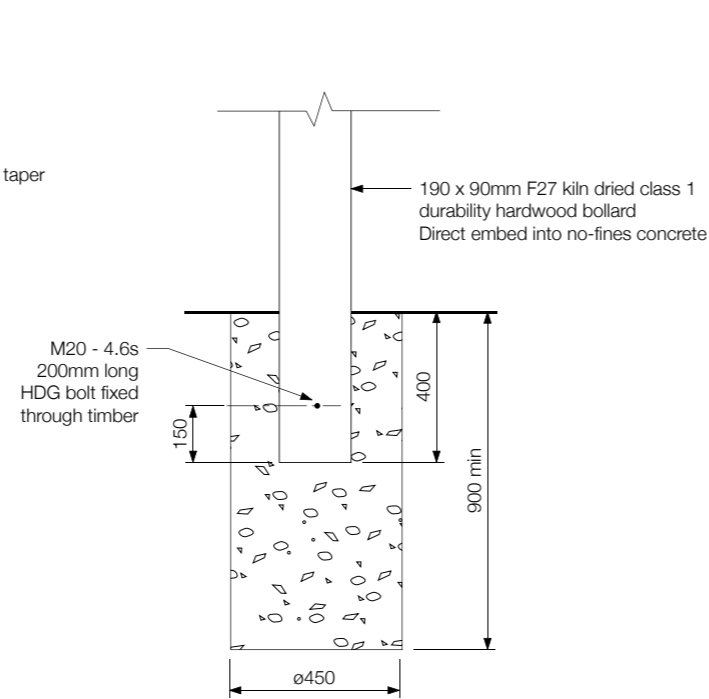

Direct Embed Footing Detail

Scale 1:20

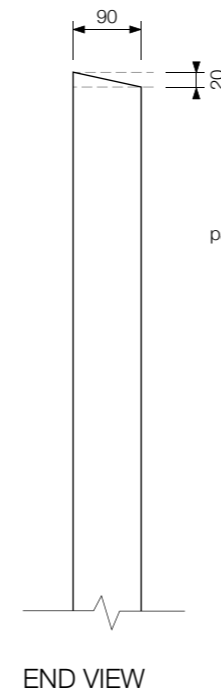

Tapered Detail

Scale 1:10

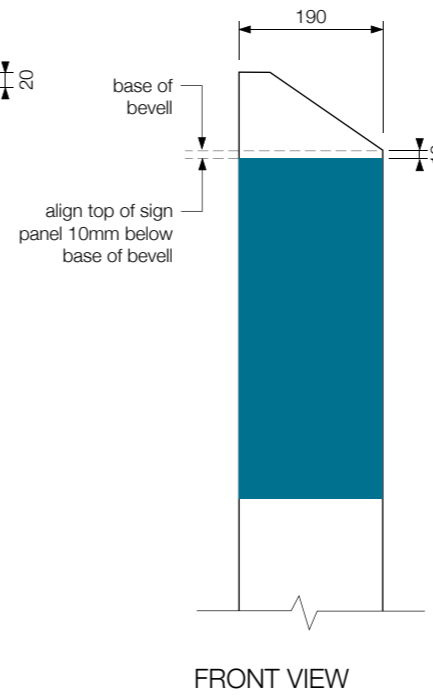

Recycled Plastic Detail

Scale 1:10

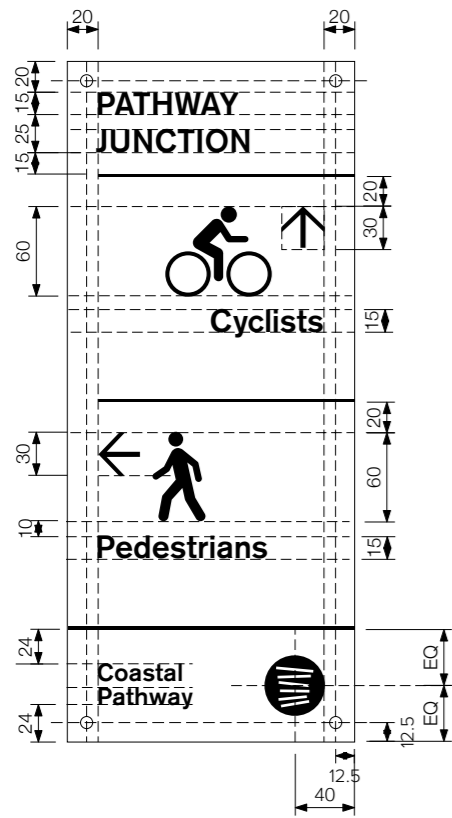
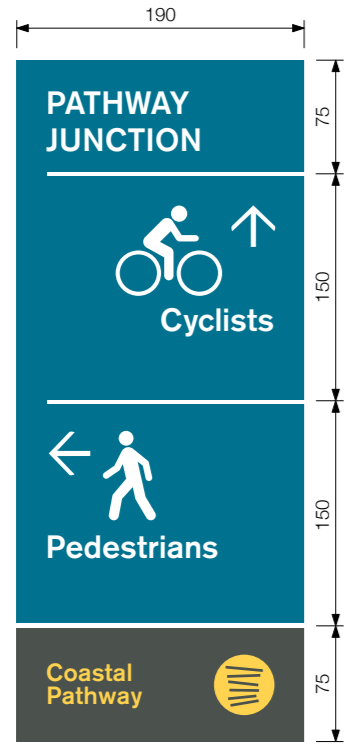

Eg. Pathway divide

Typical Graphic Layouts

Scale 1:5

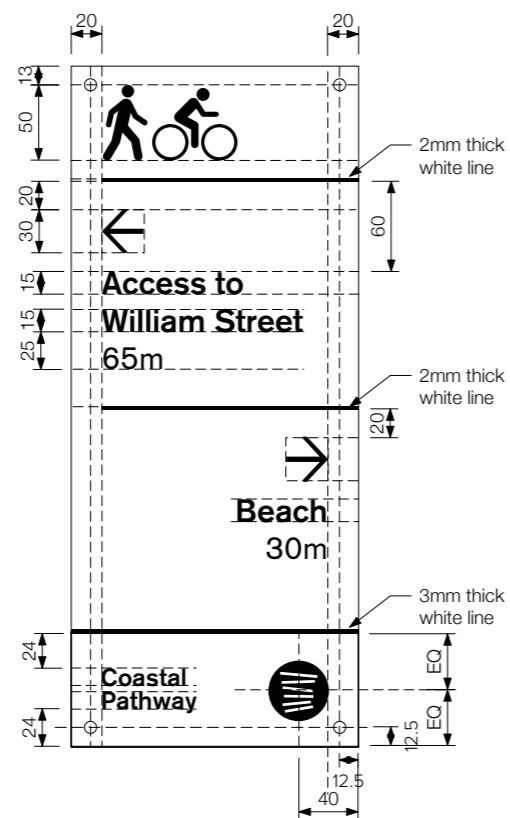

Eg. Facilities/ destinations off pathway

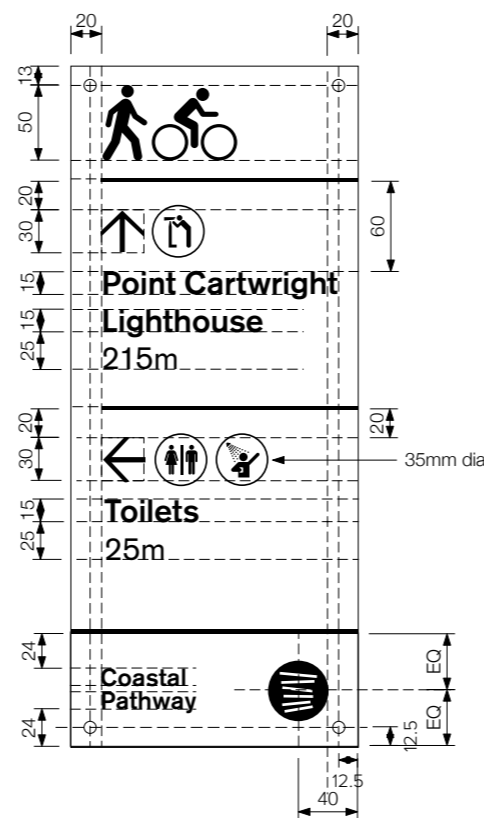

Eg. Facilities/ destinations off pathway

TIER 2 SUPPLEMENTARY SIGNS

Sign type 2.2
Directional sign
Sheet 2 of 2

Unless otherwise noted all dimensions in millimetres. Use figured dimensions in preference to scaling. Contractor to confirm all dimensions and details on site prior to manufacture.

Signmaker to confirm all details for approval on shop drawings prior to manufacture. All structural members, fixings and/or footings to be confirmed by sign maker's engineer.

Due to this reproduction process the colours in this image are not exact representations of the final product.

GRAPHIC LAYOUT DETAILS

FULL COLOUR DIGITAL PRINT
190 x 450mm full colour digital print (including Sign and Footer panels) onto polymetric vinyl with anti graffiti polyvinyl fluoride film over.

Font

Destination = Akzidenz Grotesk Medium
Distance = Akzidenz Grotesk Regular

Colour

SIGN PANEL
Background = PMS 315C
Graphics = Avery White Matt 920
Shared path pictograms = Avery White Matt 920
Pictograms = Avery White Matt 920

FOOTER PANEL

Background = Colorbond Woodland Grey
Coastal Pathway = PMS 122C

TIER 2 SUPPLEMENTARY SIGNS

Sign type 2.3
Warning information sign
Sheet 1 of 2

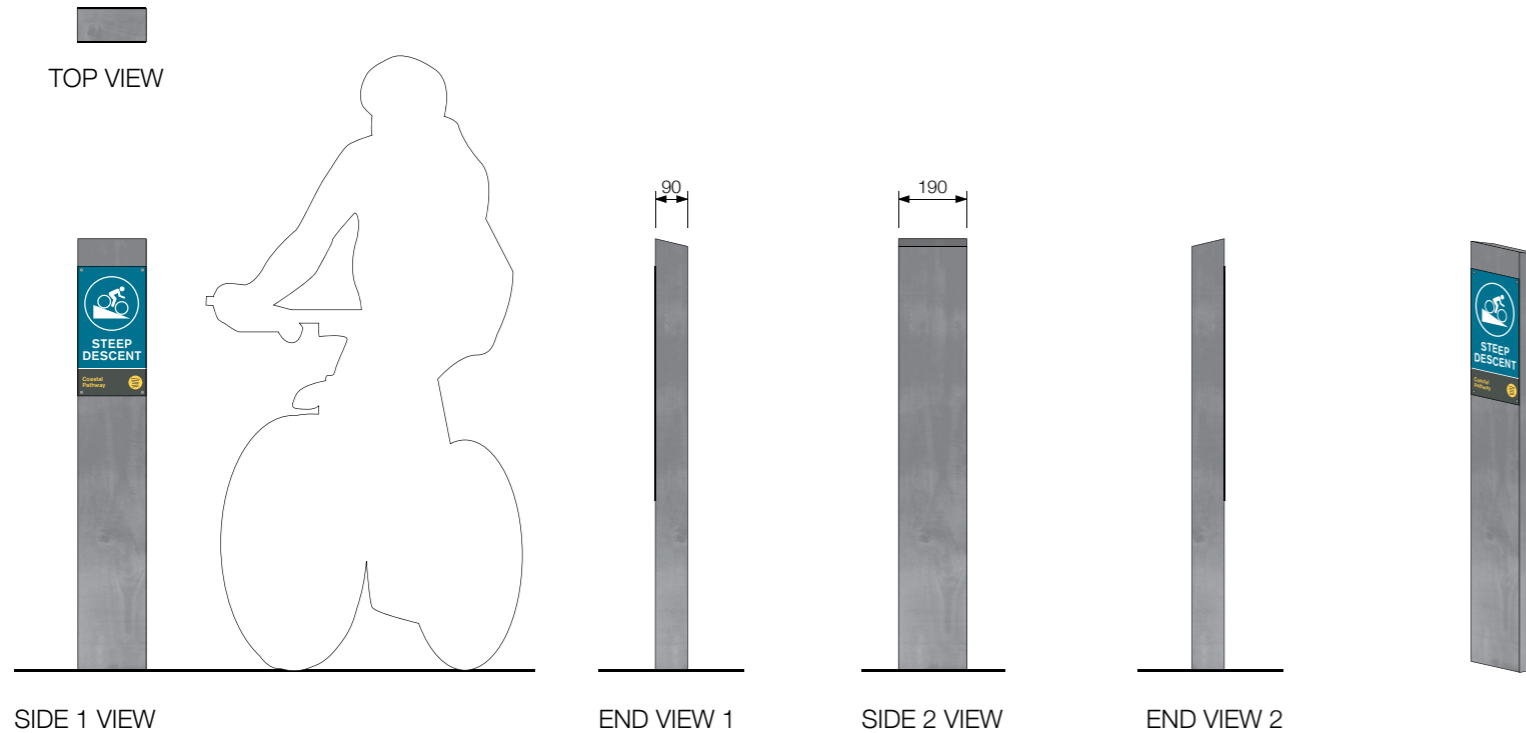

Typical Elevations

Scale 1:20

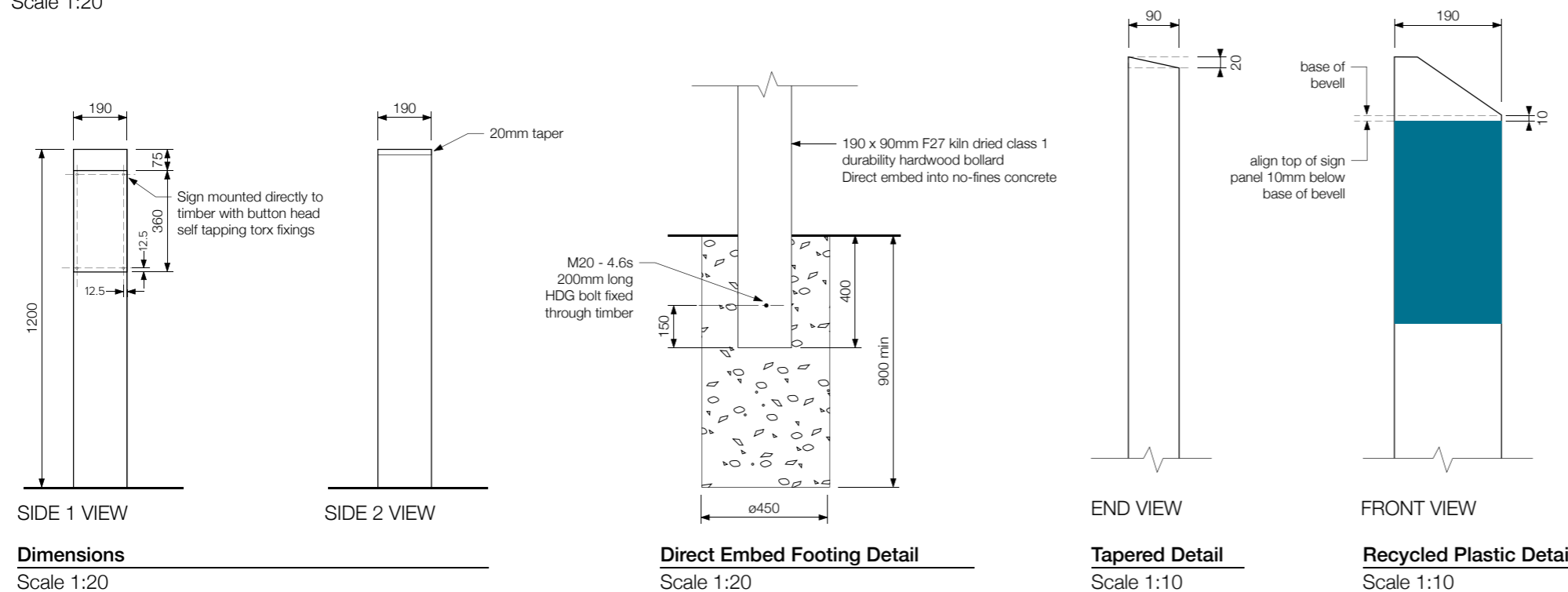

Unless otherwise noted all dimensions in millimetres. Use figured dimensions in preference to scaling. Contractor to confirm all dimensions and details on site prior to manufacture.

Signmaker to confirm all details for approval on shop drawings prior to manufacture. All structural members, fixings and/or footings to be confirmed by sign maker's engineer.

Due to this reproduction process the colours in this image are not exact representations of the final product.

LOCATION PRINCIPLES

Located where there is a change in pathway conditions that may endanger the user. Also used at locations where information is required to make aware certain conditions that may effect some user groups such as cross over points.

CONSTRUCTION DETAILS

TIMBER BOLLARD

Timber is to be F27 Kiln Dried Hardwood Class 1 Durability rating - Queensland Spotted Gum or Queensland Iron Bark or similar if unavailable. Dressed/machined timber to specified size. Tanalith E / ACQ Treatment, CN oil finish top coat and treated with Tanacoat oil.

SIGN PANELS

2mm thick fabricated aluminium sign panel fixed flush to face of timber column. Full colour digital print on polymeric vinyl with anti graffiti polyvinyl fluoride film over.

FOOTINGS

Reinforced no-fines concrete pad/pier footing to signmakers' engineer specification. All fixings shall be below ground level to reduce trip hazards. Re-instate / make good paving or pavement, with no changes of level and no gradients steeper than 1:40.

ALTERNATIVE BOLLARD OPTION

RECYCLED PLASTIC BOLLARD

Bollard = 'The Marion' by Replas Recycled Plastic Products
Size = 200mm wide x 75mm thick
Colour = Replas Grey

Refer www.replas.com.au

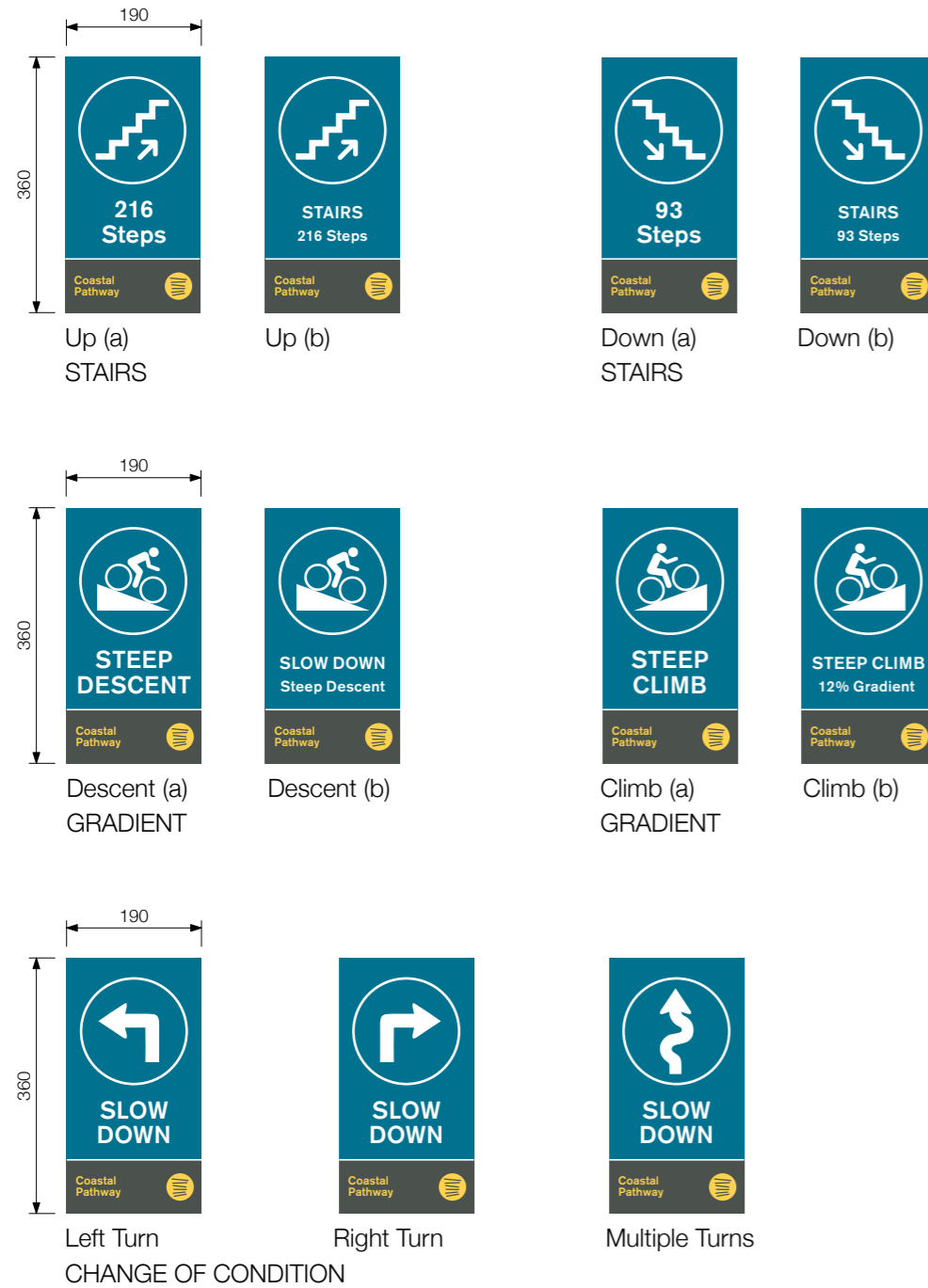

Typical Graphic Layouts

Scale 1:10

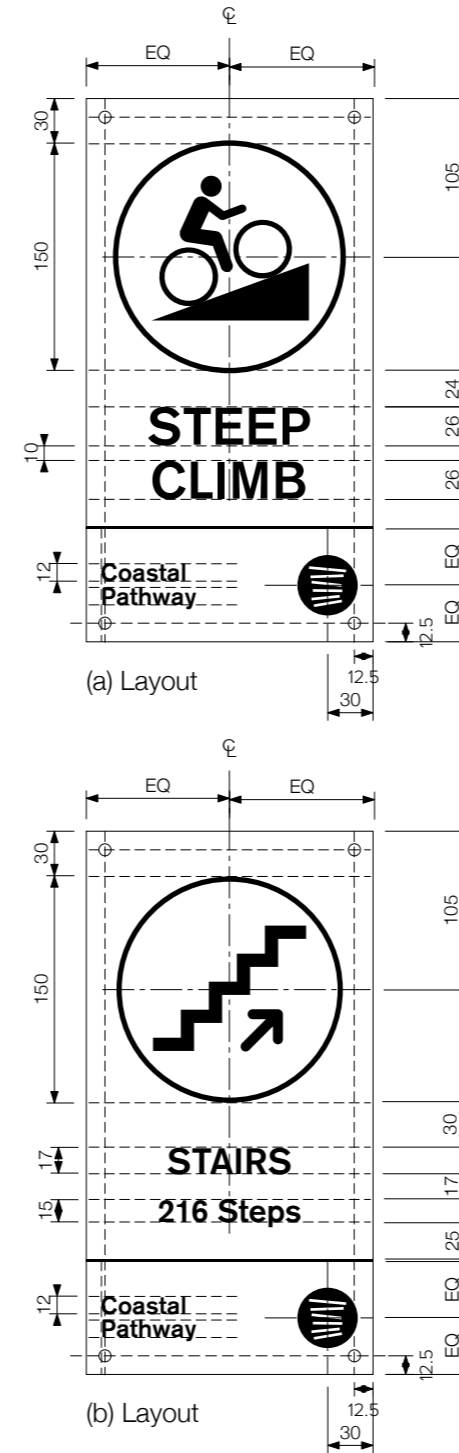

Typical Graphic Detail

Scale 1:5

TIER 2 SUPPLEMENTARY SIGNS

Sign type 2.3
Warning information sign
Sheet 2 of 2

Unless otherwise noted all dimensions in millimetres. Use figured dimensions in preference to scaling. Contractor to confirm all dimensions and details on site prior to manufacture.

Signmaker to confirm all details for approval on shop drawings prior to manufacture. All structural members, fixings and/or footings to be confirmed by sign maker's engineer.

Due to this reproduction process the colours in this image are not exact representations of the final product.

GRAPHIC LAYOUT DETAILS

FULL COLOUR DIGITAL PRINT
190 x 360 full colour digital print (including Sign and Footer panels) onto polymeric vinyl with anti graffiti polyvinyl fluoride film over.

Font

Destination = Akzidenz Grotesk Medium
Distance = Akzidenz Grotesk Regular

Colour

SIGN PANEL
Background = PMS 315C
Graphics = Avery White Matt 920
Pictograms = Avery White Matt 920

FOOTER PANEL

Background = Colorbond Woodland Grey
Coastal Pathway = PMS 122C

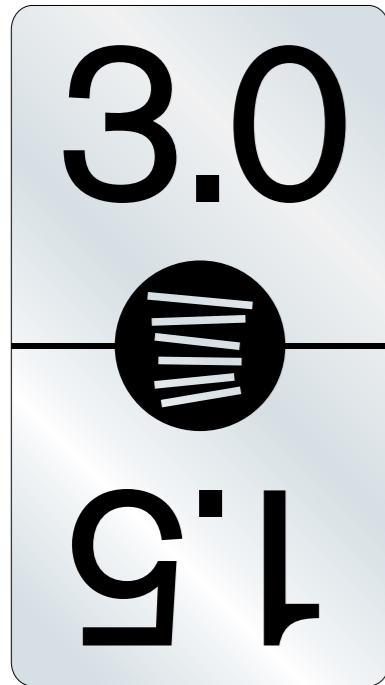

VIEW 1

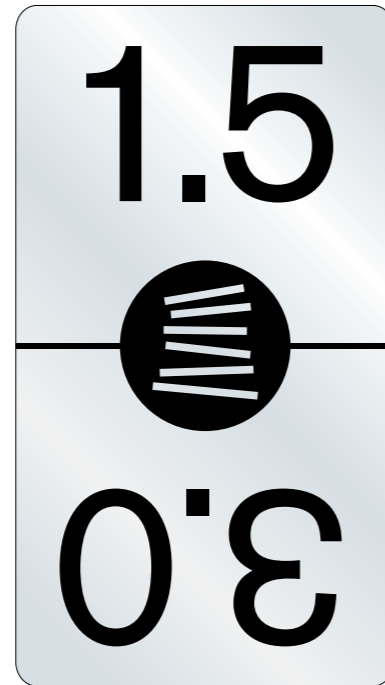

VIEW 2

Typical Graphic Layout

Scale 1:2

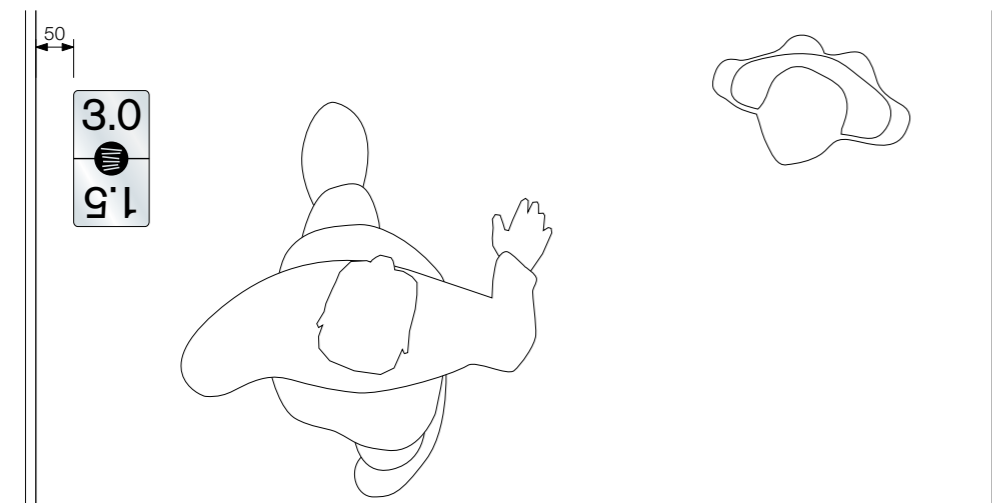

Typical Location Detail

Scale 1:10

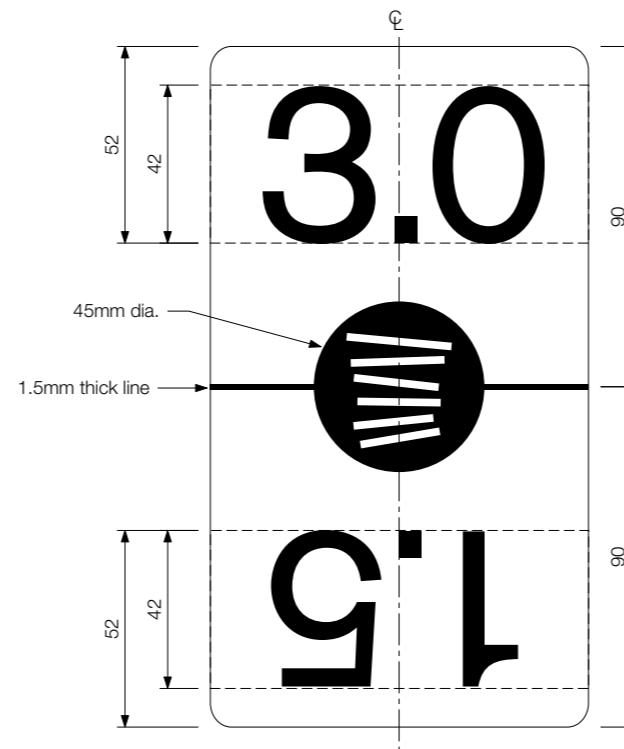

Graphic Layout Detail

Scale 1:2

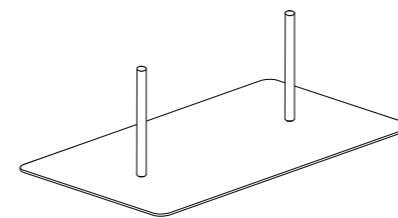

REAR VIEW - PINS

TIER 2 SUPPLEMENTARY SIGNS

**Sign type 2.4
Activity measurement sign
Sheet 1 of 1**

Unless otherwise noted all dimensions in millimetres. Use figured dimensions in preference to scaling. Contractor to confirm all dimensions and details on site prior to manufacture.

Signmaker to confirm all details for approval on shop drawings prior to manufacture. All structural members, fixings and/or footings to be confirmed by sign maker's engineer.

Due to this reproduction process the colours in this image are not exact representations of the final product.

LOCATION PRINCIPLES

Distance markers located along pathway as required.

CONSTRUCTION DETAILS

SIGN PANEL

3mm thick Satin Natural Anodised aluminium with pencilled rounded edges and corners.

GRAPHICS

Graphics to be photo-anodised to front surface of sign panel.

FIXING

Two rear welded pins to back of sign panel and chemset hard to path surface. Pathway surface to be pre-drilled to accommodate pins.

GRAPHIC LAYOUT DETAILS

Font

Distance = Akzidenz Grotesk Regular

Colour

Panel = Satin Natural Anodised aluminium
Graphics = Black

ALTERNATIVE GRAPHICS OPTION

ENGRAVED AND PAINT FILLED

All graphics to be engraved and paint in-filled Black.

TIER 2 SUPPLEMENTARY SIGNS

**Sign type 2.5
Directional Finger Blade
Sheet 1 of 2**

Unless otherwise noted all dimensions in millimetres. Use figured dimensions in preference to scaling. Contractor to confirm all dimensions and details on site prior to manufacture.

Signmaker to confirm all details for approval on shop drawings prior to manufacture. All structural members, fixings and/or footings to be confirmed by sign maker's engineer.

Due to this reproduction process the colours in this image are not exact representations of the final product.

LOCATION PRINCIPLES

Located in urban and park areas to direct and identify the pathway route at missing links. To be used in conjunction with existing traffic/street sign structures.

CONSTRUCTION DETAILS

SIGN PANEL

Panel made from "Heavy Dumbbell" aluminium extrusion or similar.

FIXING

Panel to be fixed to sign post as required.

OPTIONS

Option 1: Includes words "Coastal Pathway" to assist recognition, particularly in tourist areas where there are many first time visitors.

Option 2: Does not include the words and could be utilised in local areas where there are fewer tourists.

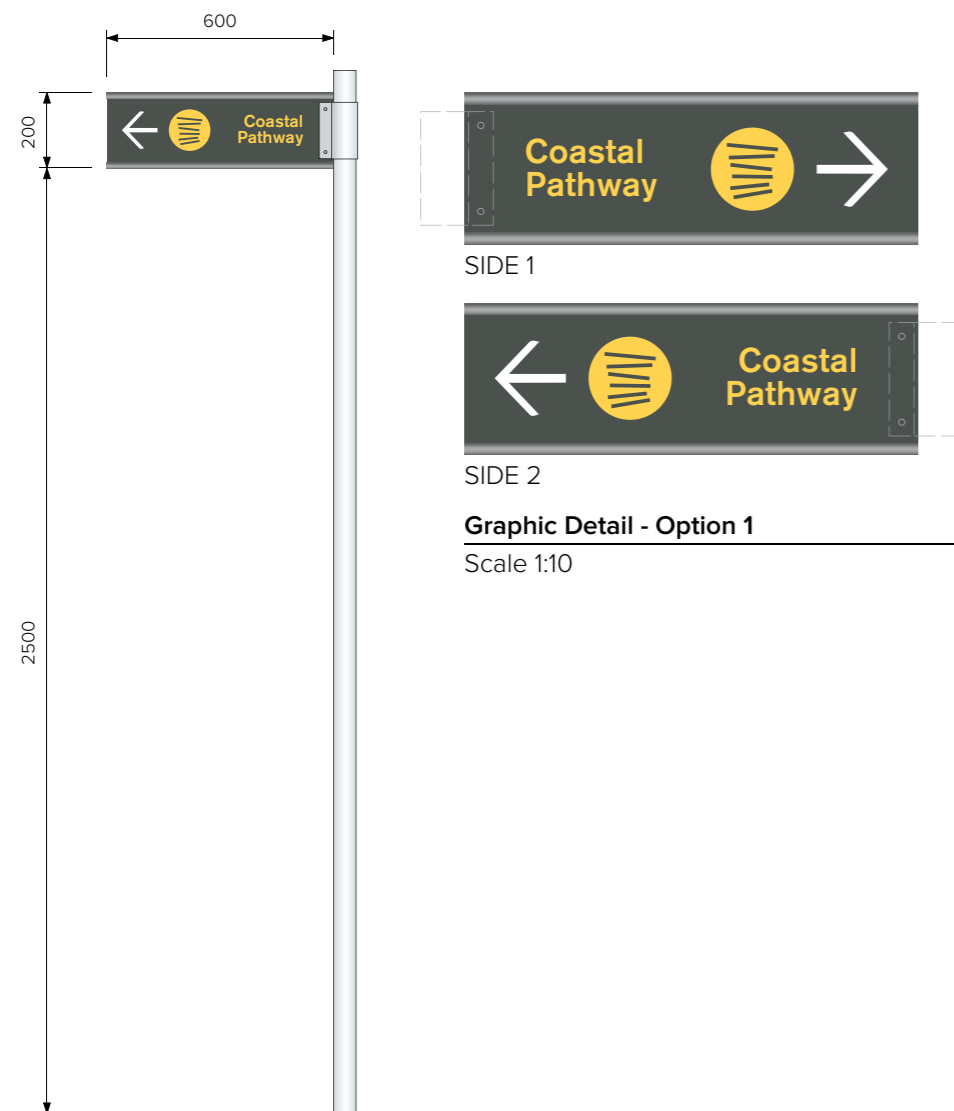

Typical Sign Location - Option 1
Scale 1:20

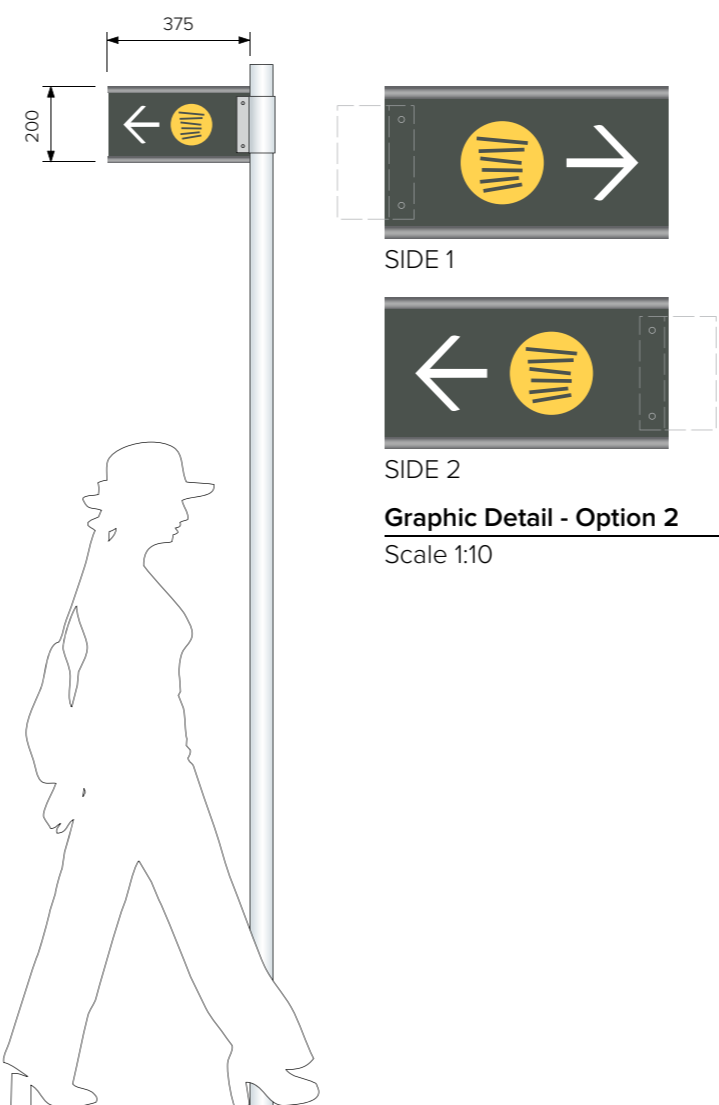

Typical Sign Location - Option 2
Scale 1:20



Typical Application

In environment

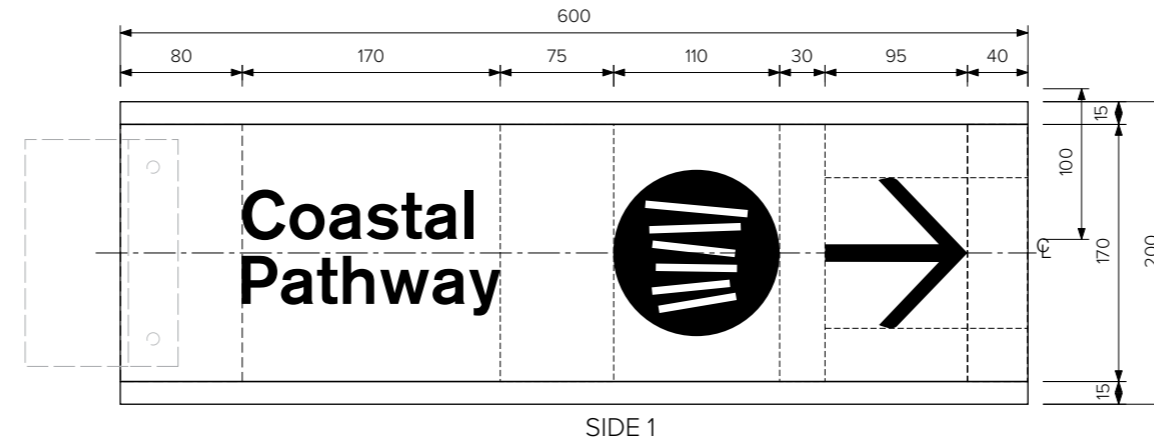

SIDE 1

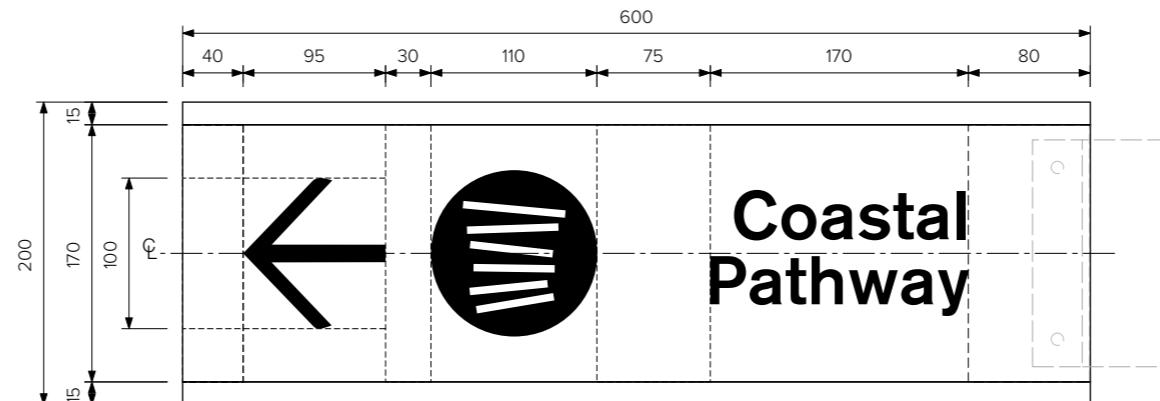

SIDE 2

Graphic Detail - Option 1

Scale 1:5

TIER 2 SUPPLEMENTARY SIGNS

**Sign type 2.5
Directional Finger Blade
Sheet 2 of 2**

Unless otherwise noted all dimensions in millimetres. Use figured dimensions in preference to scaling. Contractor to confirm all dimensions and details on site prior to manufacture.

Signmaker to confirm all details for approval on shop drawings prior to manufacture. All structural members, fixings and/or footings to be confirmed by sign maker's engineer.

Due to this reproduction process the colours in this image are not exact representations of the final product.

GRAPHIC LAYOUT DETAILS

FULL COLOUR DIGITAL PRINT

Option 1: 170 x 600 full colour digital print onto polymeric vinyl with anti graffiti polyvinyl fluoride film over.

Option 2: 170 x 375 full colour digital print onto polymeric vinyl with anti graffiti polyvinyl fluoride film over.

Colour

SIGN PANEL

Background = Colorbond Woodland Grey

Coastal Pathway = PMS 122C

Arrow = White

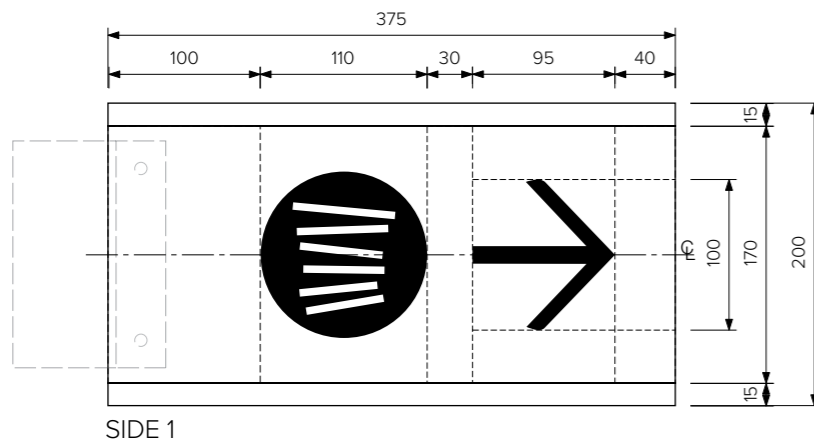

SIDE 1

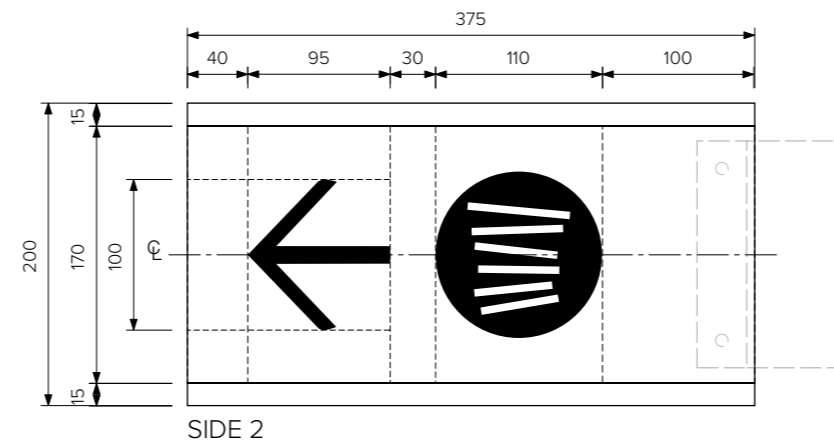

SIDE 2

Graphic Detail - Option 2

Scale 1:5

TIER 2 SUPPLEMENTARY SIGNS

**Sign type 2.6
Directional bollard
Sheet 1 of 2**

Unless otherwise noted all dimensions in millimetres. Use figured dimensions in preference to scaling. Contractor to confirm all dimensions and details on site prior to manufacture.

Signmaker to confirm all details for approval on shop drawings prior to manufacture. All structural members, fixings and/or footings to be confirmed by sign maker's engineer.

Due to this reproduction process the colours in this image are not exact representations of the final product.

LOCATION PRINCIPLES

Located in park/natural areas to direct and identify the pathway route at missing links. To be used where there is no suitable infrastructure to mount a Directional finger blade.

CONSTRUCTION DETAILS

TIMBER BOLLARD

Timber is to be F27 Kiln Dried Hardwood Class 1 Durability rating - Queensland Spotted Gum or Queensland Iron Bark or similar if unavailable. Dressed/machined timber to specified size. Tanalith E / ACQ Treatment, CN oil finish top coat and treated with Tanacoat oil.

SIGN PANELS

2mm thick fabricated aluminium sign panel fixed flush to face of timber column. Full colour digital print on polymeric vinyl with anti graffiti polyvinyl fluoride film over.

FOOTINGS

Reinforced no-fines concrete pad/pier footing to signmakers' engineer specification. All fixings shall be below ground level to reduce trip hazards. Re-instate / make good paving or pavement, with no changes of level and no gradients steeper than 1:40.

ALTERNATIVE BOLLARD OPTION

RECYCLED PLASTIC BOLLARD

Bollard = 'The Marion' by Replas Recycled Plastic Products
Size = 200mm wide x 75mm thick
Colour = Replas Grey

Refer www.replas.com.au

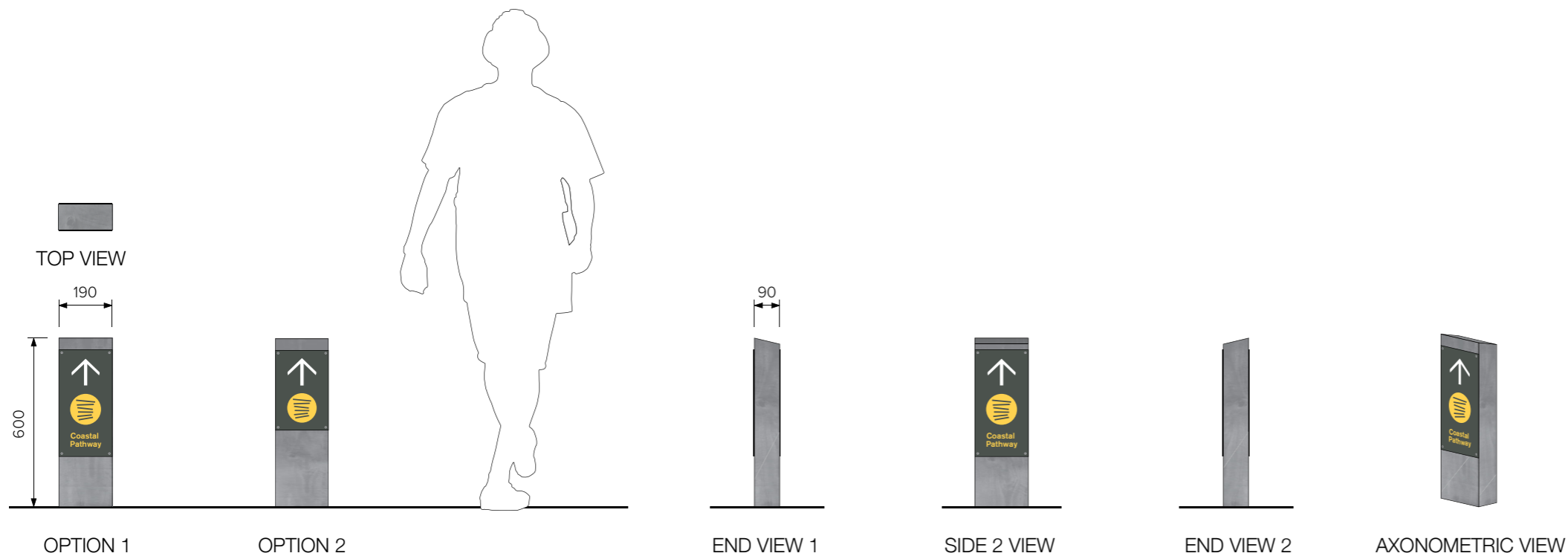

Typical Elevations

Scale 1:20

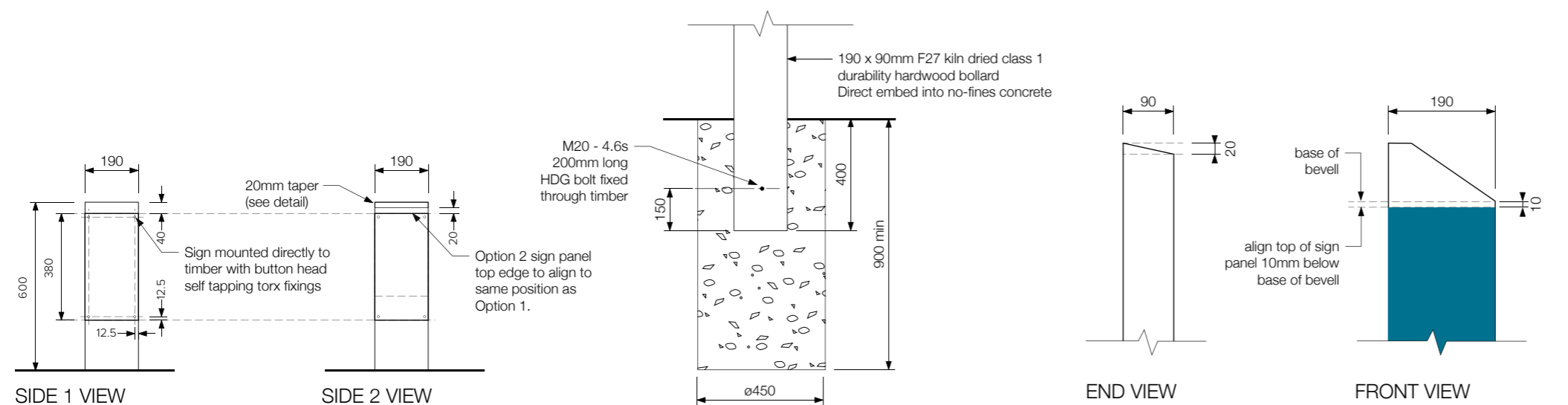

Dimensions

Scale 1:20

Direct Embed Footing Detail

Scale 1:20

Tapered Detail

Scale 1:10

Recycled Plastic Detail

Scale 1:10

TIER 2 SUPPLEMENTARY SIGNS

**Sign type 2.6
Directional bollard
Sheet 2 of 2**

Unless otherwise noted all dimensions in millimetres. Use figured dimensions in preference to scaling. Contractor to confirm all dimensions and details on site prior to manufacture.

Signmaker to confirm all details for approval on shop drawings prior to manufacture. All structural members, fixings and/or footings to be confirmed by sign maker's engineer.

Due to this reproduction process the colours in this image are not exact representations of the final product.

GRAPHIC LAYOUT DETAILS

FULL COLOUR DIGITAL PRINT

Option 1: 380 x 190 full colour digital print onto polymeric vinyl with anti graffiti polyvinyl fluoride film over.

Option 2: 295 x 190 full colour digital print onto polymeric vinyl with anti graffiti polyvinyl fluoride film over.

Colour

SIGN PANEL

Background = Colorbond Woodland Grey

Coastal Pathway = PMS 122C

Arrow = White



Typical Application
In environment



Graphic Detail - Option 1
Scale 1:5

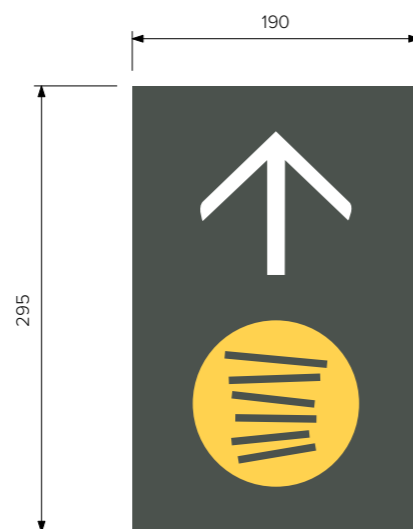

Graphic Detail - Option 2
Scale 1:5

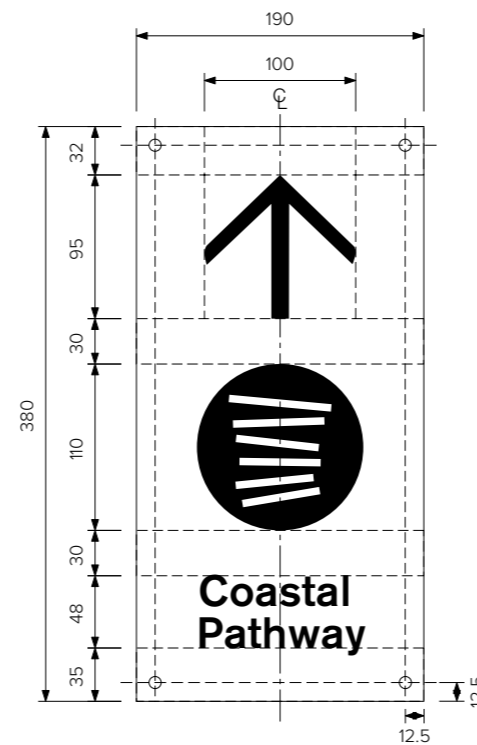

Graphic Detail - Option 1
Scale 1:5

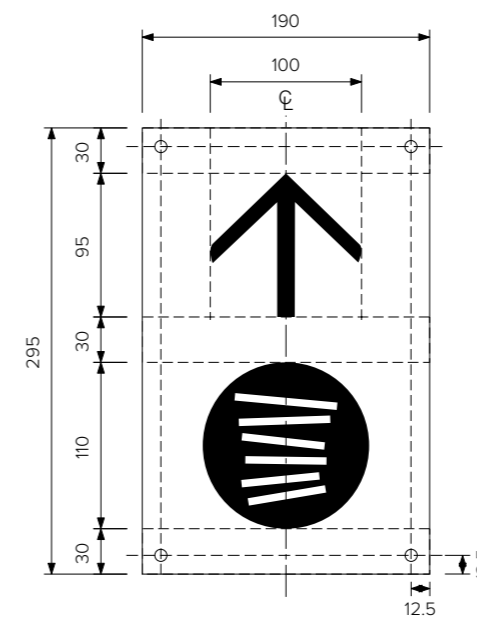

Graphic Detail - Option 2
Scale 1:5

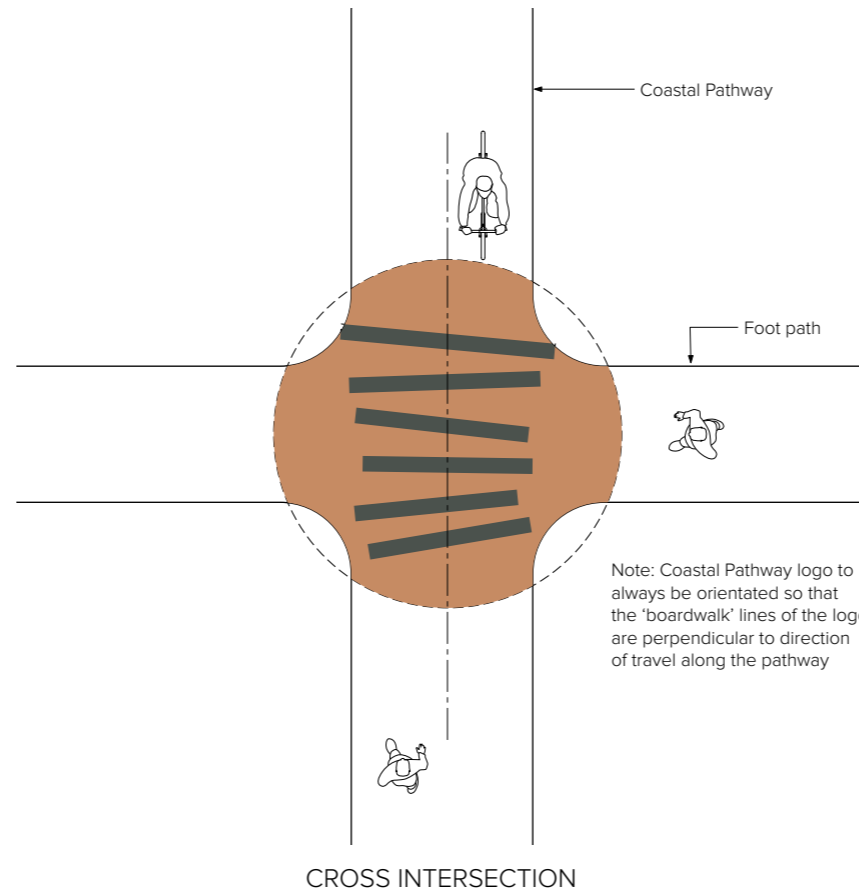
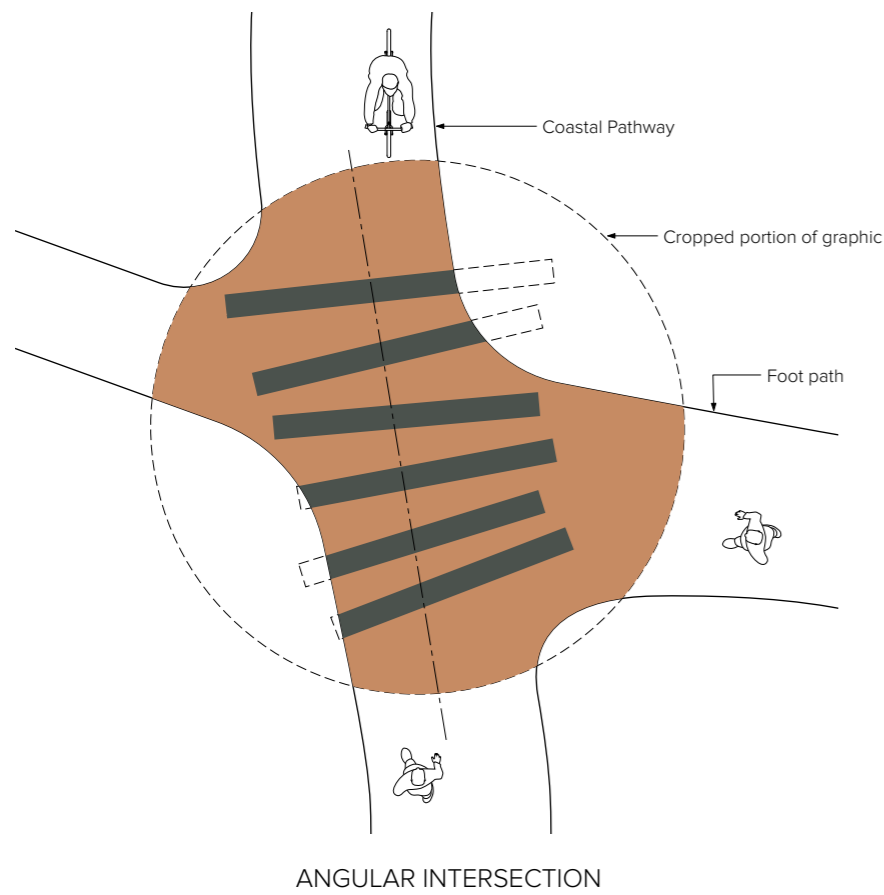

TIER 3 BEHAVIOURAL SIGNS

**Sign type 3.1
Cross over graphic
Sheet 1 of 3**

Unless otherwise noted all dimensions in millimetres. Use figured dimensions in preference to scaling. Contractor to confirm all dimensions and details on site prior to manufacture.

Signmaker to confirm all details for approval on shop drawings prior to manufacture. All structural members, fixings and/or footings to be confirmed by sign maker's engineer.

Due to this reproduction process the colours in this image are not exact representations of the final product.

LOCATION PRINCIPLES

Located at potential conflict zones along the pathway. These are usually at major intersections that provide access to beaches, parks, buildings and adjacent roads.

CONSTRUCTION DETAILS

"StreetBond" or similar pavement surfacing treatment is to be applied to pathway at major cross-over intersections. Treatment to be applied direct to concrete pavement. Colours to have minimum 30% contrast for legibility.

High impact supergraphic provides a visual warning of potential hazards at intersections. Scale and crop of each graphic varies to suit size and configuration of intersection.

Examples show ideal applications of cross over graphic.

Colour

Noted on sheet 2

Typical Ground Graphic Placement and Crop

Scale 1:100

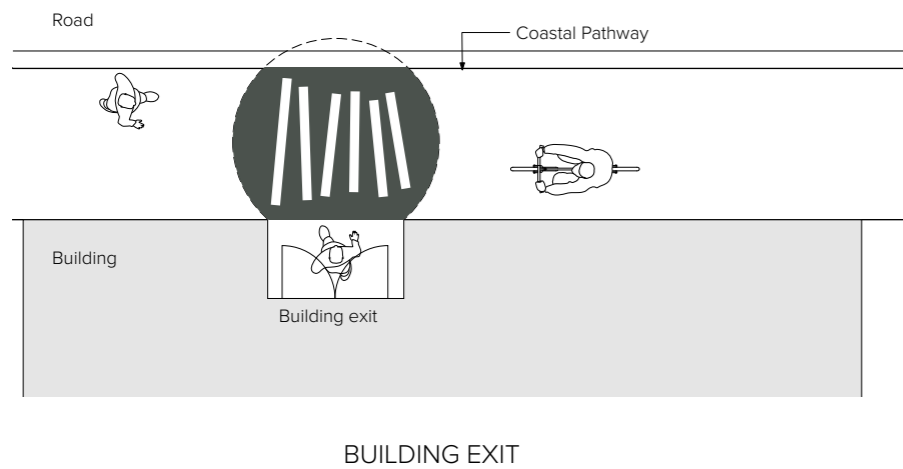

Typical Ground Graphic Placement and Crop

Scale 1:100

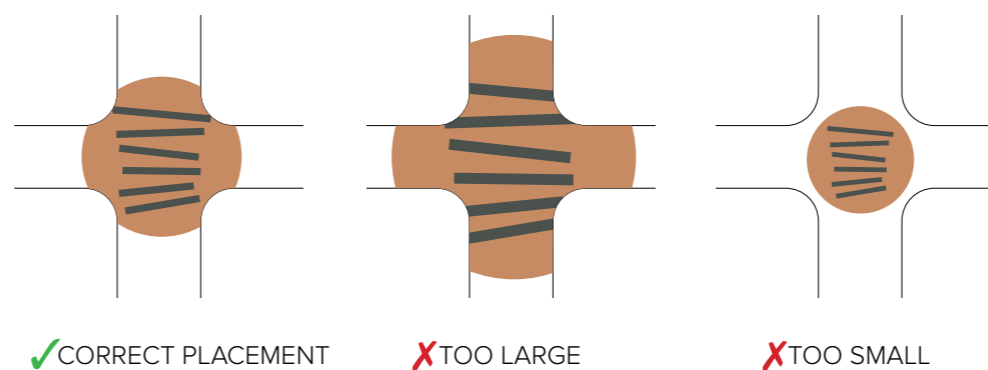

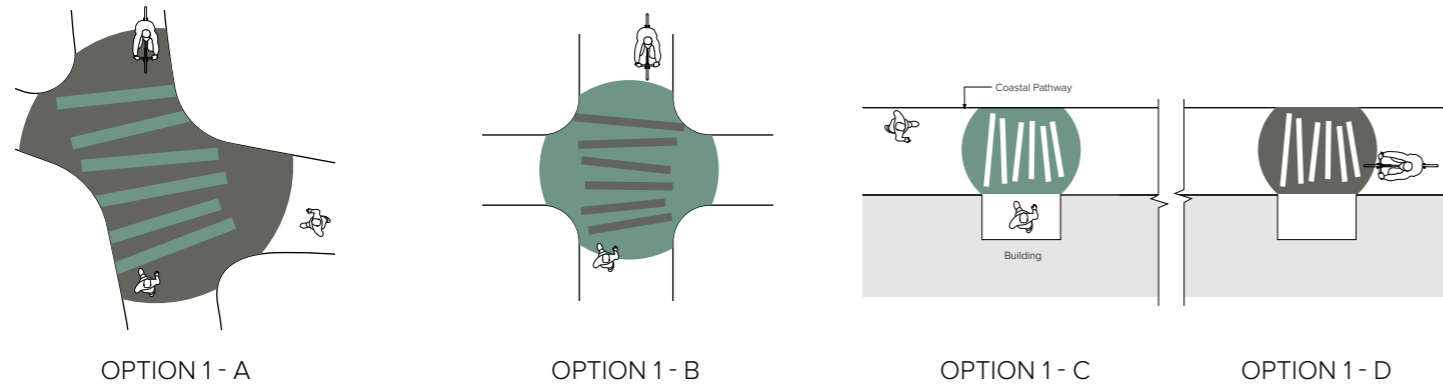

Ground Graphic Crop Guide

Not to scale



COLOURS



-  **StreetBond**
Graphite
-  **StreetBond**
Seafoam
-  No fill

Typical Ground Graphic Placement

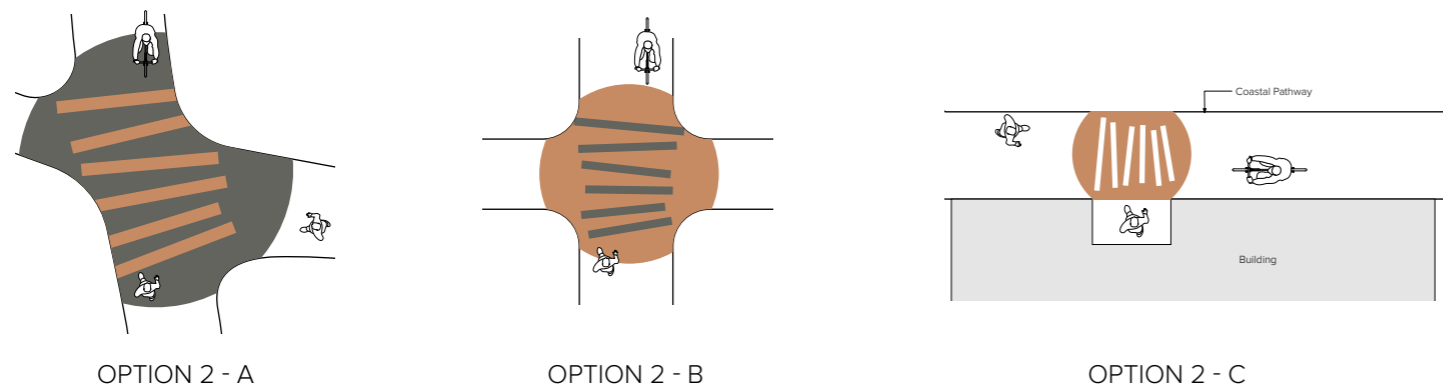
Colour Option 1

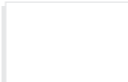

COLOURS

-  **StreetBond**
Graphite
-  **StreetBond**
Sunbaked Clay
-  No fill

Typical Ground Graphic Placement

Colour Option 2

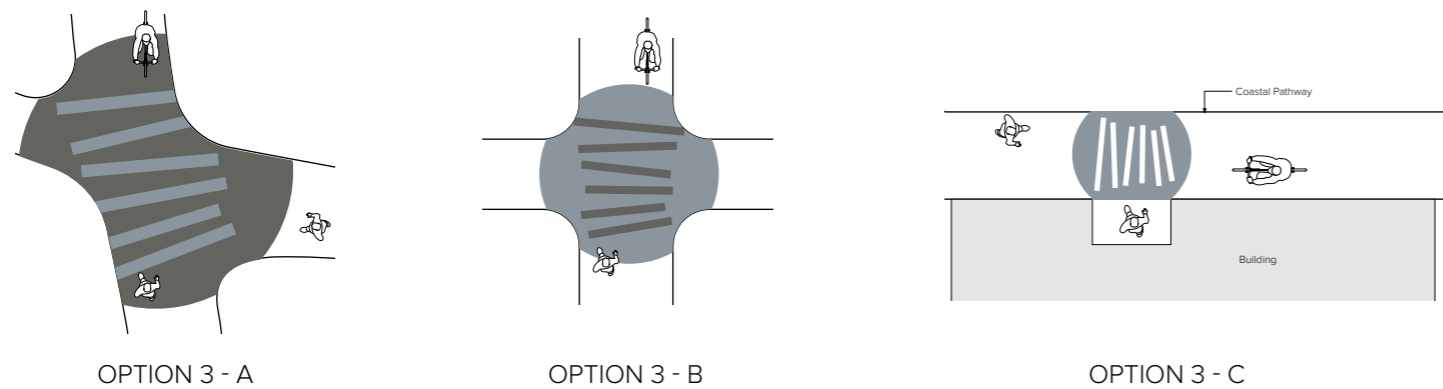

COLOURS

-  **StreetBond**
Graphite
-  **StreetBond**
Gunmetal Grey
-  No fill

Typical Ground Graphic Placement

Colour Option 3

TIER 3 BEHAVIOURAL SIGNS
Sign type 3.1
Cross over graphic
Sheet 2 of 3

Unless otherwise noted all dimensions in millimetres. Use figured dimensions in preference to scaling. Contractor to confirm all dimensions and details on site prior to manufacture.

Signmaker to confirm all details for approval on shop drawings prior to manufacture. All structural members, fixings and/or footings to be confirmed by sign maker's engineer.

Due to this reproduction process the colours in this image are not exact representations of the final product.

GRAPHIC LAYOUT DETAILS

Application of subdued colour options for both bushland and built-up/urban settings.

Use specified colour options from "StreetBond" or similar colour chart that will compliment the surrounding environment and provide sufficient contrast to pavement surface. Potential to use a single colour for larger graphic elements and leave the "boardwalk" with no fill to create contrast with the path.

Colour
Options as noted

TIER 3 BEHAVIOURAL SIGNS

**Sign type 3.1
Cross over graphic
Sheet 3 of 3**

Unless otherwise noted all dimensions in millimetres. Use figured dimensions in preference to scaling. Contractor to confirm all dimensions and details on site prior to manufacture.

Signmaker to confirm all details for approval on shop drawings prior to manufacture. All structural members, fixings and/or footings to be confirmed by sign maker's engineer.

Due to this reproduction process the colours in this image are not exact representations of the final product.

NOTES

High impact supergraphic provides a visual warning of potential hazards at intersections. Scale and crop of each graphic varies to suit size and configuration of intersection. Examples shown provide sample of colour options and the graphic in context.



Angular intersection graphic location example - Colour Option 1 - B



Cross intersection graphic location example - Colour Option 2 - B



Building exit graphic location example - Colour Option 3 - B

Typical Ground Graphic Placement

All locations

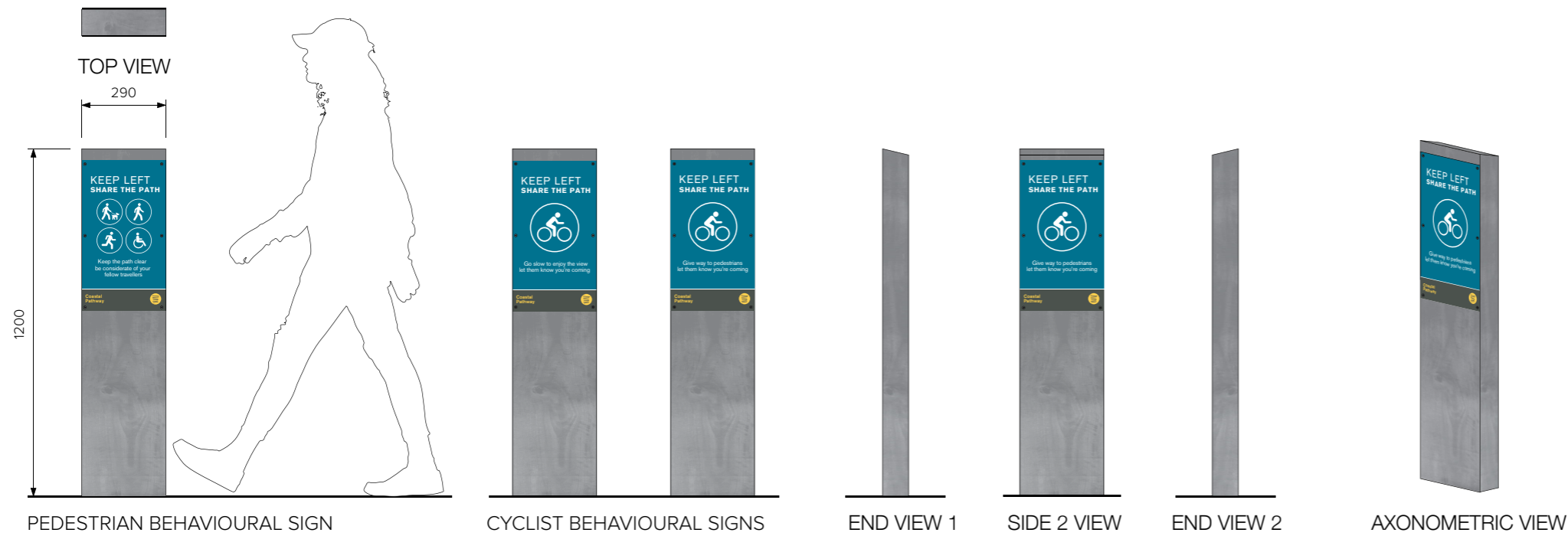

Typical Sign Location

Scale 1:20

TIER 3 BEHAVIOURAL SIGNS

**Sign type 3.2
Behavioural sign
Sheet 1 of 2**

Unless otherwise noted all dimensions in millimetres. Use figured dimensions in preference to scaling. Contractor to confirm all dimensions and details on site prior to manufacture.

Signmaker to confirm all details for approval on shop drawings prior to manufacture. All structural members, fixings and/or footings to be confirmed by sign maker's engineer.

Due to this reproduction process the colours in this image are not exact representations of the final product.

LOCATION PRINCIPLES

Located regularly along pathway to advise all user groups of their behavioural obligations. Used to support cross over ground graphics on all approaches to intersection.

Signs are to be clustered with other built elements along the path to reduce overall visual clutter. Use natural backdrops (shrubs, landform) to reduce overall visual impact. Avoid placing signs in the middle of large open spaces. Ensure the placement of signs doesn't detract from significant views.

CONSTRUCTION DETAILS

TIMBER BOLLARD

Timber is to be F27 Kiln Dried Hardwood Class 1 Durability rating - Queensland Spotted Gum or Queensland Iron Bark or similar if unavailable. Dressed/machined timber to specified size. Tanalith E / ACQ Treatment, CN oil finish top coat and treated with Tanacoat oil.

SIGN PANELS

2mm thick fabricated aluminium sign panel fixed flush to face of timber column. Full colour digital print on polymeric vinyl with anti graffiti polyvinyl fluoride film over.

FOOTINGS

Reinforced no-fines concrete pad/pier footing to signmakers' engineer specification. All fixings shall be below ground level to reduce trip hazards. Re-instate / make good paving or pavement, with no changes of level and no gradients steeper than 1:40.

ALTERNATIVE BOLLARD OPTION

RECYCLED PLASTIC BOLLARD

Bollard = 'The Marion' by Replas Recycled Plastic Products
Size = 200mm wide x 75mm thick
Colour = Replas Grey

Refer www.replas.com.au

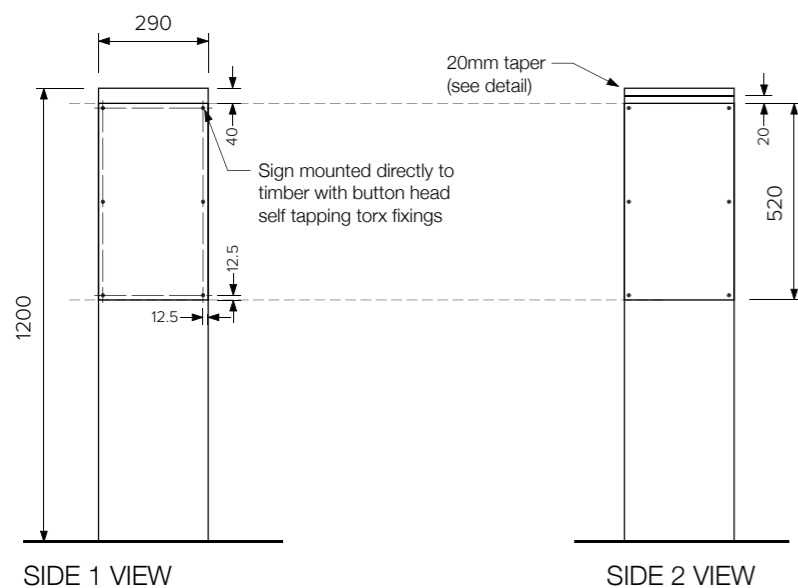

Dimensions

Scale 1:20

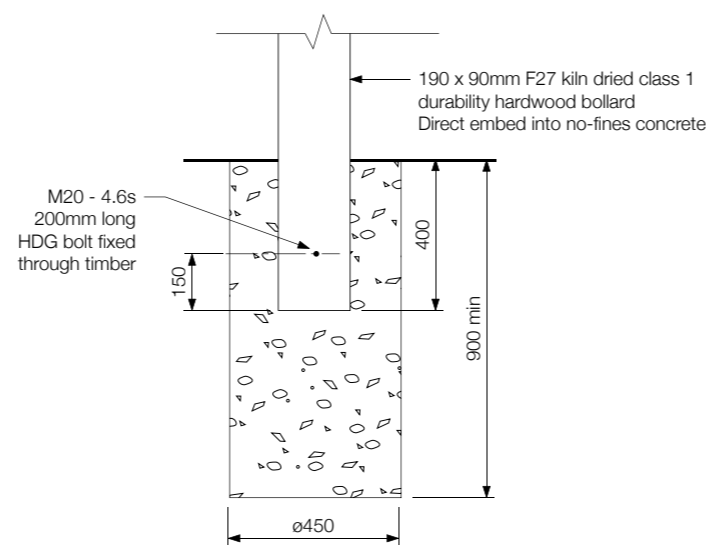

Direct Embed Footing Detail

Scale 1:20

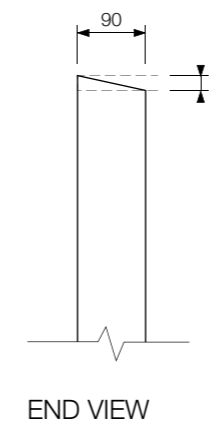

Tapered Detail

Scale 1:10



PEDESTRIAN BEHAVIOURAL SIGN

CYCLIST BEHAVIOURAL SIGNS



Typical Application

In environment

TIER 3 BEHAVIOURAL SIGNS

**Sign type 3.2
Behavioural sign
Sheet 2 of 2**

Unless otherwise noted all dimensions in millimetres. Use figured dimensions in preference to scaling. Contractor to confirm all dimensions and details on site prior to manufacture.

Signmaker to confirm all details for approval on shop drawings prior to manufacture. All structural members, fixings and/or footings to be confirmed by sign maker's engineer.

Due to this reproduction process the colours in this image are not exact representations of the final product.

Graphic Detail

Scale 1:10

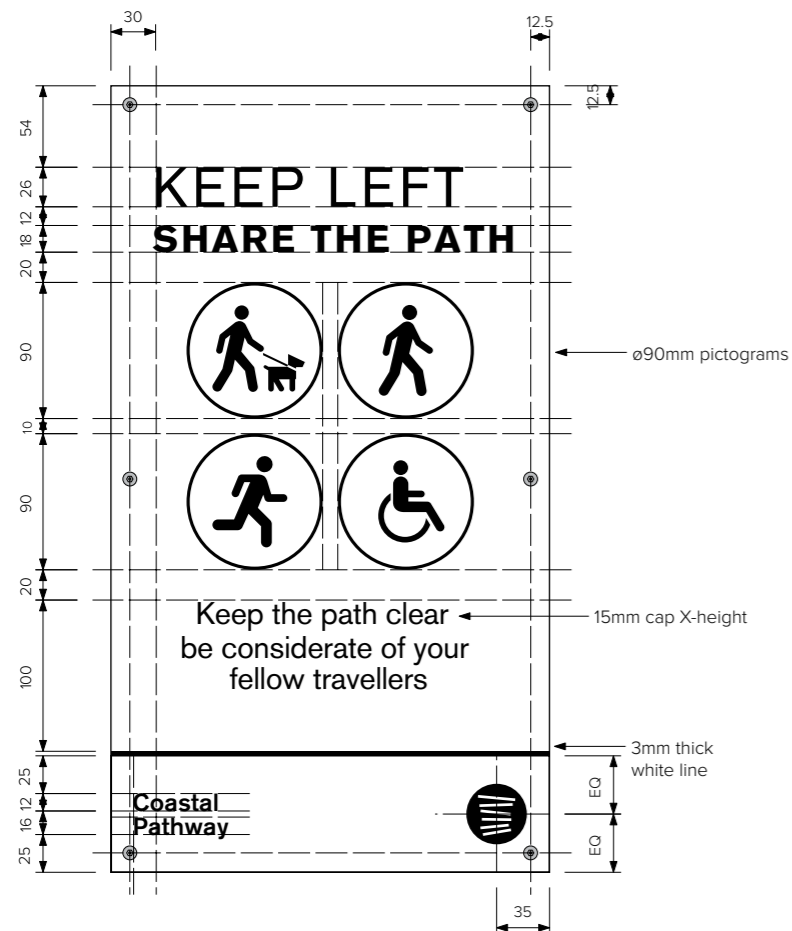

Graphic Detail

Scale 1:5



GRAPHIC LAYOUT DETAILS

FULL COLOUR DIGITAL PRINT
290 x 520mm full colour digital print (including Sign and Footer panels) onto polymeric vinyl with anti graffiti polyvinyl fluoride film over.

Font

Destination = Akzidenz Grotesk Medium
Distance = Akzidenz Grotesk Regular

Colour

SIGN PANEL
Background = PMS 315C
Graphics = Avery White Matt 920
Shared path pictograms = Avery White Matt 920
Pictograms = Avery White Matt 920

FOOTER PANEL

Background = Colorbond Woodland Grey
Coastal Pathway = PMS 122C

D

SIGN SPECIFICATION

Codes and standards

Quality management

Fabrication, finishes and installation

Construction standards

Graphic standards

Installation standards

Codes and standards

All work and materials shall comply with the Building Code of Australia, the Workplace Health and Safety Act, and, except where otherwise noted in this Specification, comply with the latest editions of all relevant Australian codes or standards (current issue) of which the following is a selected list:

Quality management

AS/NZS ISO 9001 Quality systems for design/ development, production, installation and servicing

METALWORK

AS 1170.2-2002 Minimum design loads on structures – wind loads

AS 1627 Metal finishing – preparation and pre-treatment of surfaces

Part 1 – cleaning using liquid solvents and alkaline solutions

Part 2 – power tool cleaning

Part 4 – abrasive blast cleaning

Part 7 – hand tool cleaning of metal surfaces

Part 9 – pictorial surface preparation standards for painting steel surfaces

AS/NZS 4680 Hot-dip galvanised (zinc) coatings on fabricated ferrous articles

AS 1734 Aluminium and aluminium alloys, flat sheet, coiled sheet and plate

CONCRETE

AS 3600 Concrete structures

AS 3610 Form work for Concrete

FASTENERS

AS 1214 Hot dip galvanised coatings on threaded fasteners

AS 1420 ISO metric hexagon socket head cap screws

AS 1421 ISO metric hexagon socket set screws

AS 1427 ISO metric machine screws

TIMBER PRODUCTS

AS 2082 Timber - Hardwood - Visually stress-graded for structural purposes

AS 2754 Adhesive for timber and timber products

Forest and Wood Products Australia – Interim Industry Standard - Recycled Timber – Visually Graded Recycled Decorative Products

SEALANTS

AS 1527 Two-part polysulphide based sealing compounds for the building industry. AS 001543a Sealing compound silicone rubber base (US specification)

PAINTS AND COATINGS

AS 2310 Glossary of paint and painting terms

AS 2312 Guide to the protection of iron and steel against exterior atmospheric corrosion

AS 2700 Colour standards for general purposes

ASTM 03363 Test method for film hardness by pencil

Fabrication, Finishes and Installation

In conformity with the current applicable Australian Standard Code. All materials shall be new, the best of their respective kind and suitable for their purposes. Materials are to be free from corrosion, prime painted and compatible with the final finish, where applicable. Provide all screws, bolts, rivets, pop rivets, plain and countersunk fastenings and washers of a type and material suitable, sufficient and matching in finish and appearance to the components fastened. Unless otherwise specified, comply with the following where applicable.

Properties: Allow for expansion/contraction of materials.

Electrolysis: Provide insulation between dissimilar metals to prevent electrolysis.

Concrete

Concrete for footings shall be of structural quality and free of defect and constructed to Australian Standard Codes for Concrete Reinforcement and Form work. Neat and uniform surrounds where visible.

Aluminium

Aluminium sheet and extruded sections where specified to be used.

Single full sheets are to be used for each sign face, there are to be no joints in sheet unless otherwise shown on drawings.

Timber

Unless otherwise nominated all timber products to be sourced from renewable sources approved by Forestry Stewardship Council Australia. Recycled timber where nominated to be Spotted Gum, Ironbark or approved equivalent hardwood. Graded to RFG1– class 1 durability as per Interim Industry Standard for recycled timber unless otherwise stated. Refer to link below

<http://www.fwpa.com.au/sites/default/files/z>

Timber subject to weather shall be suitably primed or treated with permanent protection unless otherwise stated.

Paint

Paint to be 2 pack Polyurethane and applied in accordance with manufacturer’s recommendations for spray application. Generic or unbranded products shall not be used. Use only branded premium quality lines from Dulux, Altex, or an equivalent alternative to be approved by the Sunshine Coast Project Representative prior to use. All material required for the application of each finish must be manufactured by one approved manufacturer and used in conjunction with priming and undercoats produced by that manufacturer as a total coating system. All signs shall be factory painted using sprayed finishes or other approved finishes. Surfaces to be satin finish (20 to 50 degree gloss level), with full and even cover. Where screws bolts or both are applied to prefinished material, retouch to match.

Pre-treatment

All materials subject to corrosion shall be suitably primed or otherwise treated with permanent protection. Undercoats shall be evenly applied to concealed frames and supports prior to assembly. Non corrosive materials are to be preferred in all cases.

The Subcontractor shall ensure that all surfaces are properly prepared and in suitable condition to receive the coating system prior to the first application as follows:

- Un-primed or damage primed steelwork shall be abrasive blasted, or power tool cleaned to near white metal, immediately prior to priming or spot priming
- Primed steelwork shall be brushed down, degreased using white spirit
- Galvanised steelwork scheduled to be paint finished shall be degreased using white spirit, and washed with water
- Concrete and masonry surfaces shall be cleaned of all oil, grease and loose foreign matter, including efflorescence and dirt, prior to the application of any paint finishes
- Aluminium should be lightly abraded using fine emery cloth and mineral turpentine as a lubricant. Surfaces should be cleaned with mineral turpentine, washed thoroughly and dried. As soon as surfaces are thoroughly dry, apply self-etching primer to all surfaces. Fine sanding and painting should follow immediately thereafter.

Mixing and blending

All paints shall be mixed in accordance with manufacturer’s recommendations. Chemically cured coatings shall be blended in exact quantities either by weight or by the use of volume matched containers. Accurate and properly calibrated equipment is required capable of weighing to an accuracy of 5g. The whole contents of volume matched containers shall be blended at once. On no account shall part only of volume matched containers be blended. Each container shall be thoroughly and separately mixed using clean mixing equipment that has not been in contact with the other containers. Blended material shall be poured from mixing container; care being taken not to scrape out materials left adhering to the container. Application shall be carried out within 1 hour of mixing. Thinning shall only be permitted for spray applications or sealing coats and then only with thinners supplied by the finish manufacturer for this purpose.

Powder coatings

Powder coatings to meet performance standard AS3715 (Dulux Alphatec Plus or equal standard) and applied as per manufacturers instructions.

Adhesives

Adhesives must be suitable for their application and applied as per manufacturers instructions. Silicone adhesive is to be Dow Corning, Sikaflex or equal standard. The adhesive must meet the following criteria:

- A one part formulation resistant to UV radiation, aging and weathering
- Capable of withstanding high dynamic stresses
- Very low VOC content and not contain silicone, PVC or acetic acid
- High recovery and elastic with low odour, one-part formulation

Section D – SIGN SPECIFICATIONS

Double sided tape

Double sided adhesive tape is to be 3M brand 4016 or equal.

Vinyl Graphics

Cut from self adhesive vinyl by computer operated flat bed knife cutter.

TYPE - Exterior grade cast vinyl

COLOURS - As noted on the colour reference page. Gloss level to match painted surfaces. Thickness: .08mm to .10mm thickness range
Manufacturer: 3M, Calon or equal standard.

Digital Prints

All digital prints are to conform to the following requirements,

- Final output to accurately reflect supplied artwork
- UV cured inks to be used for digital print applications
- Minimum 200dpi resolution at full size
- Minimum 5 year indoor life, minimum 3 year outdoor life
- Print inks and substrates to suit application ie. internal, external and illuminated requirements as noted on the sign type drawings.
- Overlamine front applied prints with protective satin clear cover to match gloss level of painted surfaces
- Apply spray clear coat over for UV and graffiti protection.
- Ensure all surfaces are cleaned and prepared prior to application of digital print.
- Finished print to be free of any air bubbles, creases or distortions.
- Cast external grade vinyl to be used for external applications.

Protective anti-graffiti coating

CLEAR COAT

All painted faces shall have a final clear coat applied over the face to protect from graffiti. The clear coat shall be consistent and compatible with the paint finish and applied as per manufacturers instructions. All signs with vinyl graphics front applied shall have a final clear coat applied over the face to protect the vinyl from scratching. A clear coat shall consist of four sprayed layers of clear non yellowing two pack polyurethane paint.

OVER LAMINATE

Clear Dupont ‘Tedlar’ SP polyvinyl fluoride film with low gloss finish laminated over full sign panel.

Fixings

Materials subject to anodic reactions must be fixed with suitable hardware to eliminate anodic reactions between dissimilar metals. Fixings must suit design requirements ie. galvanised, zinc coated bolts to fix to galvanised structures.

- Tek-screw type fixings are not permitted where visible.
- Stainless steel fixings to be grade 316 with anti-theft heads as shown on drawings.

Construction standards

GENERALLY

Form graphics items accurately to the specified shapes and surfaces with clean, well defined edges or arises, free from blemishes. The Subcontractor shall be responsible for the quality of all materials and workmanship required to manufacture the signs including the materials and workmanship of any firms or individuals who act on behalf of the Subcontractor and/or suppliers.

CONSTRUCTION STANDARDS

Construction is to be of the highest of industry standards. Where connection or suspensions are made, plates, bolts, angles and screws are to be concealed as much as possible from view unless otherwise detailed. Box frames or tube shall be extruded and prefinished. Spaces, drilled holes and fixings shall be consistent from one sign to another. Screws, adhesives and silicones shall be concealed and or made flush with the surface. Fit components with care. Graphic standards are to be carefully adhered to.

STRUCTURAL SUPPORT

Structural support of signs shall be independent of the existing structure except where specifically fixed to walls, floors or ceilings. For all signs, the Subcontractor is to be responsible for strength and suitability of the structural support and connection of all signs. Where visible plinths are shown on the sign drawings, match details as shown. Internal structure may be amended to suit relevant structural requirements.

CUT OUT SHAPES

Cut out shapes must be accurately laser cut from solid material and hand finished as necessary. Fixing pins to be drilled and tapped into back of each shape, minimum 2 per shape/letter.

FABRICATION

For metals weld lines where visible are to be ground back and polished.

ENGRAVING

Engraving must be accurately pantographed or machined to a constant depth into material, minimum 1mm deep. Cutter diameter to be the smallest possible to minimise internal radii inside letters.

WELDING

All welding and welding equipment shall satisfy the requirement of the appropriate standards for the specified material and conform to SAA code. All visible welds to be neat, ground back and polished.

WARRANTY

The signs shall not show deterioration, fading, crazing, peeling or bond failure for a period not less than (5) years from the date of completion.

Graphics standards

Sign messages are to be created from electronic artwork to faithfully reproduce the shapes and typefaces specified. The graphic layouts shall follow the guidelines outlined in the Sign Type Drawings. If requested, Dot Dash will provide only the graphics shown on the Sign Type Drawings as Adobe Illustrator .ai, .pdf or .eps file format. These will be provided on USB for pick up by the sign maker or sent via e-mail, Hightail or other internet portal. It is the responsibility of the sign maker to ensure that all electronic files are accurately converted and match the SignType Drawings provided in form, size & colour. PDF files provided are to be used as reference. If the Subcontractor finds any text messages or graphics that are not catered for in the Sign Type Drawings, the Subcontractor shall prepare a layout of the message at a minimum 1:10 scale and submit the layout for approval prior to production.

The following rules of graphic quality apply:

1. All lettering shall be true to its letter form in face weight and construction.
2. All graphics are to be electronically, photographically or mechanically reproduced.
3. All colours are as specified in Pantone colour reference system or other specified colour.

TYPEFACE

The font Akzidenz Grotesk shown on the sign type drawings are to be used for all messages, text and numerals except where specifically stated otherwise. No other versions of typefaces will be accepted. It is the responsibility of the sign maker to purchase the font(s) as specified.

PICTOGRAMS AND ARROWS

Only the symbols as shown on the sign type drawings are to be used. No other versions will be accepted.

COLOURS

Colours for all parts and faces are as noted on the drawings. All colours to be approved via the sampling process as noted in section 6.

Installation Standards

SITE CONDITIONS

Site inspections are to be carried out prior to installation to verify locations, confirm all architectural details, mounting conditions and dimensions (refer to Section 1.0 Scope of Work).

GENERAL

All installations to be plumb and level, at the heights indicated, securely mounted with theft-resistant fixings. Locate all signs in the correct position and orientation as indicated on Sign Location Plans.

Work shall be complete with all bolts, rivets and other fittings to adequately transmit the loads and stresses imposed. Where bolting of metal work to concrete is specified, fixings to be of approved masonry anchors of the required size. Proper edge clearances should be observed so there is no risk of possible damage to concrete or structural framing. Packing of fixings is permitted to approved tolerances to level and square installations.

PROPRIETARY SIGNAGE

Unless otherwise specified, install proprietary system components in accordance with the recommendations of their respective manufacturers.

INSPECTIONS

Subcontractor's engineer to site inspect and certify all footings prior to pouring of concrete.

The Coastal Pathway Signage Style Guide has been prepared by Dot Dash Pty Ltd for the Sunshine Coast Council.

Dot Dash Pty Ltd ACN 010 951 443
Telephone +617 3896 6600
Level 5, 371 Queen Street
Brisbane Queensland 4000 Australia