

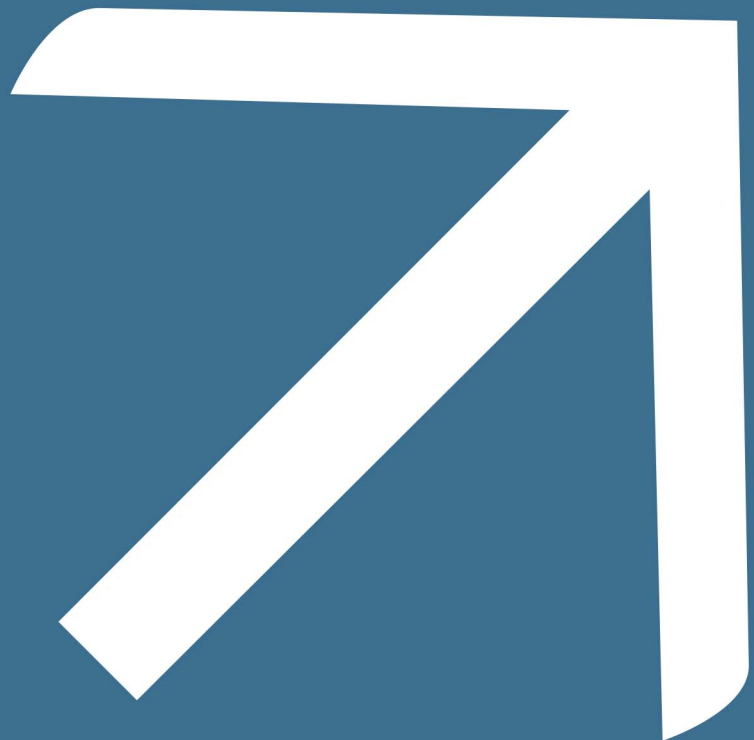

SUNSHINE COAST REGIONAL COUNCIL

Regional Wayfinding Signage Style Guide
RFG 20802

Issue A
9th May 2011



<hr/>	
Acknowledgements	02
Introduction	03
<hr/>	
SECTION A	
WAYFINDING STRATEGY	04
Wayfinding Signage Principles	
Wayfinding Schematic Plan	
<hr/>	
SECTION B	
SITE SUITABILITY	08
Suitability Strategy	
Summary of Signage Suites	
<hr/>	
SECTION C	
MESSAGING STRATEGY	11
Priority Destination Guide	
Message Delivery	
<hr/>	
SECTION D	
GRAPHIC STANDARDS	14
Nomenclature	
Typeface	
Type Detailing	
Pictograms	
Arrows	
Signage Colours	
Map Standards	

<hr/>	
SECTION E	
SIGN SUITE 1	24
Concrete and Aluminium	
1.0 – Sign Suite Summary	
1.1 – Information Map Sign	
1.2 – Directional Blade Sign	
1.3 – Directional Finger Post Sign	
1.4 – Directional Finger Panel only	
<hr/>	
SECTION F	
SIGN SUITE 2	43
Timber and Aluminium	
2.0 – Sign Suite Summary	
2.1 – Information Map Sign Primary	
2.2 – Information Map Sign Secondary	
2.3 – Directional Blade Sign	
2.4 – Directional Finger Post Sign	
2.5 – Directional Finger Panel only	
<hr/>	
SECTION G	
PATHWAY SIGN SUITE 3	66
Pathway Network	
3.0 – Sign Suite Summary	
3.1 – Distance Marker Sign Freestanding	
3.2 – Distance Marker Sign Surface Plate	
3.3 – Distance Marker Sign Stencil	
3.4 – Directional Bollard Sign	
3.5 – Street and Road Direction Sign Stencil	
3.6 – Street and Road Identification Sign Stencil & Surface Plate	
<hr/>	
SECTION H	
ECONOMY SIGN SUITE 4	79
Economy Signs	
4.0 – Sign Suite Summary	
4.1 – Economy Information Map Sign	
4.2 – Economy Information Map Sign with Direction	
4.3 – Economy Directional Finger Post Sign	

<hr/>	
SECTION J	
APPLICATION	97
Preparing a Sign Program	
Sign Location Plan Example	
Sign Schedule Example	
<hr/>	
SECTION K	
MAINTENANCE	101
General Cleaning and Graffiti Removal	
<hr/>	
SECTION L	
SIGN SPECIFICATIONS	103
Codes and Standards	
Quality Management	
Fabrication, Finishes and Installation	
Construction Standards	
Graphic Standards	
Installation Standards	
<hr/>	
APPENDIX A	
Blank Sign Schedule Templates	
APPENDIX B	
Engineer Reports	
APPENDIX C	
Sunshine Coast Regional Council Wayfinding Strategy Report	

The Regional Wayfinding Signage Style Guide has been prepared by Dot Dash Pty Ltd for the Sunshine Coast Regional Council.

The kind assistance of the following people is gratefully acknowledged;

Leigh Abernethy
Place Coordinator - Transport & Engineering
Sunshine Coast Regional Council - Tewantin Office

Russell Higgins
Project Coordinator

Adam Stewart
Project Coordinator

Jamie Franklin
Place Coordinator

Peter Nastrom
Acting Team Leader, Landscape & Urban Design South

Rhys Pollett
Team Leader, Landscape & Urban Design North

The aim of this manual is to outline a region wide wayfinding strategy for town centres and path networks within the Sunshine Coast Regional Council.

The design of the signage system is to ensure wayfinding signs meet quality standards of aesthetic appeal, uniformity and simplicity, while being highly functional in providing the necessary information.

This signage manual provides information on how to design and specify the complete range of sign types required for effective pedestrian and cyclist wayfinding. The manual describes the principles of the wayfinding strategy, details of the various sign types required, followed by visual graphic standards and construction standards.

A range of sign types has been developed for pedestrian and cyclist wayfinding only. Sign types include mapping, directional and regulatory information. This manual does not include signage for town or precinct gateway identification, vehicular traffic control, on-road cycle networks and regional level shared pedestrian and cycle systems such as The Coastal Pathway or Recreation Trail.

This manual is controlled by Place Design and Standards to ensure consistent use when implementing new signage throughout the region. Due to the ongoing development and expansion of town and city centres throughout the region, this manual will be reviewed periodically to maintain accuracy and to capture changing signage needs. Please check with Place Design and Standards to ensure that this manual is current.

It is important that the signage manual be strictly followed to maintain consistency throughout the Sunshine Coast Regional Council. Any questions or special requirements must be referred to Transport & Engineering Management.

We understand and support the SCRC Place Making Charter to develop places for local communities. We see our role as assisting in community understanding, access and enjoyment of these public places through the delivery of well considered information and signage systems.

WAYFINDING STRATEGY



Wayfinding Signage Principles
Wayfinding Schematic Plan

The Sunshine Coast Regional Council wayfinding signage system includes signs for circulation, mapping and identification. The objective of these guidelines is to establish a common visual language, with consistent presentation of information to ensure clarity of communication and simplify visitor circulation and navigation throughout the site.



Information Signs

Information signs will be located at gathering points and pedestrian arrival points within each site. These will identify the site or precinct you have arrived in and provide 'You are here' site maps. These signs will also contain directions and regulations.



Directional Signs

The purpose of these signs is to guide people along a route that leads to their destination. Pedestrian directional signs will provide directions at path intersections. These signs will primarily direct to local facilities, services and Council assets.

Using the principle of progressive disclosure, messages should provide the right information at the right place or time. A directional sign would typically include multiple messages for each direction.

Typical List of Destinations

Council Assets

- National Parks
- Beaches
- Pathways or Trails
- Playgrounds & Parks
- Public Amenities (Toilets, Showers, Baby Change)

Facilities & Services

- Information Centre
- Public Transport (Bus, Train Stations)
- Town Centre or 'High' Street
- Police Station and/or Police Beat
- Hospital
- Post Office

Language

The language of the signs will be in English. Despite the fact that there will be international visitors to the sites, the use of multi-lingual signs is not recommended. The most effective way to communicate in multiple languages is by using pictograms and symbols.

Pictograms and Symbols

Pictograms will be used to identify specific services and facilities. The use of easily recognised international pictograms enables the signs to communicate to a diverse audience, in particular international visitors.

Graphics

The graphic standards are based on achieving high levels of legibility and include:

- high contrast message to background
- maximum size texts for estimated viewing distances
- legible fonts using upper and lower case lettering (sans serif fonts).

Managing Vandalism

The design is mindful of vandalism that may occur in any public place. Vandalism may take place in 3 possible ways:

- physical impact, causing breakage, bending or buckling of sign faces or structures
- mechanical impact, scratching of sign faces
- graffiti, aerosol or marker pen.

While it is impossible to resist the impact of vandalism, the signs have been designed so that repair and replacement are simple and cost effective.

Removal of Old Signs

The signage system described in this manual is intended to replace any existing wayfinding signs. Having two different sign systems in the same environment will compromise effective wayfinding. It is therefore important to remove all previous signs once the new signage system has been implemented in an existing site. Signs of heritage and historical significance that need to be retained are exceptions to this rule.

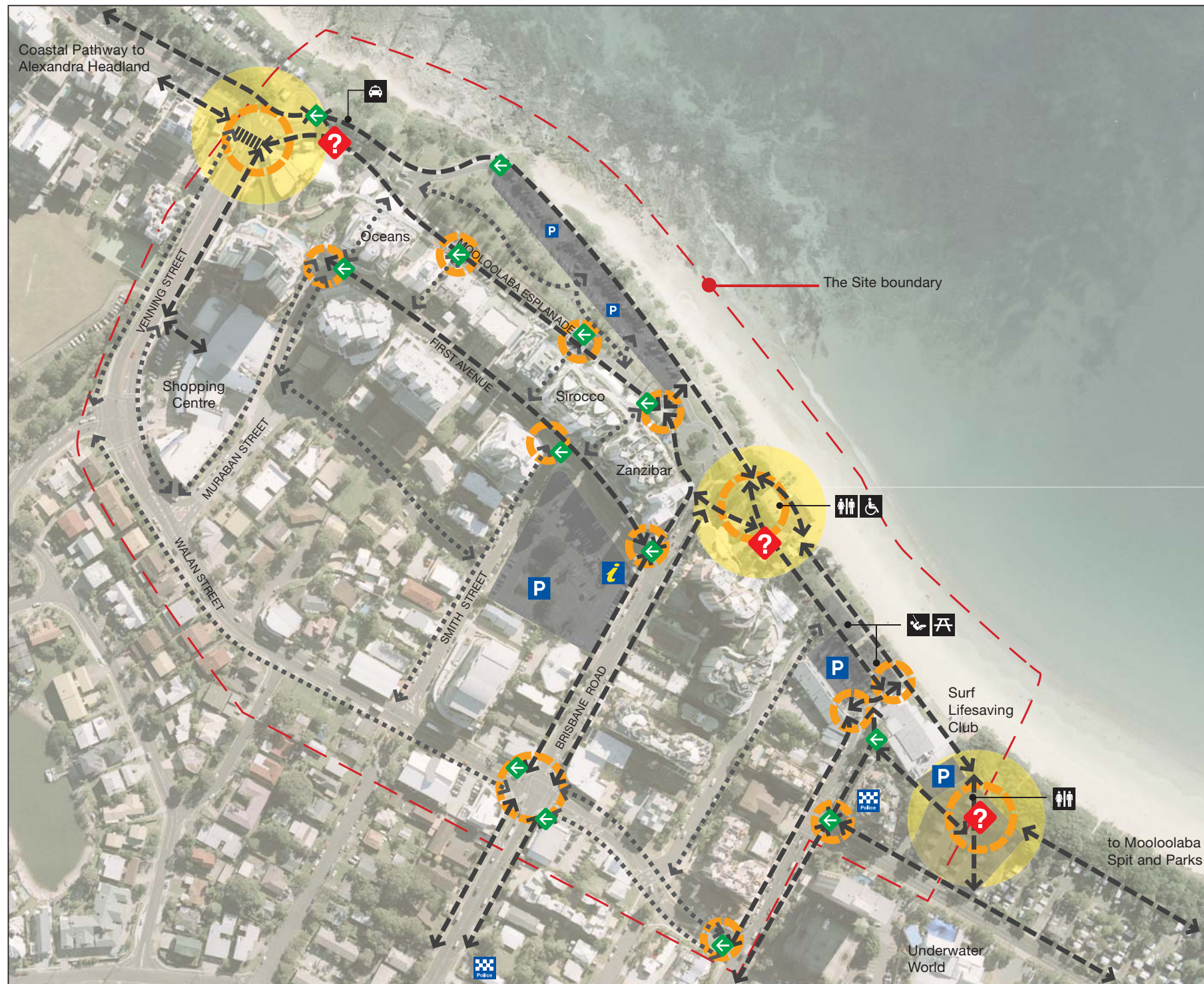

Strategy

The signage strategy should be based on locating signs at decision points on the pedestrian network, specifically at:

- Trip origins – where people join the pedestrian network such as transport interchanges and car parks.
- Pedestrian destinations – where pedestrians need to find their way back or to another destination. Examples include public transport stops, tourist attractions and community facilities.
- Locations where there is possible ambiguity in the route, including major junctions and open areas.
- On long routes where the pedestrian may be uncertain that they have chosen the correct direction and confirmation is required.

The strategy should include signage to all major destinations to which a pedestrian might wish to walk. Once a destination appears on a sign, it must continue to be signed at every subsequent decision point until the destination is reached. Selecting destinations can be contentious so a systematic approach is recommended.

The wayfinding schematic plan illustrates how the principles of the strategy can be applied to a typical site.

Schematic Plan

THE SITE – this site area is studied to identify the arrival and gathering points, and destinations that are unique to each site.

PATHWAYS – each user group is represented as a separate pathway. The pathways indicate where decision points occur. This study should also highlight where the major arrival or gathering points are located.

SIGN TYPES – the sign types are located based on the messaging requirement at each point. These signs are listed in the Summary of Signage Suites in Section B.

<p>Major Public pathways</p>	<p>Non-accessible pathways</p>	<p>Major Arrival Points</p>	<p>Information Signs</p>	<p>Pictograms Indicate existing facilities location</p>
<p>Minor Public pathways</p>		<p>Decision Points</p>	<p>Direction Signs</p>	

SITE SUITABILITY



Suitability Strategy
Summary of Signage Suites

The signage system incorporates a series of suites which have been designed to capture the intrinsic urban and landscape qualities that are unique to the Sunshine Coast and its surrounds.

The common language throughout the suites is the organic shaped sign panels and graphic visual language. Structural elements and forms are the distinguishing components that provide individual characteristics between suites.

Sign Suite 1 & Sign Suite 2

These two suites are considered premium quality and should always be used within the key urban precincts throughout the region's town centres. These are typically the central business districts.

- SIGN SUITE 1 – concrete and aluminium
- SIGN SUITE 2 – timber and aluminium

When selecting a suite, the choice of materials is crucial to delivering a level of quality that will reflect positively on the identity of the area.

Pathway Sign Suite 3

This is a secondary suite that is to be used along the pathway network only. It shall provide:

- identification and direction of pathways
- pedestrian and cyclists distance marking
- direction to surrounding streets
- identify overhead bridges and roadways.

Economy Sign Suite 4

Signage outside of the key urban precincts (i.e. larger CBD areas) will be of an economical grade. This suite has been designed to meet budget and cost considerations and will allow Council to roll out the system further into the community.

Sign types within this suite reflect that of Suites 1 and 2.

Map graphics indicative and shown for illustrative purposes only

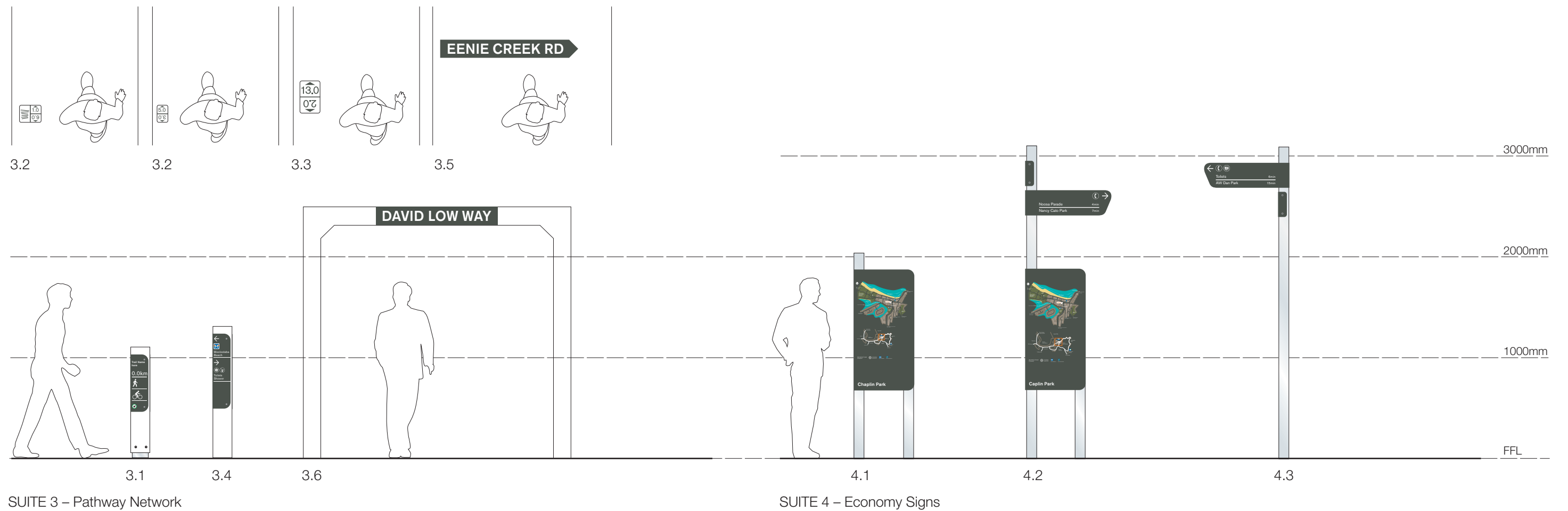
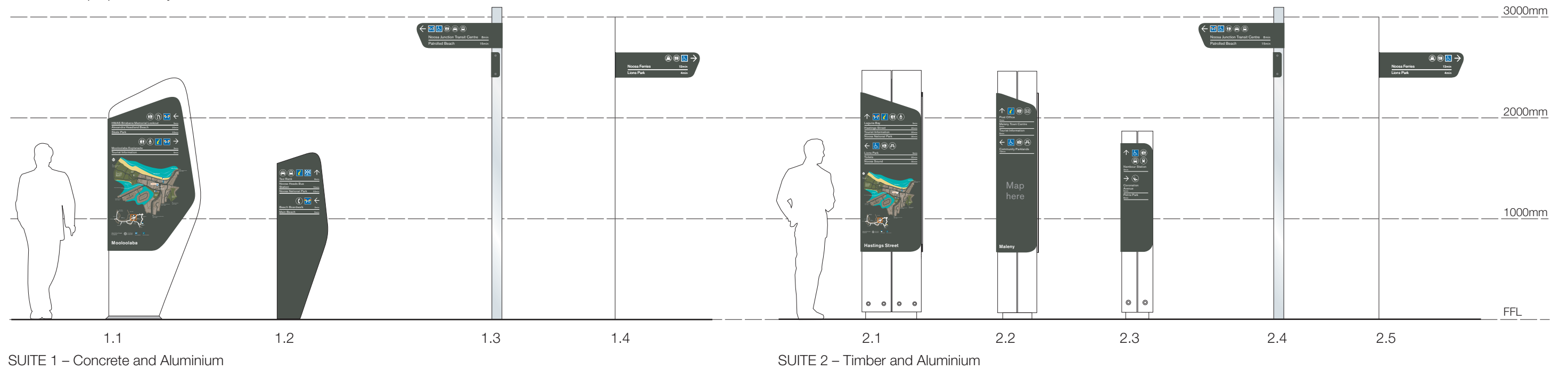

MESSAGING STRATEGY





















Priority Destination Guide
Message Delivery

HIGH PRIORITY	MEDIUM PRIORITY	LOW PRIORITY	For MAPS Only
The most important destinations.	Important destinations.	Less important destinations.	These destinations are good navigational aids and should appear on maps only.
Direct to these destinations on all signs with the site.	Direct to all of these destinations that are located within the general area of the sign location.	Direct to all of these destinations that are located within close proximity of the sign location	
Tourist Information Centre Patrolled Beach National Parks - examples: • Noosa National Park Town Centre or Mall - examples: • Nambour Town Centre Main Street - examples: • Hasting Street • Mooloolaba Esplanade • Bulcock Street	Transport Hubs Taxi Rank Toilets & Baby Change Parks - examples: • Lions Park Coastal Pathway Recreational Trail Police Station Hospital	Public Shower Public Sporting Facilities Telephone Playgrounds BBQ / Picnic Shelters Post Office Library	Car Parks (include time restriction if applicable) Street names Rivers and Creeks

The key objective of the message strategy is to provide a coherent approach that will enable the city and town centres to be appreciated as a totality by the users.

A comprehensive wayfinding system will ensure that users are provided with seamless information that is designed and presented according to their needs at any particular point in their journey.

The table adjacent (left) lists the major destinations, local Council assets, facilities and networks that will be presented. This group is categorised into priority for levels of importance when deciding what messages are to be included at each sign location.

TEXT, PICTOGRAM & TIME	TEXT & TIME Only	PICTOGRAM Only
<p>The name of the destination along with its relative pictogram and pedestrian walking time.</p>	<p>The name of the destination and pedestrian walking time only.</p>	<p>The name of the destination is to be shown by the use of the relative pictogram only.</p>
<div style="display: flex; flex-wrap: wrap; gap: 10px;">     </div> <div style="display: flex; flex-wrap: wrap; gap: 10px; margin-top: 10px;">   </div> <div style="display: flex; flex-wrap: wrap; gap: 10px; margin-top: 10px;">    </div> <p>Tourist Information Centre</p> <p>Patrolled Beach - examples:</p> <ul style="list-style-type: none"> • Main Beach • Mooloolaba Beach <p>Lookouts</p> <p>Transport Hubs</p> <p>Taxi Rank</p> <p>Post Office</p> <p>First Aid / Medical Centre</p> <p>Coastal Pathway (brand symbol)</p>	<p>National Parks - examples:</p> <ul style="list-style-type: none"> • Noosa National Park <p>Town Centre or Mall - examples:</p> <ul style="list-style-type: none"> • Nambour Town Centre <p>Main Street - examples:</p> <ul style="list-style-type: none"> • Hasting Street • Mooloolaba Esplanade • Bulcock Street <p>Parks - examples:</p> <ul style="list-style-type: none"> • Lions Park <p>Recreational Trail</p> <p>Library</p>	<div style="display: flex; flex-wrap: wrap; gap: 10px;">     </div> <div style="display: flex; flex-wrap: wrap; gap: 10px; margin-top: 10px;">     </div> <div style="display: flex; flex-wrap: wrap; gap: 10px; margin-top: 10px;">  </div> <p>Public Toilets & Baby Change</p> <p>Public Shower</p> <p>Telephone</p> <p>Playgrounds</p> <p>BBQ / Picnic Shelters</p> <p>Police Station</p> <p><i>Note</i> When a pictogram destination is the only message on a sign panel, include the relative and text and pedestrian walking time.</p>

Once a destination message has been selected for inclusion on a directional sign it is important to be consistent when applying the message across the sign system.

The table adjacent (left) lists how to apply the message on all direction signs:

- which message are shown with text, pictogram and time
- which messages have text and time only
- which messages are delivered by the use of a pictogram only

It is important to keep as consistent as possible in how a message is applied.

Heirarchy of Destinations

When listing destination names and walking distance time onto a directional sign panel – the following rule applies.

- list the smallest walking time first (i.e. the closest destination to the top, followed by the next closest through to the furthest destination).



GRAPHIC STANDARDS

Nomenclature

Typeface

Type Detailing

Pictograms

Arrows

Signage Colours

Map Standards

Tourist Information

Patrolled Beach

Taxi Rank

Toilets

Telephone

Typical messaging for generic destinations

Noosa National Park

Skate Park

HMAS Brisbane Memorial Lookout

Laguna Lookout

Quota Memorial Park

Always provide the full (correct) name when identifying a specific landmark or destination

Hastings Street

Park Road

Mooloolaba Esplanade

Noosa Junction

Typical location names for Map sign panels

Nomenclature relates to the wording of the signs, as well as the tone of the messages. It is to be applied consistently throughout the Region.

An approved list of all names, destinations and messages has been developed and agreed by all stake holders, and controlled by the Sunshine Coast Regional Council.

This vocabulary needs to be used consistently not only on the signs, but also in all communications and web sites.

Although Sunshine Coast Regional Council's corporate typeface is Arial, the typeface Berthold Akzidenz Grotesk has been selected and approved to be used in all signage within this document.

Typographical qualities of Berthold Akzidenz Grotesk include broad characters, large lowercase x-heights, generous ascenders and descenders, even stroke widths and adequate counter spaces within the bowl of the circular letterforms. These characteristics provide for very good legibility when read on signage within the urban landscape.

Berthold Akzidenz Grotesk Regular

This font is the main variant of the family which should be used on most signs.

Berthold Akzidenz Grotesk Medium

The Medium variant may be used to highlight text. The required information hierarchy has been built into the design of all other signs through use of text and background colour, font size, position and layout.

Regular

ABCDEFGHIJKLMNOPQRSTUVWXYZ

abcdefghijklmnopqrstuvwxyz

1234567890

Berthold Akzidenz Grotesk Regular

Medium

ABCDEFGHIJKLMNOPQRSTUVWXYZ

abcdefghijklmnopqrstuvwxyz

1234567890

Berthold Akzidenz Grotesk Medium

X-height

Cap X-height
The distance between the baseline and the top of an 'X' capital letter

Nambour

Letterspacing (+10)

Bulcock Beach
Noosa Spit Recreational Reserve

Title case

Walk from here.
Pathway leading to beach.

Sentence case

Type Size

Text size on all signs has been determined based on ideal viewing distances and should be adhered to wherever possible. Each sign type drawing has documented the heights which relate to the particular use of each sign. Refer to the sign type drawing for further detail.

Cap X-height

For accuracy in layout of text on signs, the height of the capital letter 'X' should be used instead of the point size of the font. This measurement is always shown in millimetres unless otherwise stated.

Letterspacing

Letterspacing adds space between letterforms to open up text. The addition of minimal letterspacing can increase the legibility, and readability. Added whitespace around the characters allows the individual characters to emerge and be recognized more quickly.

Title Case

Title case is to be used when identifying a destination, facility or locality.

Sentence Case

Sentence case is to be used when not identifying a destination or locality, this in accordance with SCRC Brand Manual (p. 16), Section 3.3.3 Accessibility guidelines.

When uppercase is to be used, this will be specified as part of the design on the relative sign type drawing.



Pictograms and Symbols

Pictograms should be used to identify specific services and facilities. The use of easily recognised international pictograms enables the signs to communicate to a diverse multicultural audience. All pictograms should be supported by English text where possible.

The pictograms are from the suite known as International Symbol Signs System, developed by the American Institute of Graphic Arts (AIGA) and Society of Environmental Graphic Design (SEGD). This suite of pictograms was developed to bring some order to the proliferation of pictograms being used by many different international organisations. This suite has been adopted in many countries and are recognised world wide.

These pictograms are in line with international standards and can generally be understood as stand-alone messages. When used, pictograms should be scaled proportionately.

All pictograms should be used with discretion, as over-use may lead to visual clutter, and confusion.

Pictograms for use on all directional, identification and information signs are as illustrated. The text label shown below each pictogram is used for identification purposes. It should not be used together with the pictogram on a sign.

Safety

If safety pictograms are required, refer to AS 1319 Safety Signs for the Occupational Environment. For clarity, prohibitive pictograms are designed with the red line behind the symbol.

Colour Swatches

- Standard Pictograms
White symbol and stroke on Dulux Woodland Grey
- Tourist Information
PMS 109C symbol on PMS 2945C Background with White stroke
- Accessible
White symbol on PMS 2945C Background with White stroke
- Patrolled Beach
White symbol with PMS 136C and PMS 186C Flags on PMS 2945C Background with White stroke
- Police Station
White symbol on PMS 2945C Background with White stroke
- First Aid / Medical Centre
White symbol on PMS 394C Background with White stroke

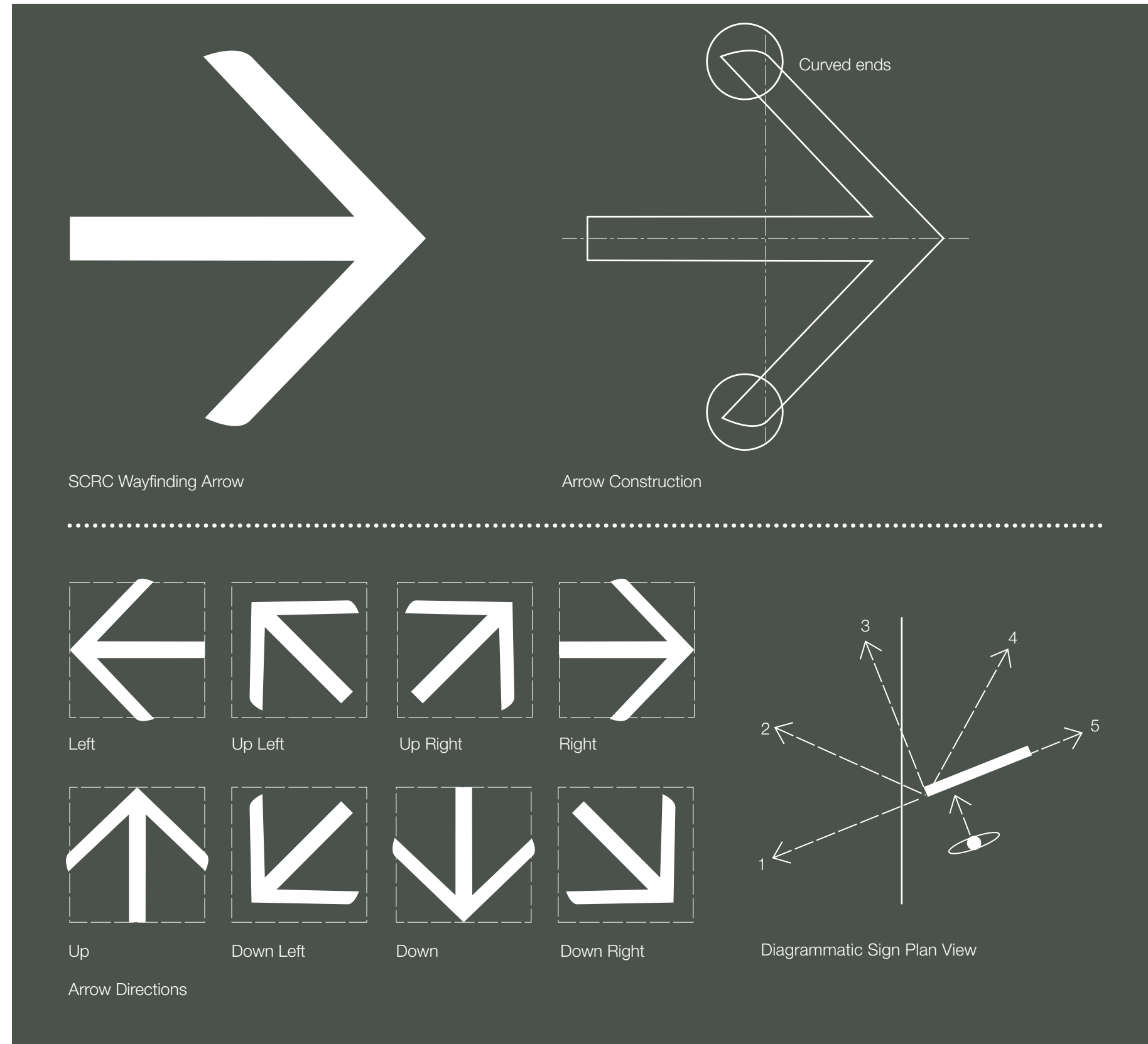

Standard Arrows

Arrows play a major role in wayfinding. To fulfil their purpose in the most effective manner, arrows must be used consistently.

A specific arrow type has been chosen to complement the font Berthold Akzidenz Grotesk. This arrow type should be used in all directional signs.

Arrow Directions

Up pointing arrow is used to direct forward.

Right and Left pointing arrows direct to destinations that require pedestrians to turn right or left, either at the sign or immediately after the sign.

Diagonal arrows direct diagonally up or diagonally down when located next to stairs or ramps. In other locations they direct diagonally ahead. Diagonal arrows may never be used to direct diagonally backwards.

Down pointing arrow should only be used when the sign is above the destination.

Arrow Bounding Box

A square bounding box has been included in these arrow drawings as guides for the correct alignment of arrows and text. Note that the horizontal and vertical arrows extends beyond the box boundaries. After setting arrows and text, when it is no longer required, remember to remove the bounding box from the graphic layout.

Arrow Size

The ratio between the size of the arrow and the text it is associated with must always be maintained. This will be specified as part of the design on the relative sign type drawing.

Arrow Usage

A single arrow is required for each direction, not for each destination.



Sunset
PMS 165C

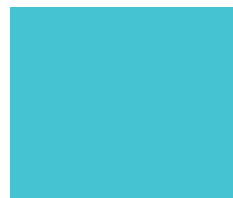

Surf Wash
PMS 3115C



Coastal Blue
PMS 326C



Sand
PMS 458C

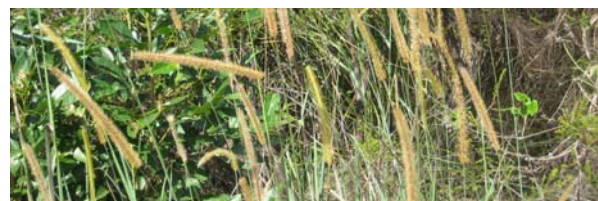

Forest
PMS 5763C



Eucalypt
PMS 403C



Twisted Bark
PMS 404C



Woodland Grey
DULUX Woodland Grey®
PMS 425C

The Coast to Hinterland Palette

The list of colours for this palette represent the richness and diversity of the natural landscape of the Sunshine Coast Regional Council.

- warm and vibrant qualities
- energetic ocean tones
- earthen
- wide varieties of natural fauna
- open eucalypt forest
- deep rainforest
- varied textures and gloss levels

These colours are designed to provide good legibility and contrast when combined, while complimenting each other.

Primary Background Colour

The selected background colour Dulux Woodland Grey® will ensure that the signs are distinctive and easily identified, yet be able to synchronize with the local environment.

This colour is inspired by the depth of the cool green forest, the canopy of eucalyptus, the twisted bark and deep olive green leaves of tea-tree along the coast and the mossy boulders and ferns found in mountain crevices.

Map Standards

Overview

Maps are important elements to assist wayfinding. They provide a visual cue and can provide more detail than directional signs.

Maps on signs should be orientated to suit the direction the viewer is facing. Whereas hand held maps should be North aligned and based on the same design as the fixed maps to maintain consistency.

The map standards are made up of three elements - (1) You Are Here Map, (2) Contextual Map, (3) Legend & Footer. All three elements are to be used together when developing maps for information signs.

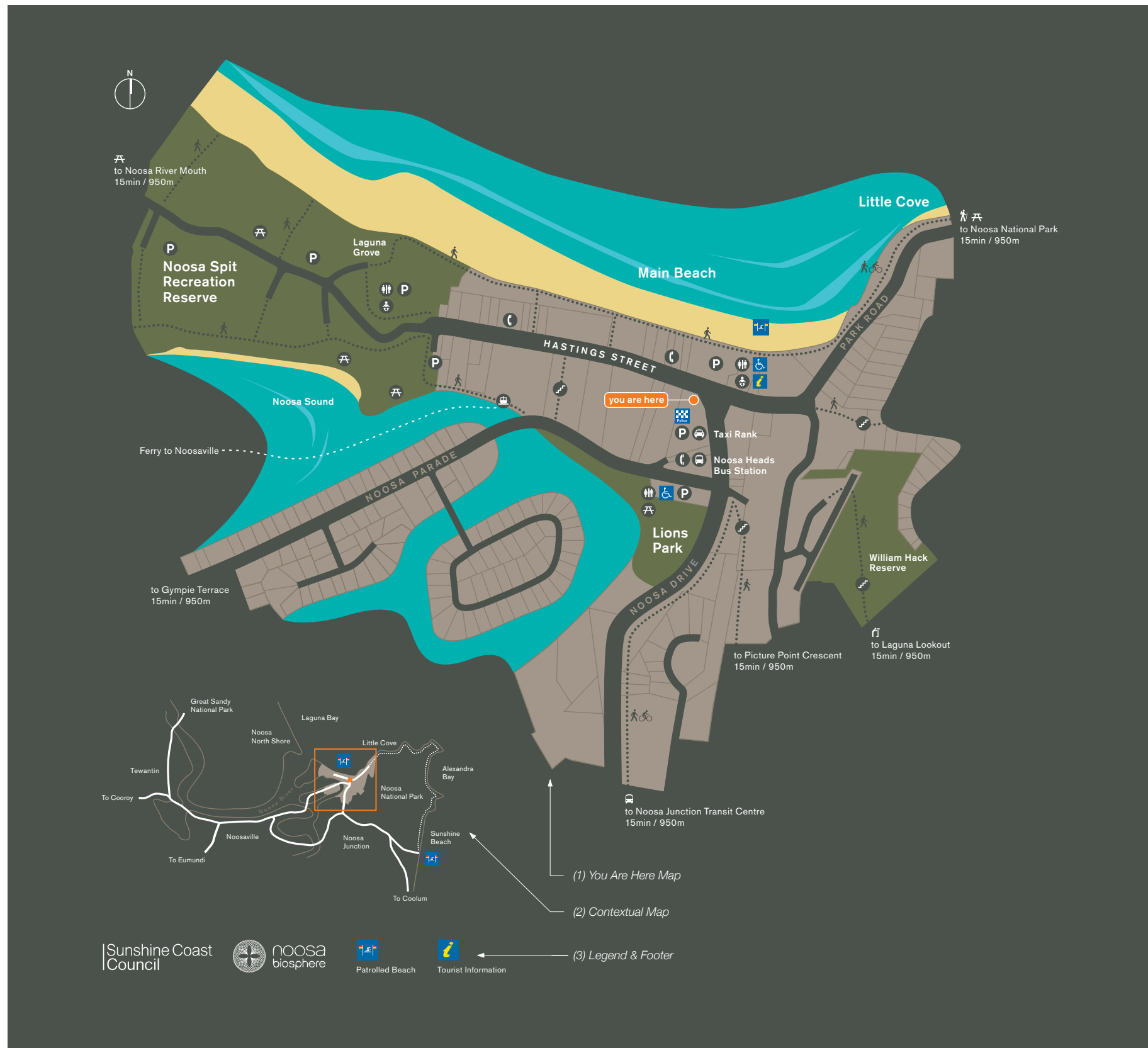

Typical map comprising all three elements

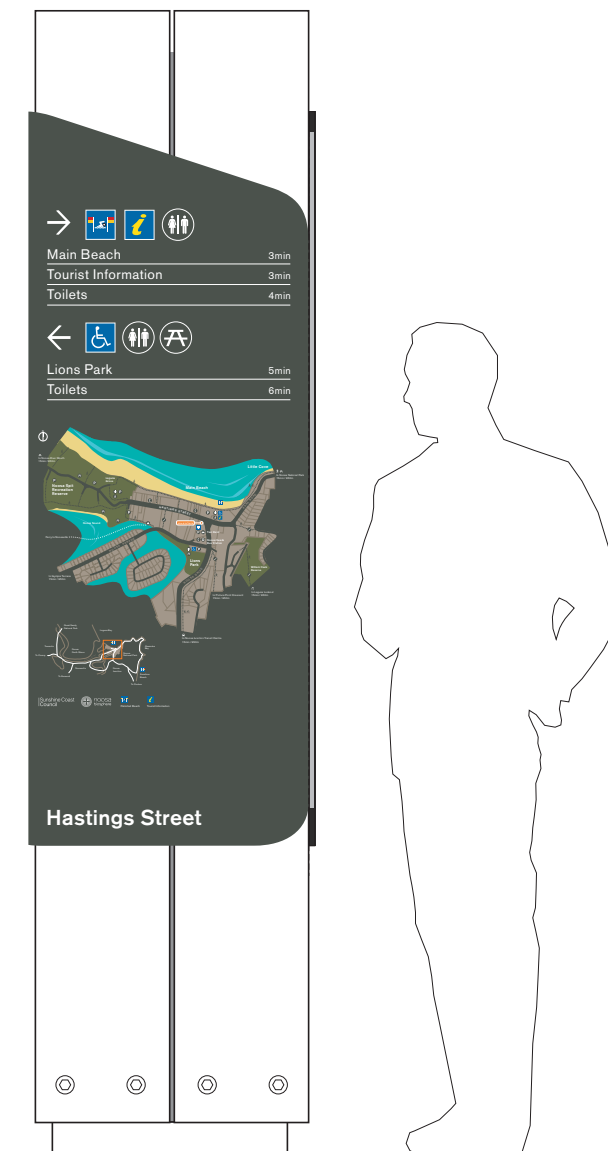

Typical map applied to sign - messages indicative only

Map Standards

You are Here Map

This map is pedestrian focused and is to encompass the geographic area of the key urban precinct within the town or city.

The following is to be shown:









- You are Here locator
- all primary pedestrian/cycle pathways and links
- parks and greenspace
- beach areas along with elements of the ocean
- lakes, rivers and creeks
- primary networks roads and secondary streets and lanes
- building allotment boundaries
- all Council facilities and assets with pictograms
- transport hubs with pictograms and message
- links with distance to destinations outside the geographic area of the map

Typical Sizes

The geographic shape and extent for each key urban precinct across the region will differ, therefore scales of map will also differ. General rule is to select approx 1.0km x 1.2km square area with You are Here approximately located in centre. This area is to be scaled to the approximate width of sign panel. This will provide consistent map scales across the region.

The stroke widths - these should be used as a guide when developing a map at scale 1:1.

Colour Swatches

	You are Here PMS 165C		Park / Greenspace PMS 5763C
	Water Movement PMS 3115C		Land PMS 403C
	Saltwater PMS 326C		Allotment Boundaries PMS 404C
	Sand / Beach PMS 458C		Background / Roads / Pictograms / Pathways DULUX Woodland Grey

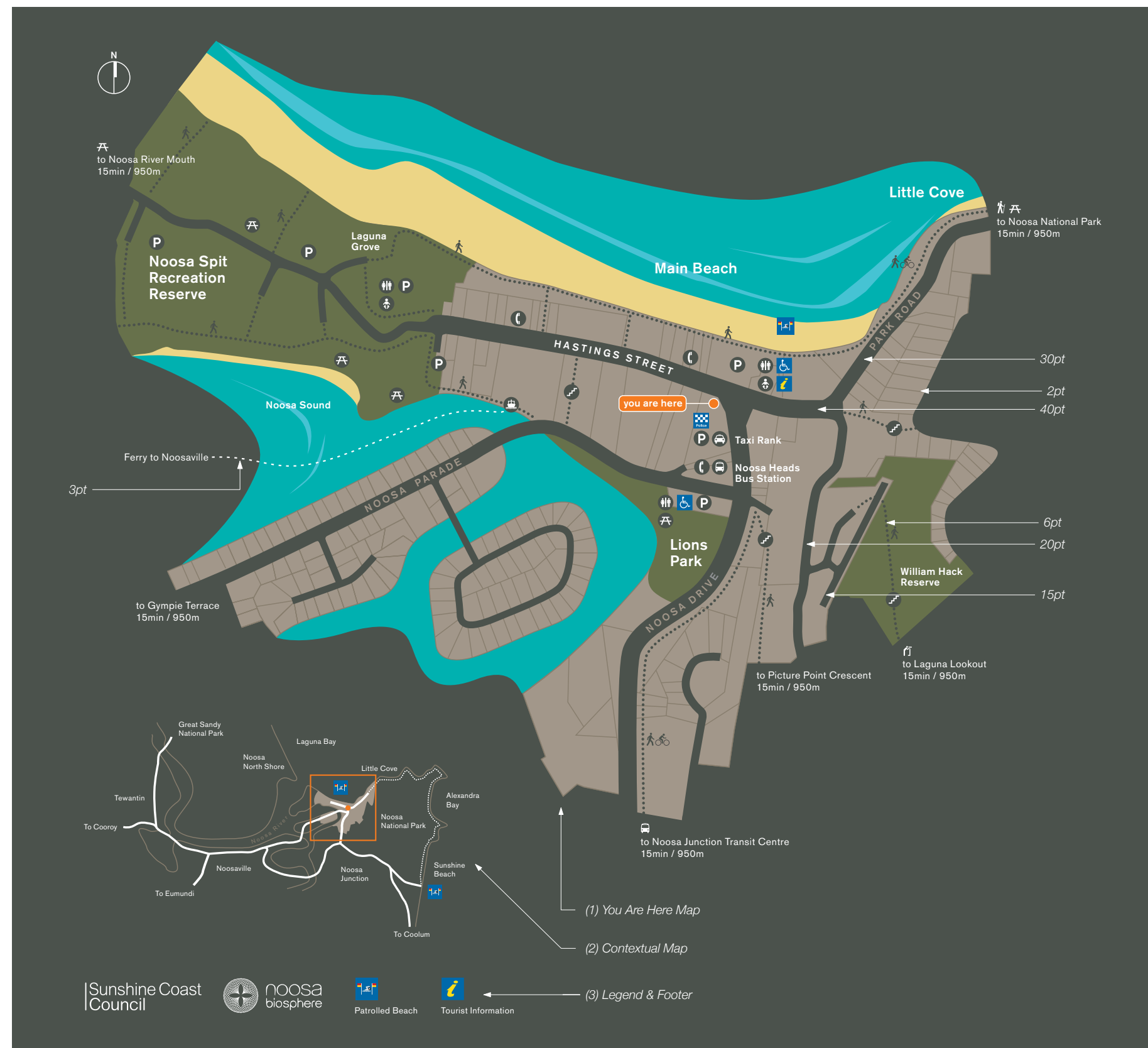

You Are Here Map

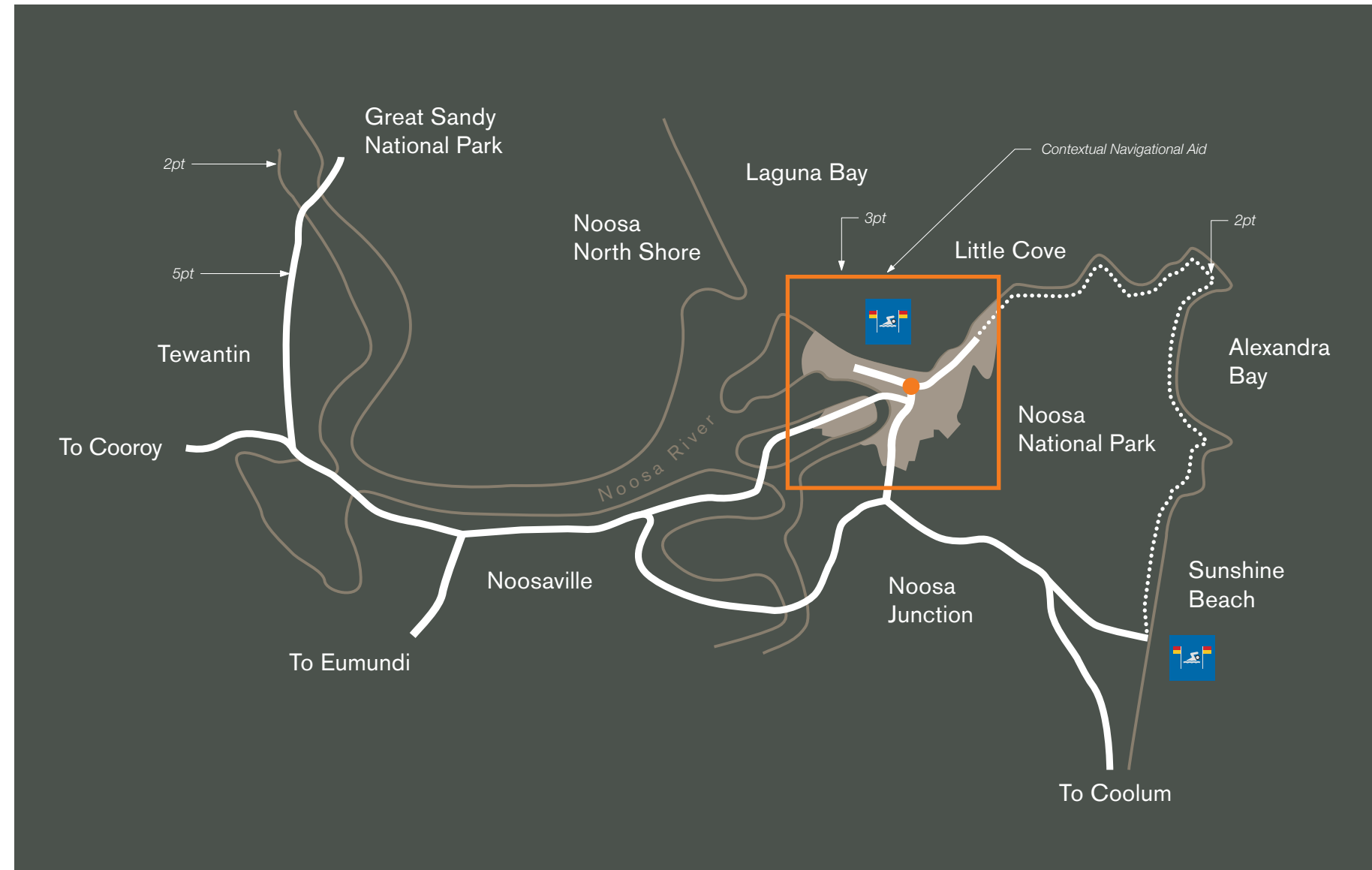

Contextual Map

Contextual Map

This diagram is to support the You are Here map and provide context to the immediate surrounding region. The geographic area of this diagram can be calculated by how far a visitor can access the region in one day typically by foot or cycle.

The Contextual Navigational Aid is to be located approximate to the centre of the map.

The following is to be shown:

- major roads showing links within the region
- major pedestrian pathways (typically through National Parks)
- surrounding towns, cities, National Parks, bays and rivers.
- You are Here located within Contextual Navigational Aid

Colour Swatches

	Contextual Navigational Aid PMS 165C		Land Outline PMS 404C
	Contextual Land Area PMS 403C		Background DULUX Woodland Grey
	Roads / Pathway All Text White		

Legend & Footer

The legend provides branding for the Council and provides the two local key pictograms that need clear identification for visiting tourists. These two pictograms are always to be shown on coastal maps.

This is always to be located below the Contextual Map diagram.

The following is to be shown:

- Sunshine Coast Regional Council logo in White only
- Noosa Biosphere logo in White only
- Patrolled Beach and Tourist Information pictograms with name



Legend & Footer



SUITE 1

Concrete and Aluminium

Sign Suite Summary

Sign Type 1.1 – Information Map Sign

Sign Type 1.2 – Directional Blade Sign

Sign Type 1.3 – Directional Finger Post Sign

Sign Type 1.4 – Directional Finger (Panel only)

SUITE 1 SIGN SUMMARY

- Sign Type 1.1 – Information Map Sign
- Sign Type 1.2 – Directional Blade Sign
- Sign Type 1.3 – Directional Finger Post Sign
- Sign Type 1.4 – Directional Finger (Panel only)

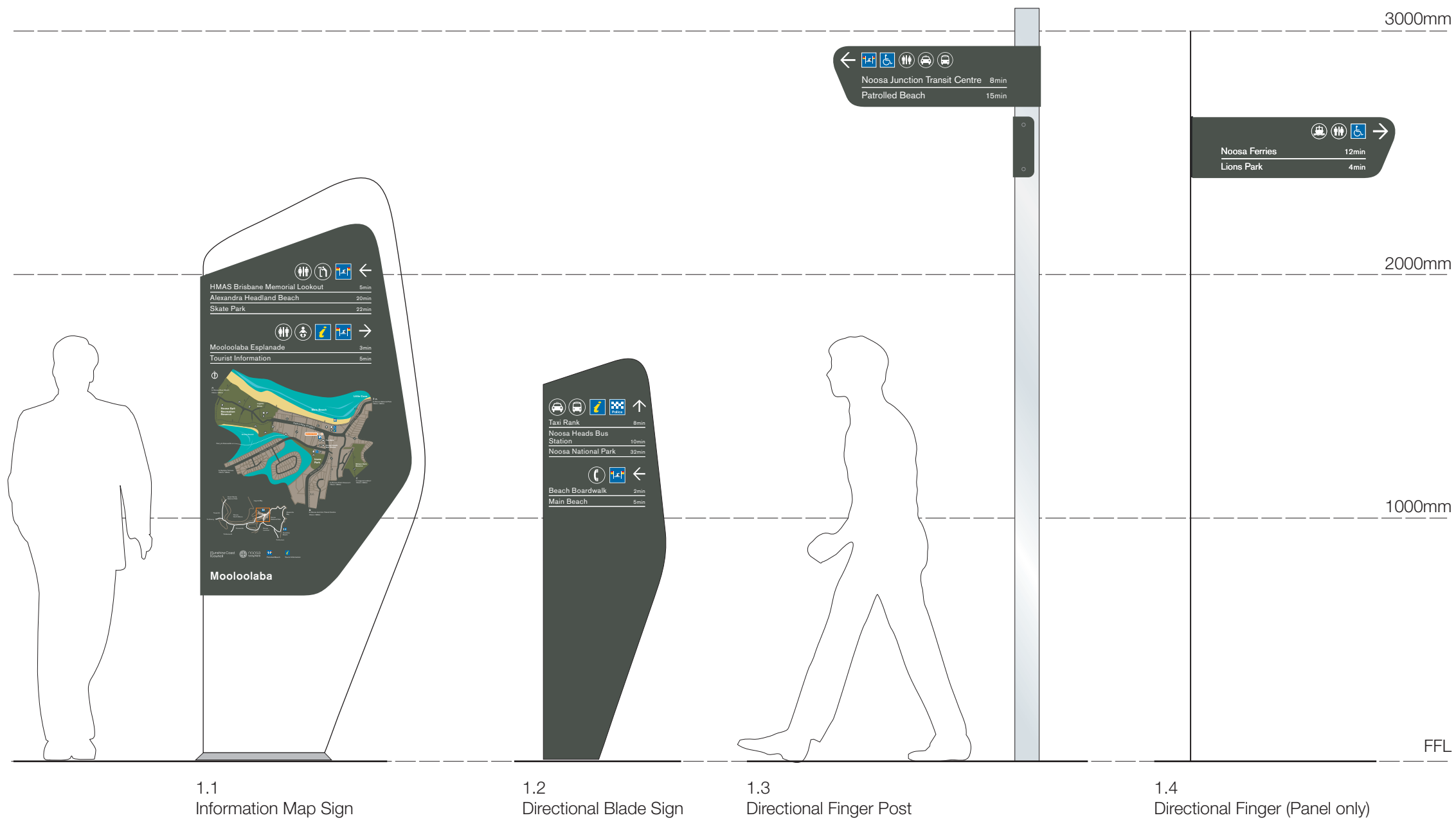

Elevations
Scale 1:20

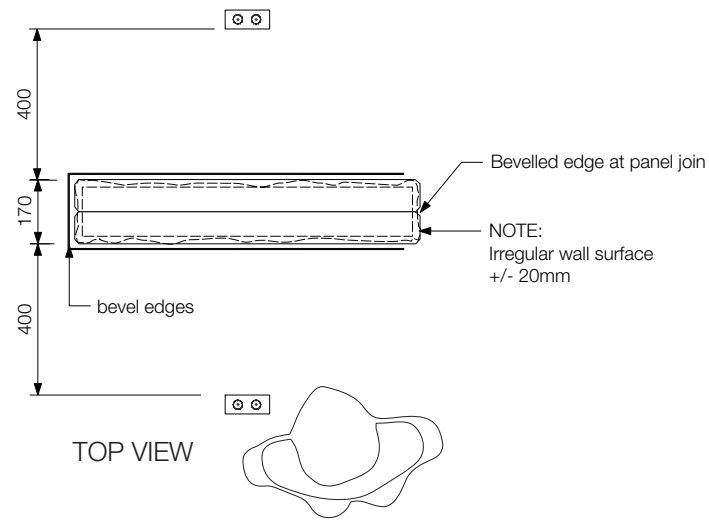

Map graphics indicative and shown for illustrative purposes only

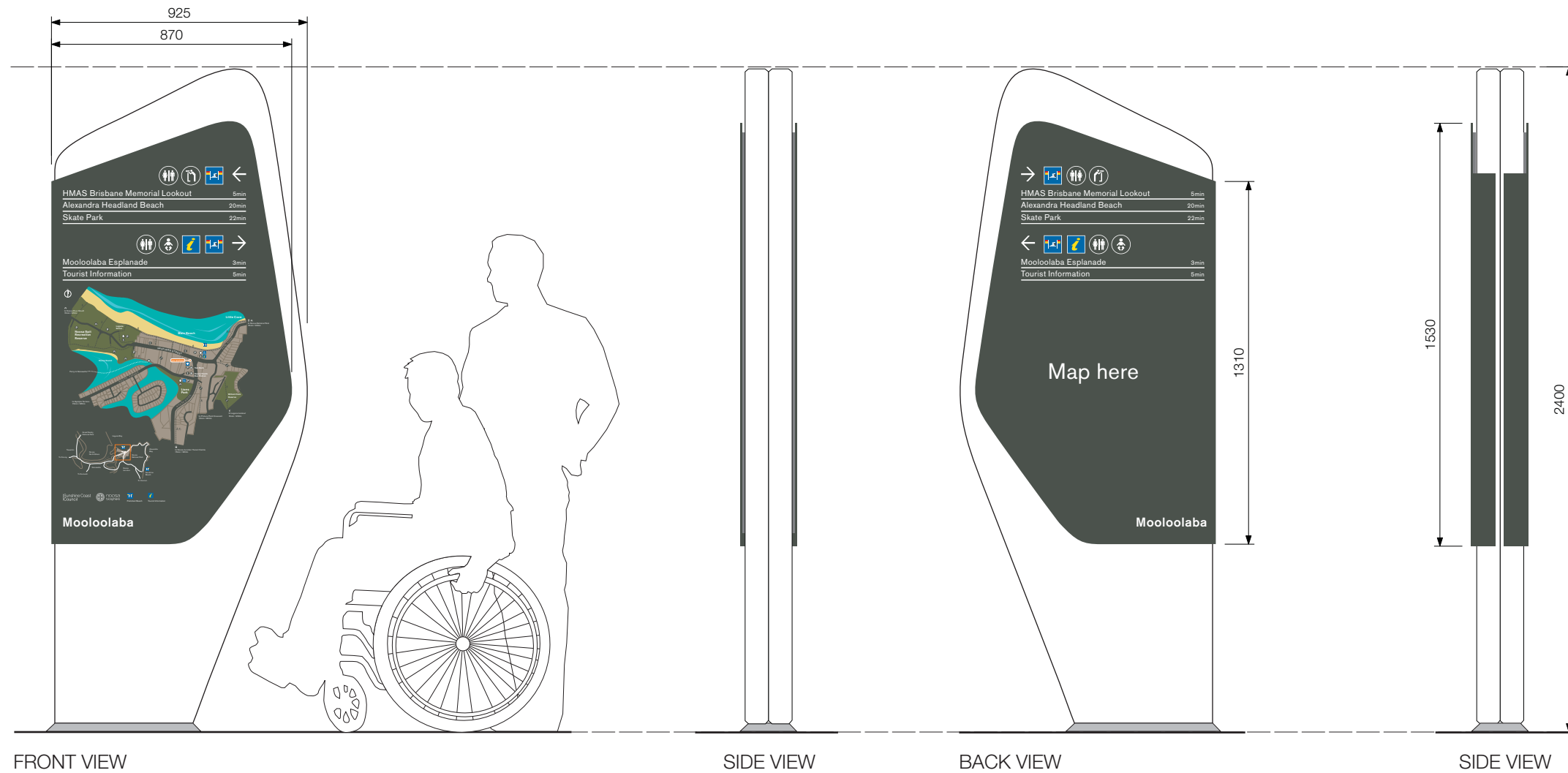

Concrete treatment prototype

GENERAL CONSTRUCTION NOTES

- Refer to sheet 2 for Construction details
- Refer to sheet 3 for Graphic layout details
- Refer to sheet 4 for Structural details

Elevations
 Scale 1:20

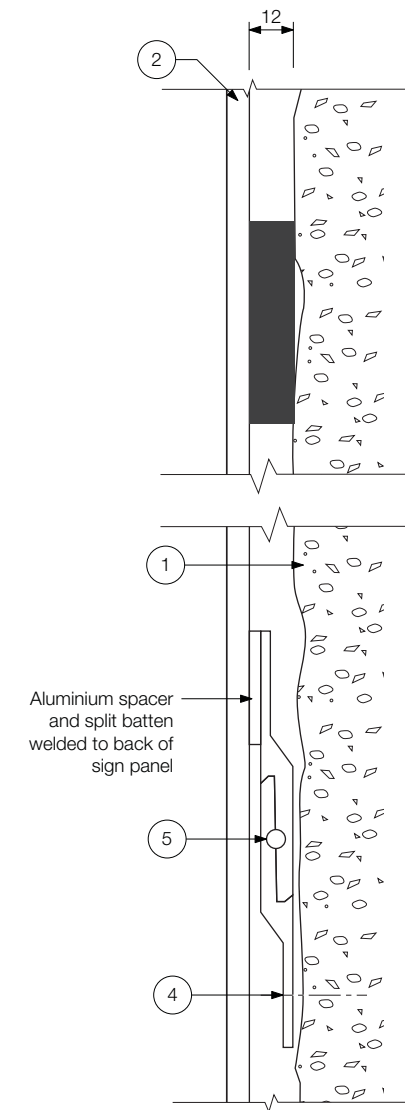
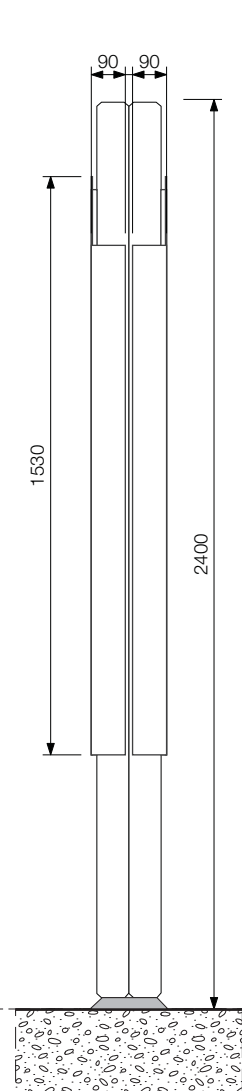
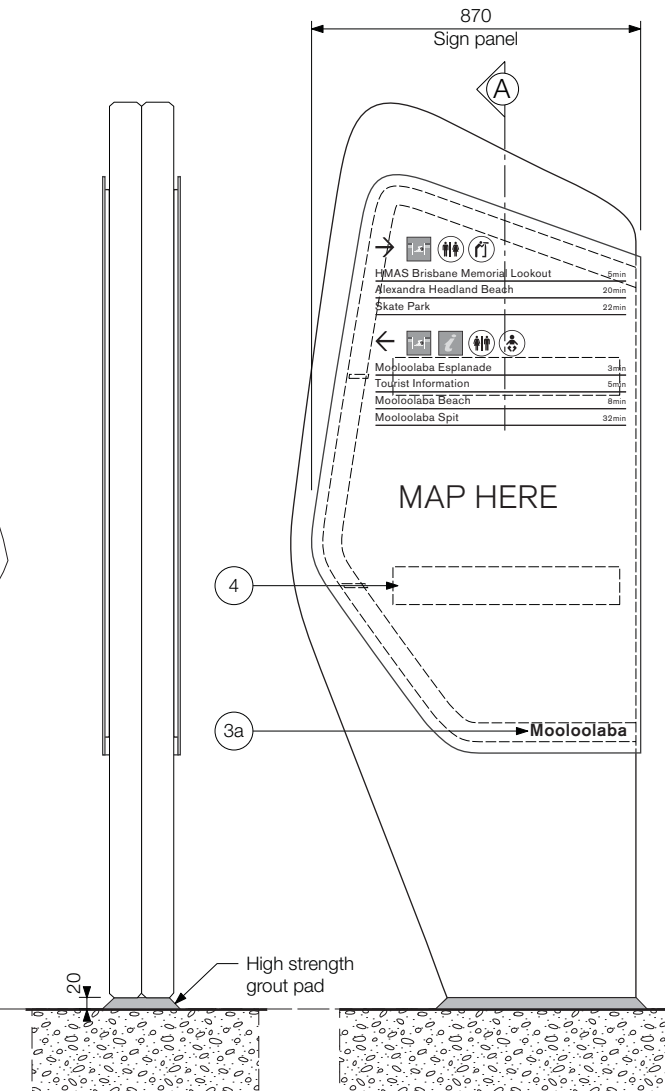
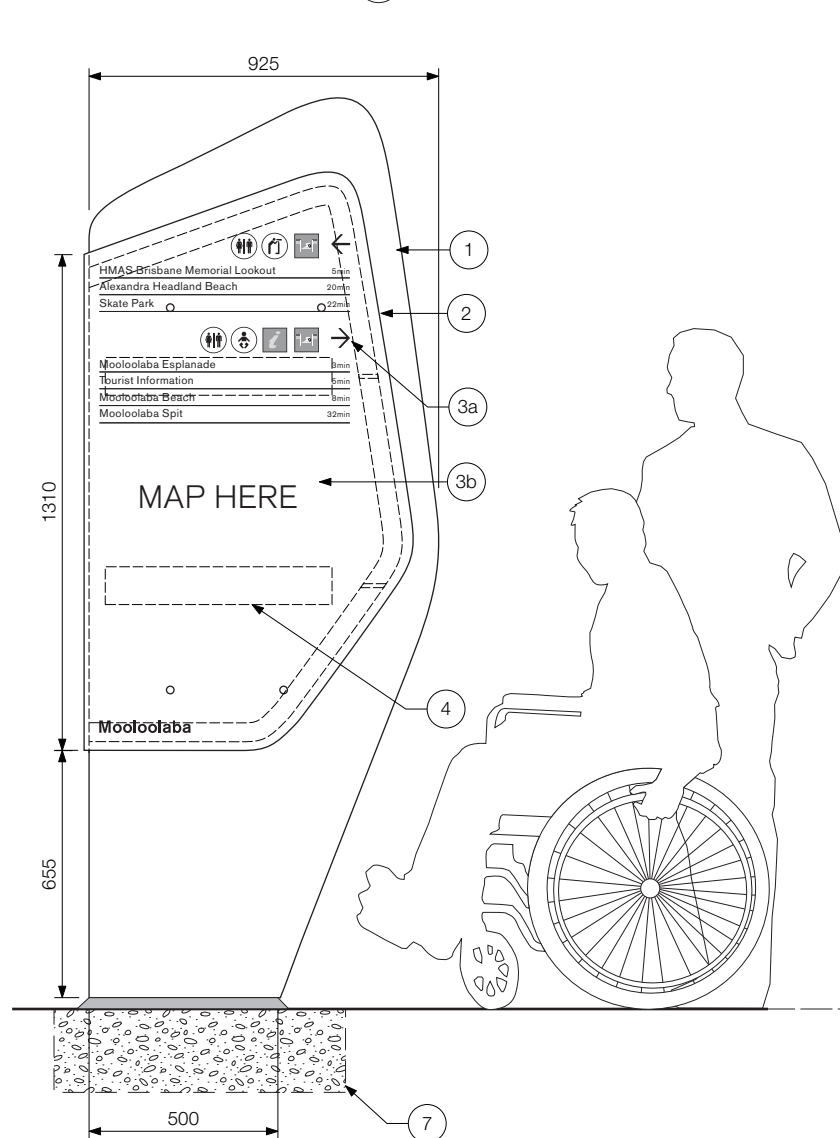
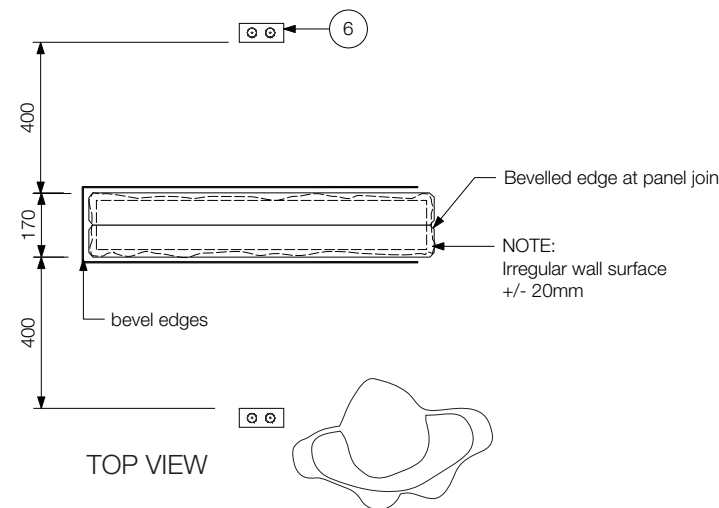

FRONT VIEW

SIDE VIEW

BACK VIEW

SIDE VIEW

Elevations

Scale 1:20

Mounting Detail -Section A

Scale 1:2

GENERAL CONSTRUCTION NOTES

- Refer to sheet 1 for General arrangement
- Refer to sheet 3 for Graphic layout details
- Refer to sheet 4 for Structural details
- Refer to Appendix B for Engineer Specifications
- Drawings show design intent. Any changes to specification which affects design intent must be approved by the SCRC Project Representative.
- Signmaker to confirm all details for approval on shop drawings prior to manufacture.

Construction Details

1. x2 off moulded reinforced pre-cast concrete blade (Class 2 off form) with expressed texture on all exposed faces. Bevelled edge applied to all external edges. Apply matt finish CCS Natural Seal coat over to seal and protect surface. Recessed stainless steel bolts to join panels.

Note - Textured finish, pattern and engineering to be coordinated with SCRC Project Representative.

2. 3mm thick fabricated aluminium sign panel with folded return. 2 pac paint or powdercoat finish to all visible sides anti-graffiti spray clear coat finish all over. 12mm thick painted acrylic backing routed to follow panel profile. Pin fixed to back of sign panel. Slot acrylic spacer to access grub screw fixing.

3a. Directional graphics - front applied vinyl graphics over clear polymeric printed map vinyl.

3b. Map graphics - printed onto clear polymeric vinyl and cut to outer shape of sign panel. Refer sheet 3.

4. Pin and epoxy fix Signlink HD2 split batten aluminium extrusion or approved equivalent to irregular wall finish. Ensure track is spaced off evenly to allow sign face to locate and slide onto tracks.

5. Sign face to mount to split batten and fix to concrete blade via security grub screw fixings.

6. Option A - Inlite (supplier)

'Inlite' Tactic 2 (Deltalight - 213 42 12) ground recessed mounted LED uplights, installed on both sides of sign. Light to wash over both sign faces and concrete blade.

Option B - Lumascape (supplier)

LS393 - LED inground recessed mounted uplights, installed on both sides of sign. Light to wash over both sign faces and concrete blade. Fitting to be provided with 'gimbal' to direct lighting on sign face.

Remote control light gear location to be coordinated with SCRC Project Representative. Refer specification for lighting details.

7. Reinforced concrete footing to engineers specification. All fixings shall be below ground level to reduce trip hazards. Re-instate / make good paving or pavement, with no changes of level greater than 3mm and no gradients steeper than 1:40.

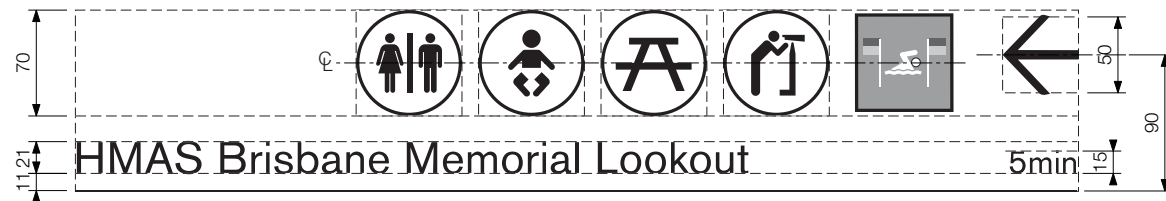

MESSAGE, ARROW & PICTOGRAM

Typical Graphic Detail

Scale 1:5

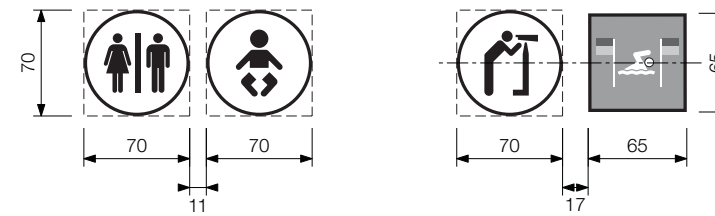

PICTOGRAM RELATIONSHIPS

GENERAL CONSTRUCTION NOTES

- Refer to sheet 1 for General Arrangement details
- Refer to sheet 2 for Construction details
- Refer to sheet 4 for Structural details
- Drawings show design intent. Any changes to specification which affects design intent must be approved by the SCRC Project Representative.
- Signmaker to confirm all details for approval on shop drawings prior to manufacture.

Graphic Production

Directional graphics & Pictograms

Front applied Avery vinyl graphics over clear polymeric printed vinyl.

Map graphics

Full colour, high quality digital print direct to premium clear 5-year polymeric external vinyl. Signmaker to provide manufacturer's warranty. To be printed on flatbed printer.

Clear vinyl to be cut to outer shape of panel and trimmed 3mm from sign panel edge. For folded edge, cut vertical along fold

Print white first and over-print colours to ensure the opacity of the print.

Sign panel to be clear coated with an anti-graffiti 2 pac satin finish. The clear coat shall be consistent and compatible with the paint finish and applied as per manufacturers instructions. Clear coat shall consist of four sprayed layers of clear non yellowing 2 pac polyurethane paint.

Graphic Details

FONT

Directional message = Akzidenz Grotesk Regular
Identification name = Akzidenz Grotesk Medium
Map = Refer Map standards for details

COLOUR

Sign panel background = Dulux Woodland Grey®
Directional message = Avery White
Pictograms - Refer to Pictogram standards for details

Note

Panel finish = Satin finish

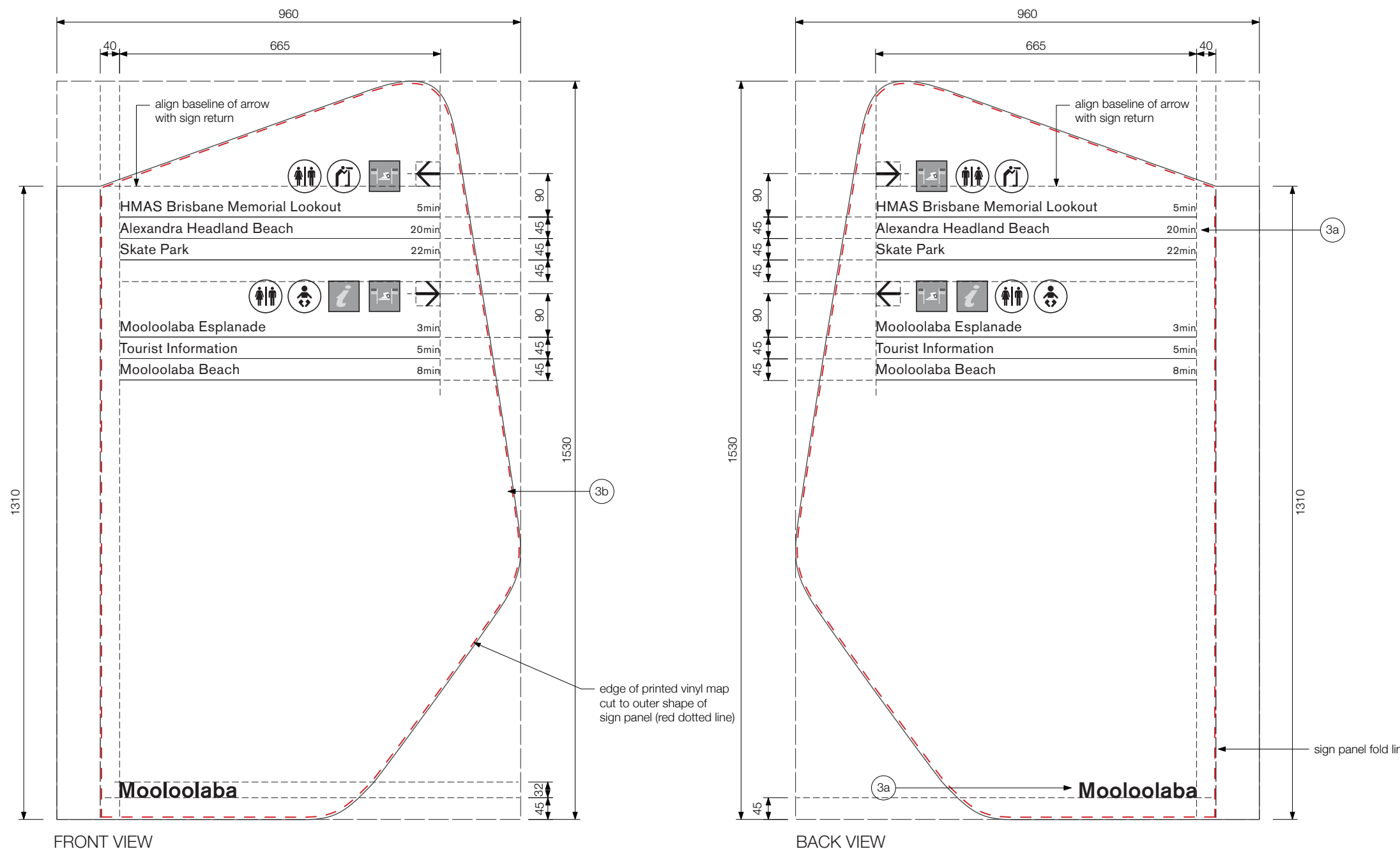

Typical Graphic Layout

Scale 1:10

NOTE
 Panel to be securely removed from its casting bed via wedges before attaching ferrules

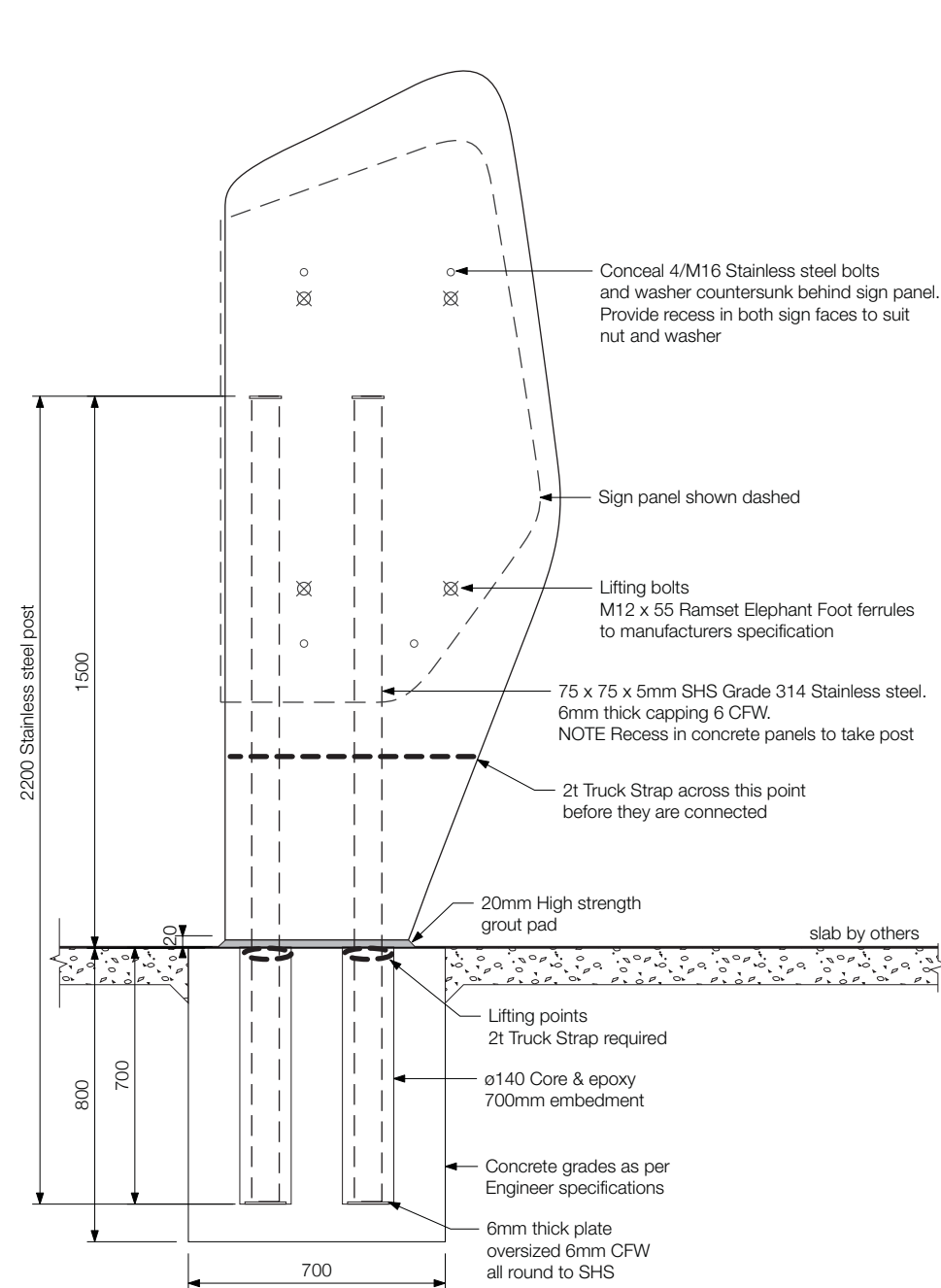

FRONT VIEW

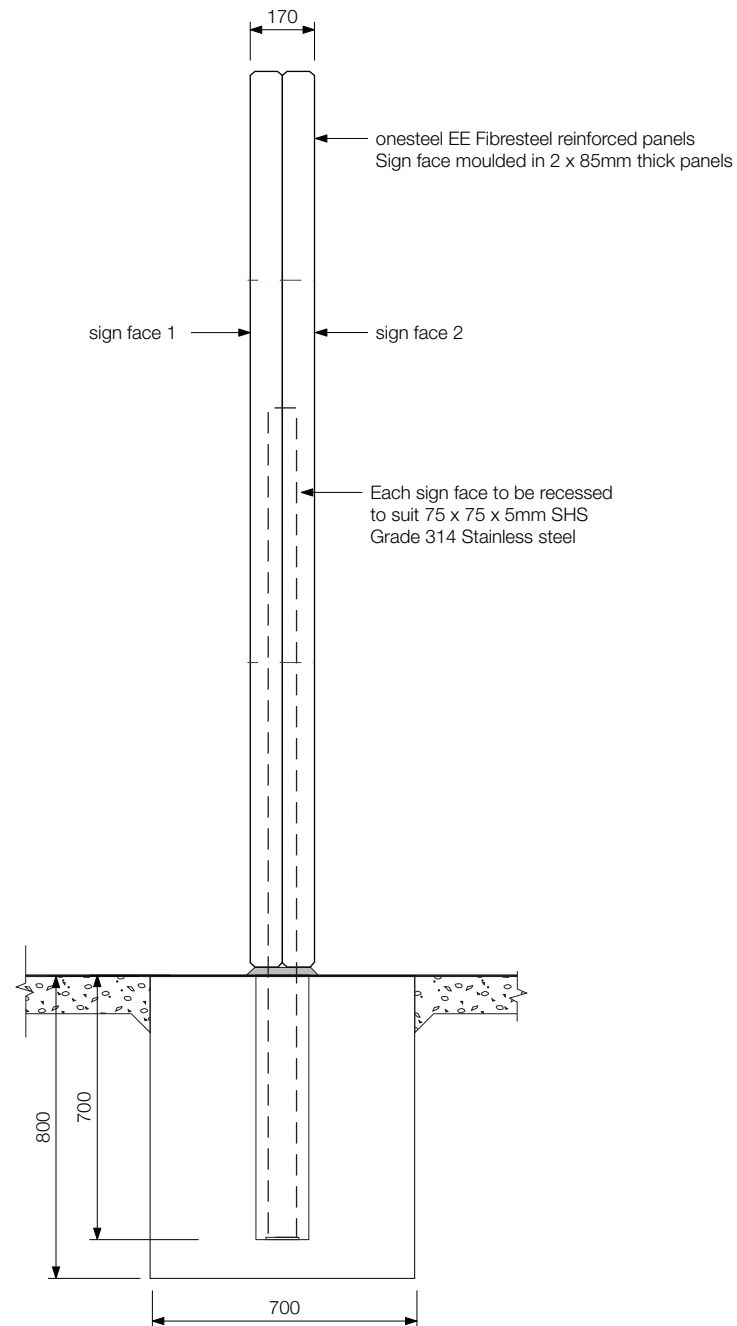

SIDE VIEW

GENERAL CONSTRUCTION NOTES

- Refer to sheet 1 for General Arrangement
- Refer to sheet 2 for Construction details
- Refer to sheet 3 for Graphic details
- Drawings show design intent. Any changes to specification which affects design intent must be approved by the SCRC Project Representative.
- Signmaker to confirm all details for approval on shop drawings prior to manufacture.

Note

- Refer to Appendix B for Engineer's footing details
- Textured finish, pattern and engineering for concrete tilt panel to be coordinated with SCRC Project Representative.
- Concrete finish = CCS Natural Seal Supreme HV to protect concrete from egress of water and salts.

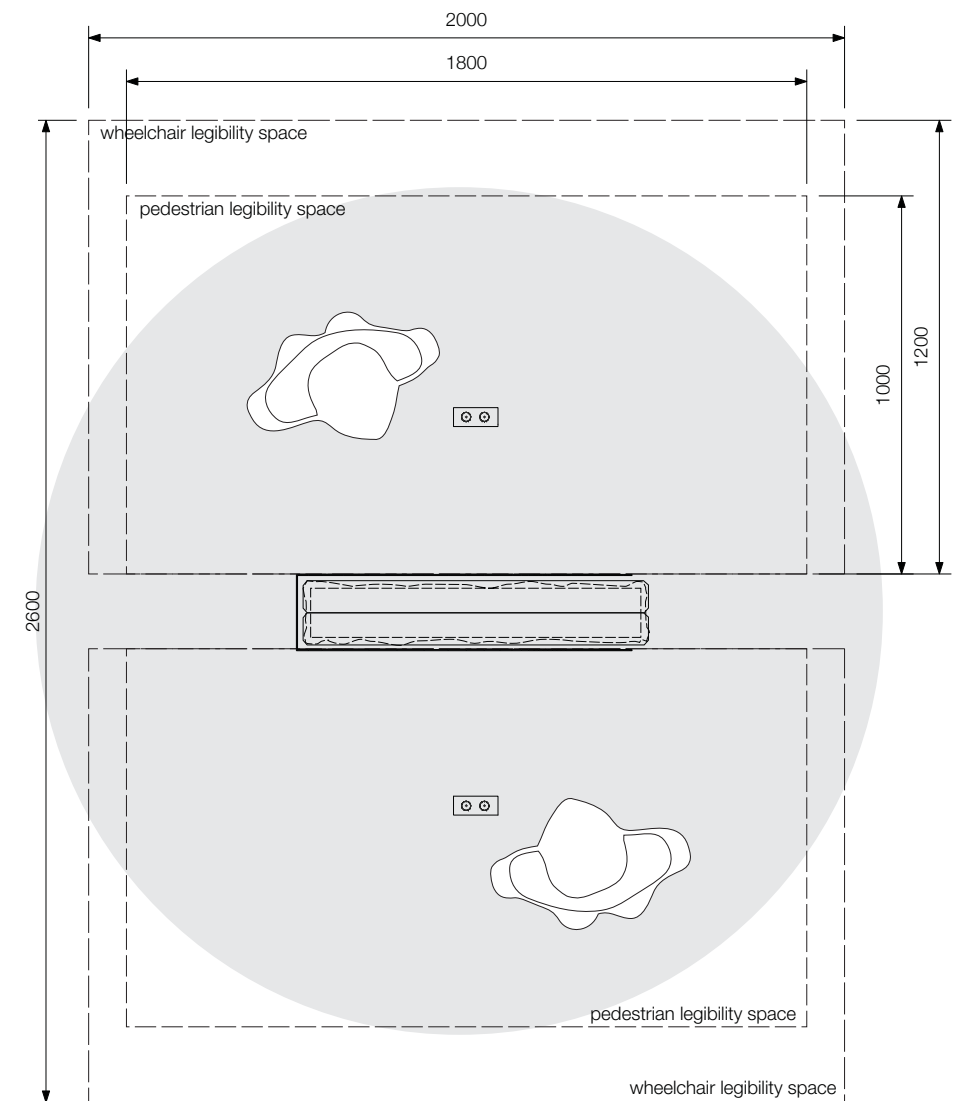

MINIMUM LEGIBILITY SPACE - for viewing map

Elevations

Scale 1:20

GENERAL CONSTRUCTION NOTES

- Refer to sheet 2 for Construction details
- Refer to sheet 3 for Graphic layout details
- Refer to sheet 4 for Structural details

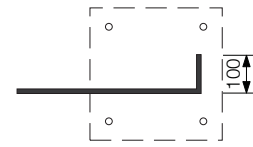

TOP VIEW 1

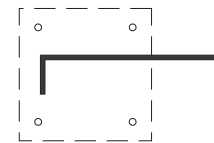
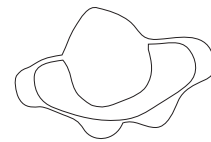

TOP VIEW 2

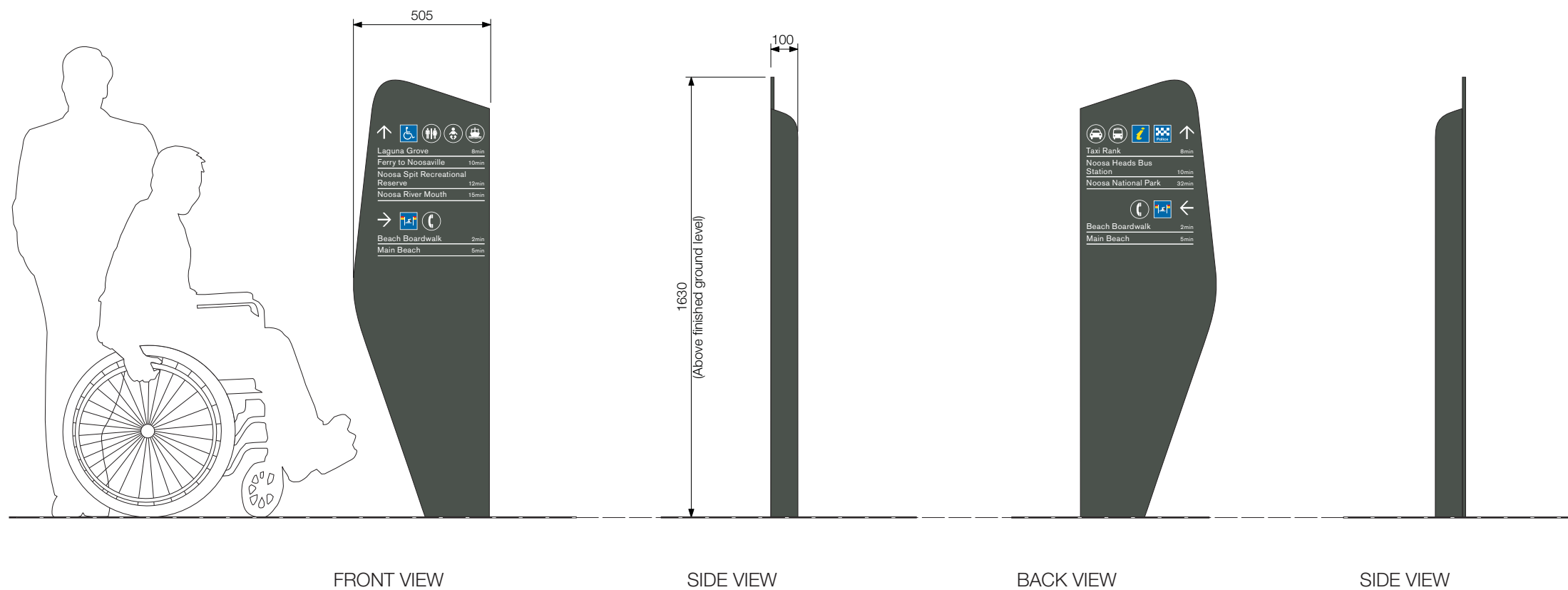
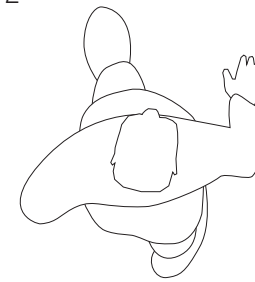

Elevations
 Scale 1:20

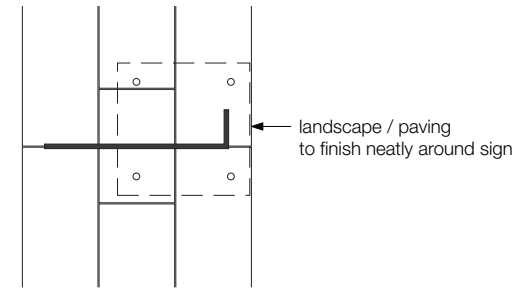

TOP VIEW

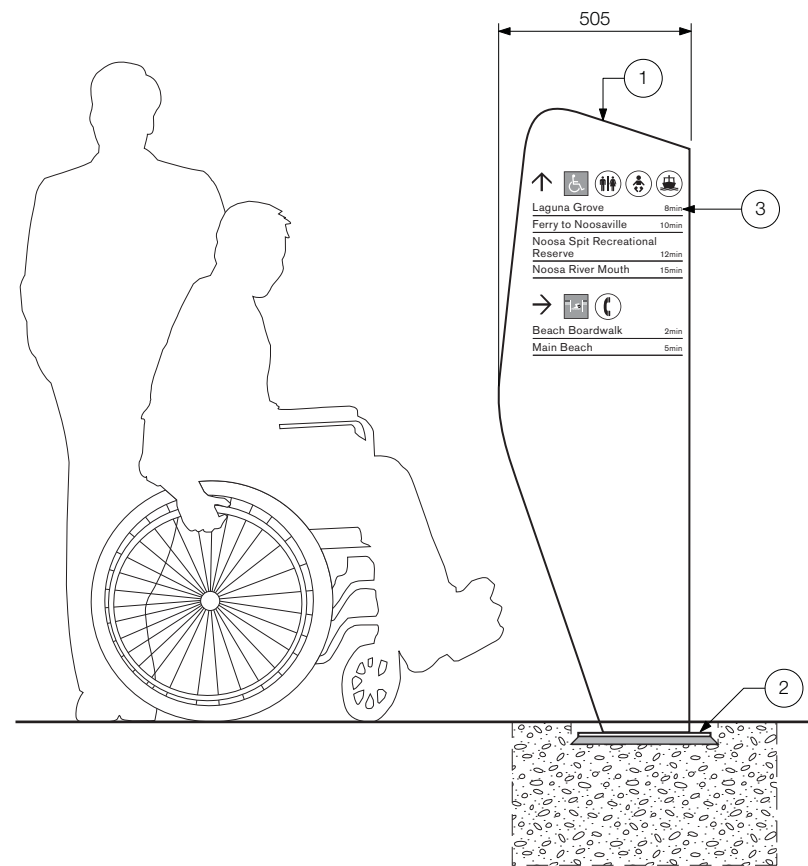
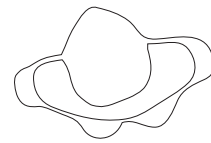

FRONT VIEW

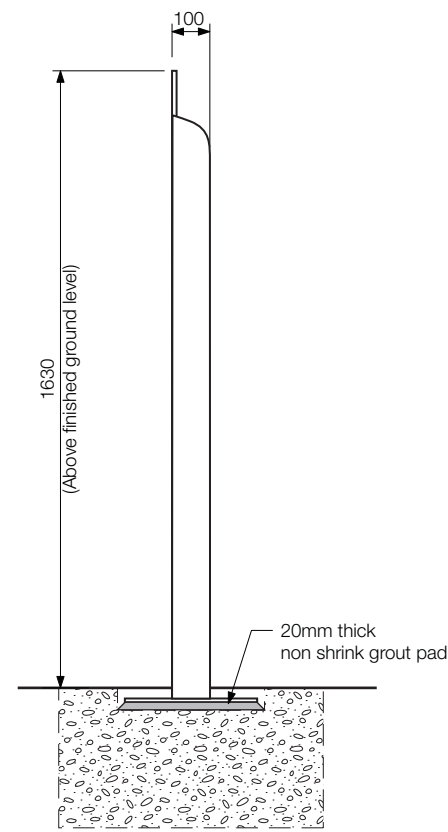

SIDE VIEW

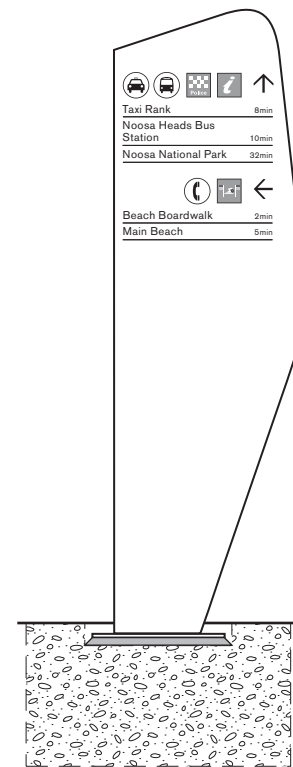

BACK VIEW

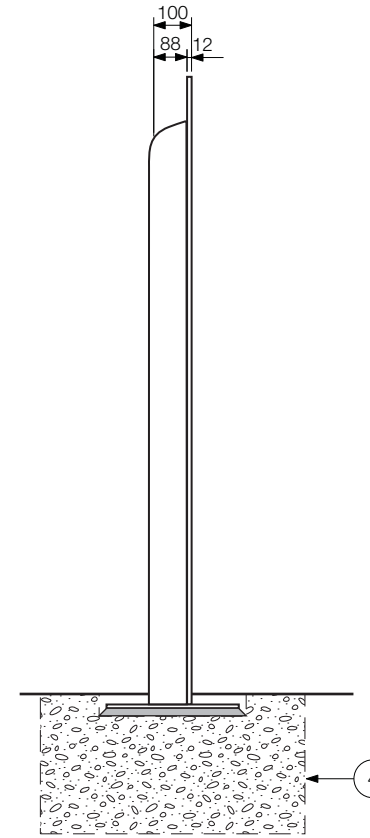

SIDE VIEW

GENERAL CONSTRUCTION NOTES

- Refer to sheet 1 for General arrangement
- Refer to sheet 3 for Graphic layout details
- Refer to sheet 4 for Structural details
- Refer to Appendix B for Engineer Specifications
- Drawings show design intent. Any changes to specification which affects design intent must be approved by the SCRC Project Representative.
- Signmaker to confirm all details for approval on shop drawings prior to manufacture.

Construction Details

1. 12mm thick fabricated steel plate with fully welded return. All welds ground smooth. Sand blast and zinc rich red oxide primer, 2 pac painted or powdercoat to all visible sides, anti-graffiti clear spray coat finish all over.
2. 10mm thick fully welded base plate.
3. Front applied vinyl graphics with 2 pac satin finish, anti-graffiti spray clear coat over.
4. Reinforced concrete pad/pier footing to signmakers' engineer specification. Re-instate / make good paving or pavement, with no changes of level greater than 3mm and no gradients steeper than 1:40.

Material Finish

Panel paint finish = Satin finish

Elevations

Scale 1:20

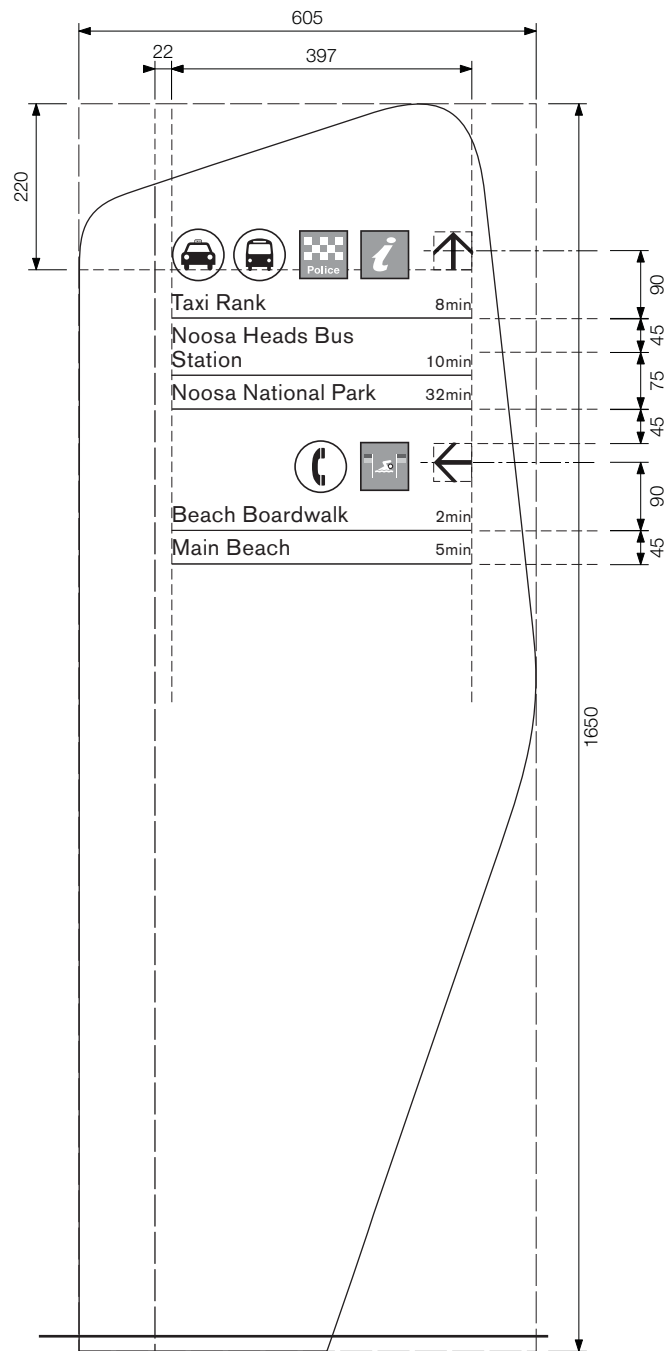

FRONT VIEW

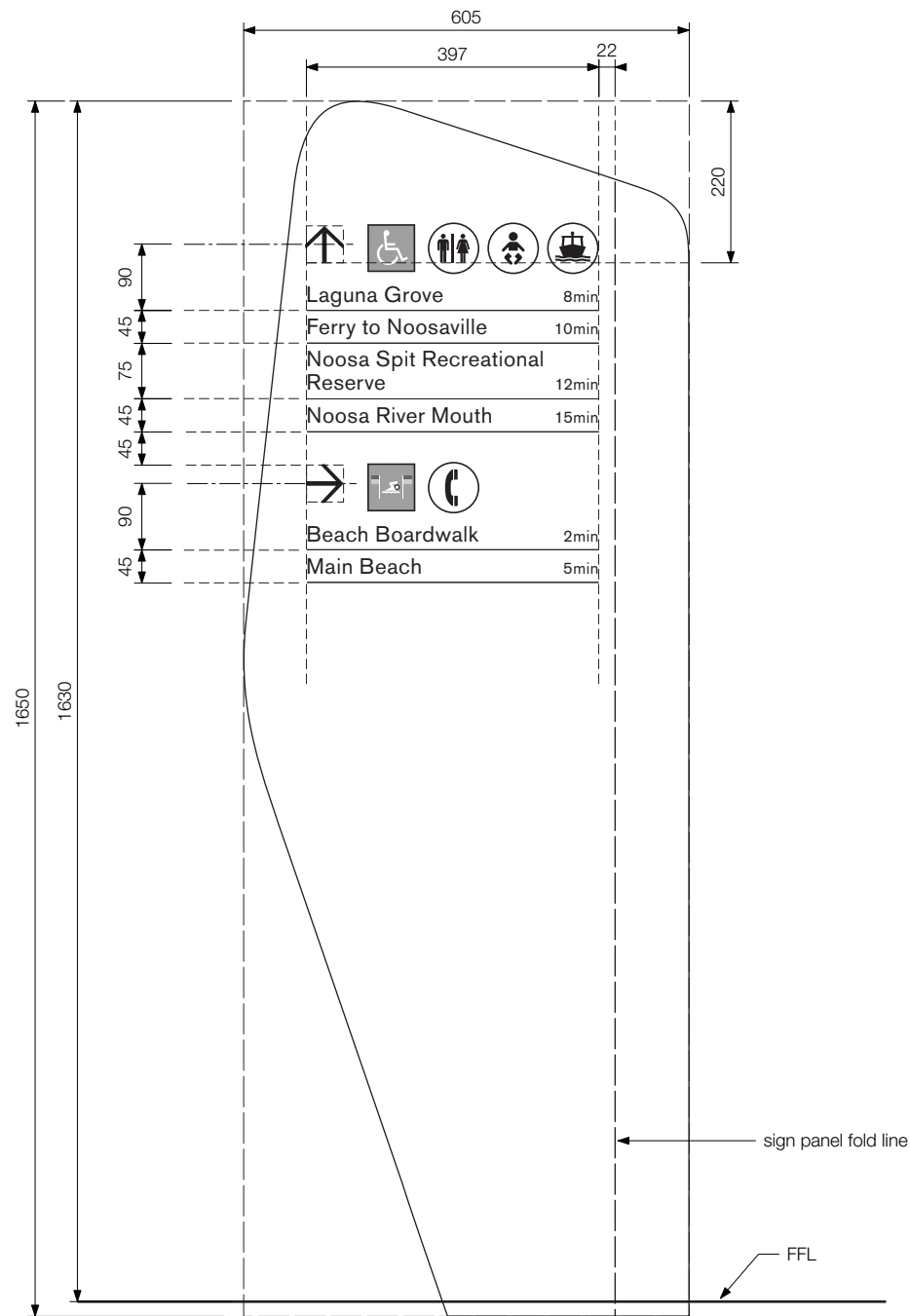

BACK VIEW

GENERAL CONSTRUCTION NOTES

- Refer to sheet 1 for General arrangement
- Refer to sheet 2 for Construction details
- Refer to sheet 4 for Structural details
- Drawings show design intent. Any changes to specification which affects design intent must be approved by the SCRC Project Representative.
- Signmaker to confirm all details for approval on shop drawings prior to manufacture.

Graphic Details

FONT
Message = Berthold Akzidenz Grotesk Regular

COLOUR
Sign panel background = Dulux Woodland Grey®
Directional message = Avery White
Pictograms - Refer to Pictogram standards for details

Note

Panel finish = Satin finish

Typical Graphic Layout
Scale 1:10

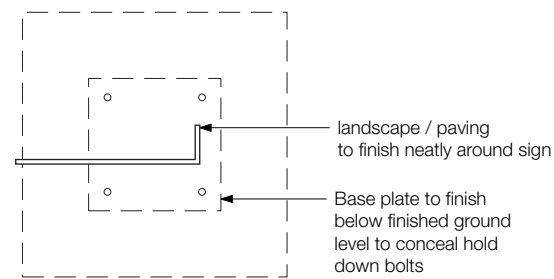

TOP VIEW

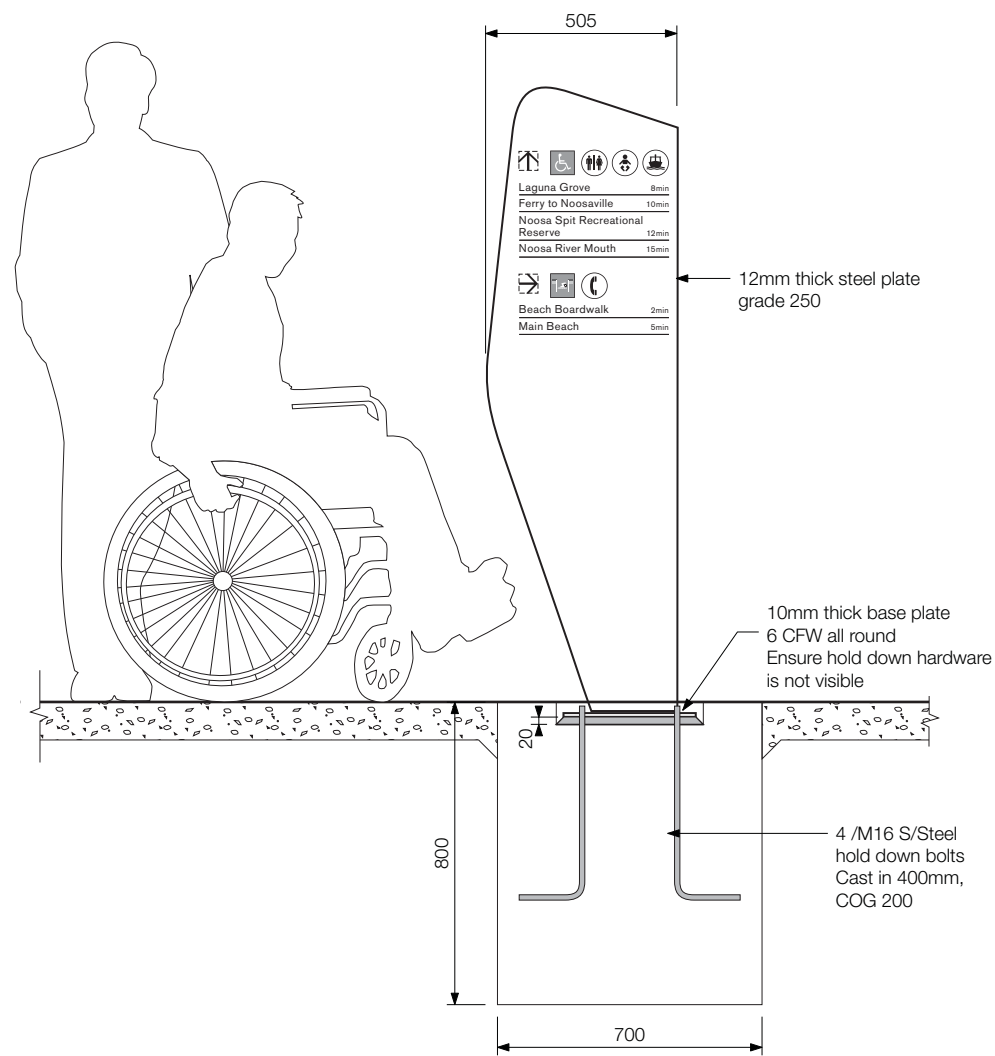
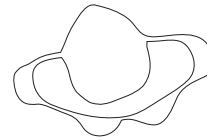

FRONT VIEW

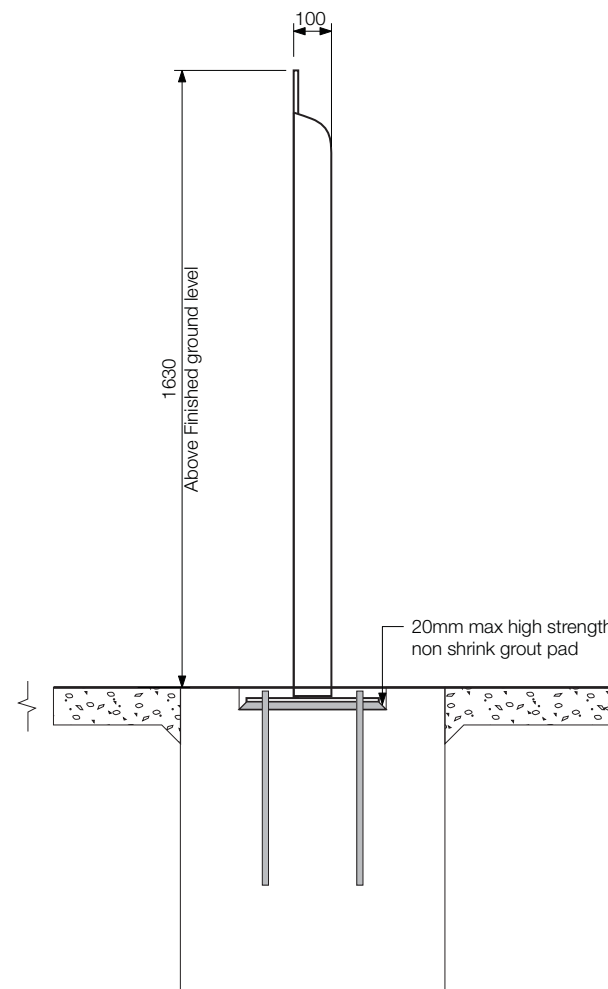

SIDE VIEW

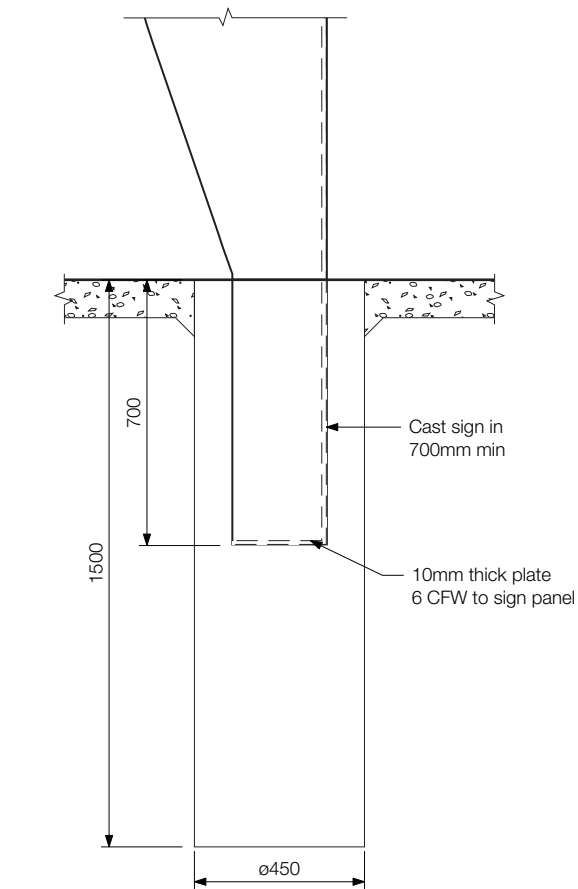

BORED PIER FOOTING - DIRECT EMBEDMENT

GENERAL CONSTRUCTION NOTES

- Refer to sheet 1 for General Arrangement
- Refer to sheet 2 for Construction details
- Refer to sheet 3 for Graphic details
- Refer to Appendix B for Engineer Specifications
- Drawings show design intent. Any changes to specification which affects design intent must be approved by the SCRC Project Representative.
- Signmaker to confirm all details for approval on shop drawings prior to manufacture.

Note

Signmaker's engineer to confirm structural requirement for sign panel.

PAD FOOTING

Elevations

Scale 1:20

GENERAL CONSTRUCTION NOTES

- Refer to sheet 2 for Construction details
- Refer to sheet 3 for Graphic layout details
- Refer to sheet 4 for Above ground install
- Refer to sheet 5 for Direct embed install

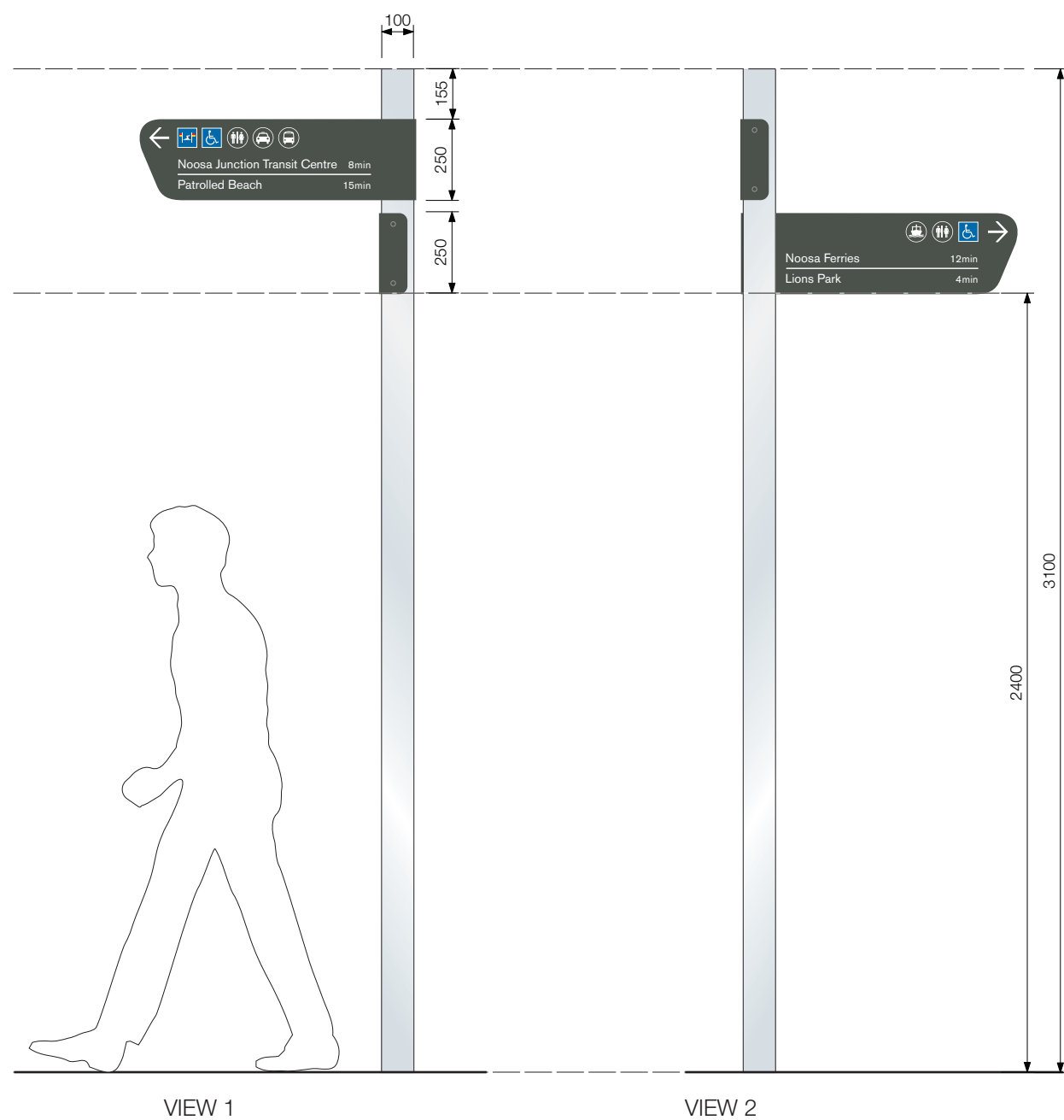

Elevations
 Scale 1:20

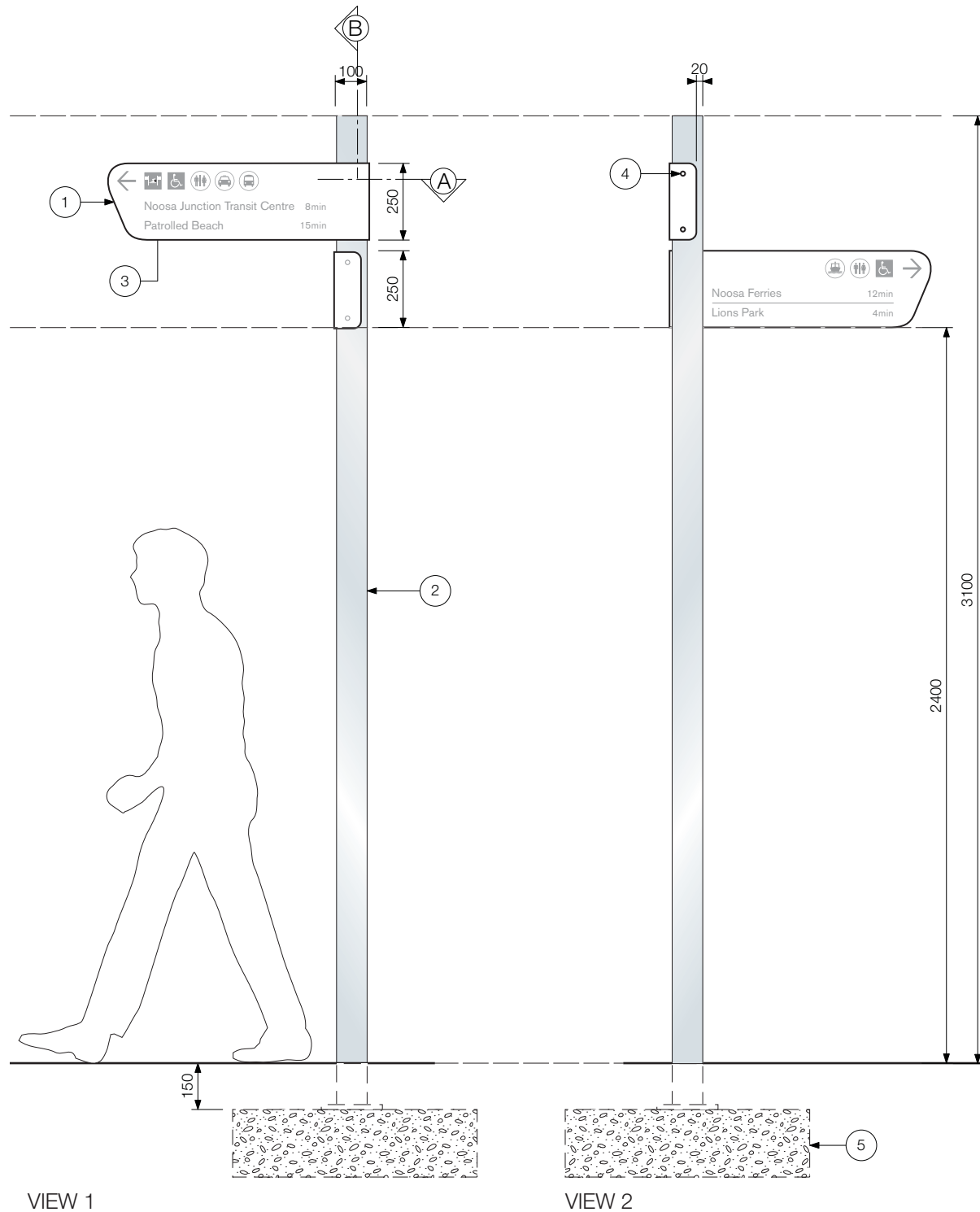

VIEW 1

VIEW 2

Elevations

Scale 1:20

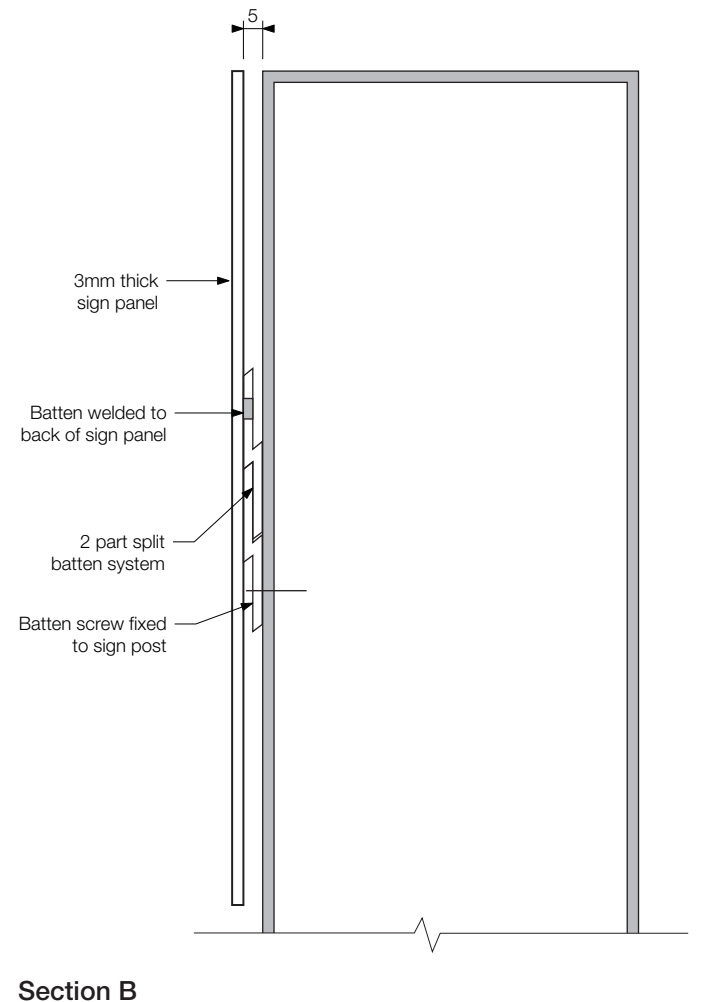

Section B

Scale 1:2

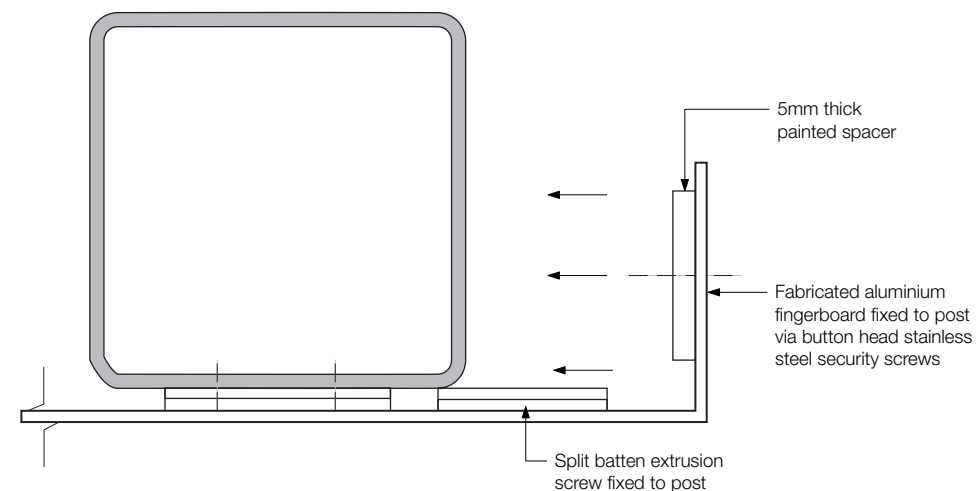

Section A

Scale 1:2

GENERAL CONSTRUCTION NOTES

- Refer to sheet 1 for General arrangement
- Refer to sheet 3 for Graphic layout details
- Refer to sheet 4 for Above ground install
- Refer to sheet 5 for Direct embed install
- Drawings show design intent. Any changes to specification which affects design intent must be approved by the SCRC Project Representative.
- All structural members, fixings and/or footings to be confirmed by sign maker's engineer.
- Signmaker to confirm all details for approval on shop drawings prior to manufacture.

Construction Details

1. 3mm thick fabricated aluminium sign panel with folded return. 2 pac painted or powdercoat to all visible sides, anti-graffiti clear spray coat finish all over. Fix 5mm thick spacer to panel edge.
2. 100 x 100 x 5mm SHS stainless steel post with fully welded base plate and capping. Electro polished finish to reduce tea-staining.
3. Front applied vinyl graphics with 2 pac satin finish, anti-graffiti spray clear coat over.
4. Sign panel fixed to post via security fixings. Post hexagon Socket button head machine stainless steel fixing on return edge. Signlink Split Batten LB to provide a support to post. Refer detail.

5.a FOOTING OPTION 1 - BELOW GROUND

Footing to be 150mm nominal to coordinate with paving. Reinforced concrete pad/pier footing to signmakers' engineer specification. All fixings shall be below ground level to reduce trip hazards. Re-instate / make good paving or pavement, with no changes of level greater than 3mm and no gradients steeper than 1:40.

5.b. FOOTING OPTION 2 - ABOVE GROUND

Mechanical anchors to existing concrete slab. Leveling grout as required. Fixing via M12 hold down bolts with stainless steel dome head nuts. Site inspection to confirm suitability of slab prior to installation.

Material Finish

Panel paint finish = Satin finish

Stainless steel post = Satin electro polished

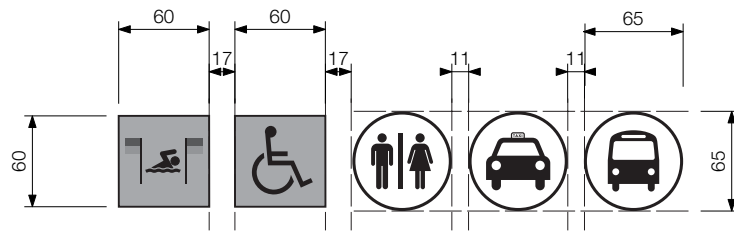

27 | **Noosa Junction Transit Centre** | 8min | 27

27 | **Patrolled Beach** | 15min | 27

GENERAL CONSTRUCTION NOTES

- Refer to sheet 1 for General arrangement
- Refer to sheet 2 for Construction details
- Refer to sheet 4 for Above ground install
- Refer to sheet 5 for Direct embed install
- Drawings show design intent. Any changes to specification which affects design intent must be approved by the SCRC Project Representative.
- Signmaker to confirm all details for approval on shop drawings prior to manufacture.

Graphic Details

FONT
All text = Berthold Akzidenz Grotesk Regular

COLOUR
Sign panel background = Dulux Woodland Grey®
Directional message = Avery White
Pictograms - Refer to Pictogram standards for details

Typical Graphic Layout

Scale 1:5

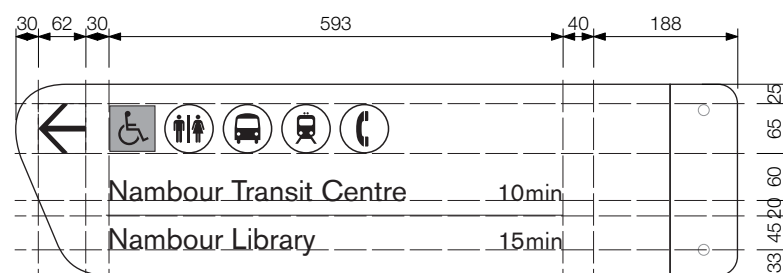
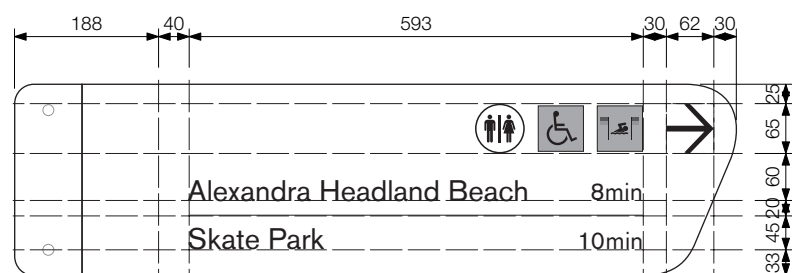
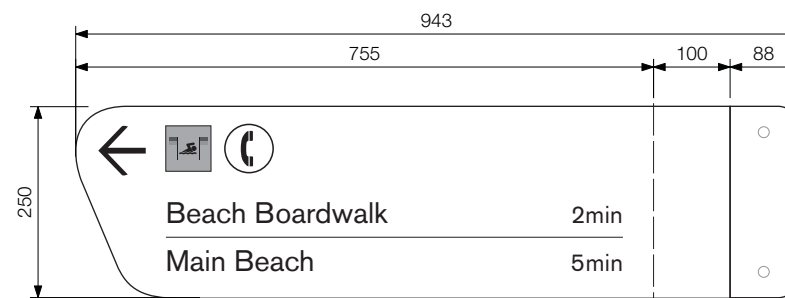
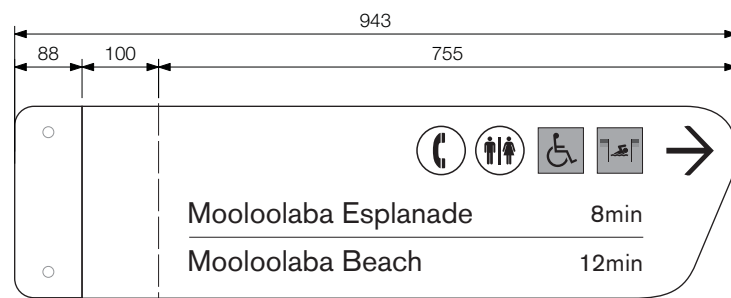

RIGHT DIRECTION

LEFT DIRECTION

Typical Graphic Layouts

Scale 1:10

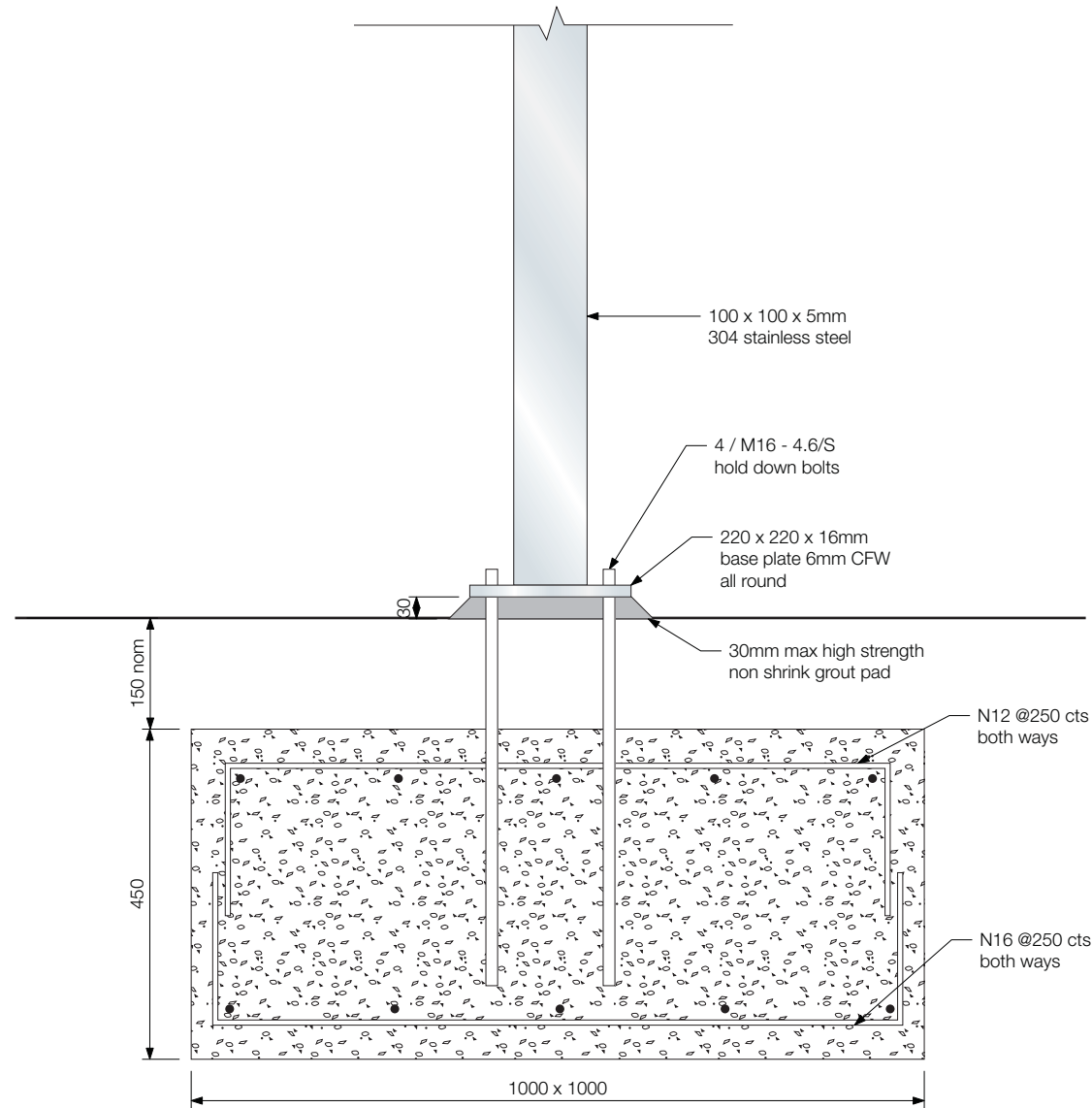

OPTION 1 - PAD FOOTING

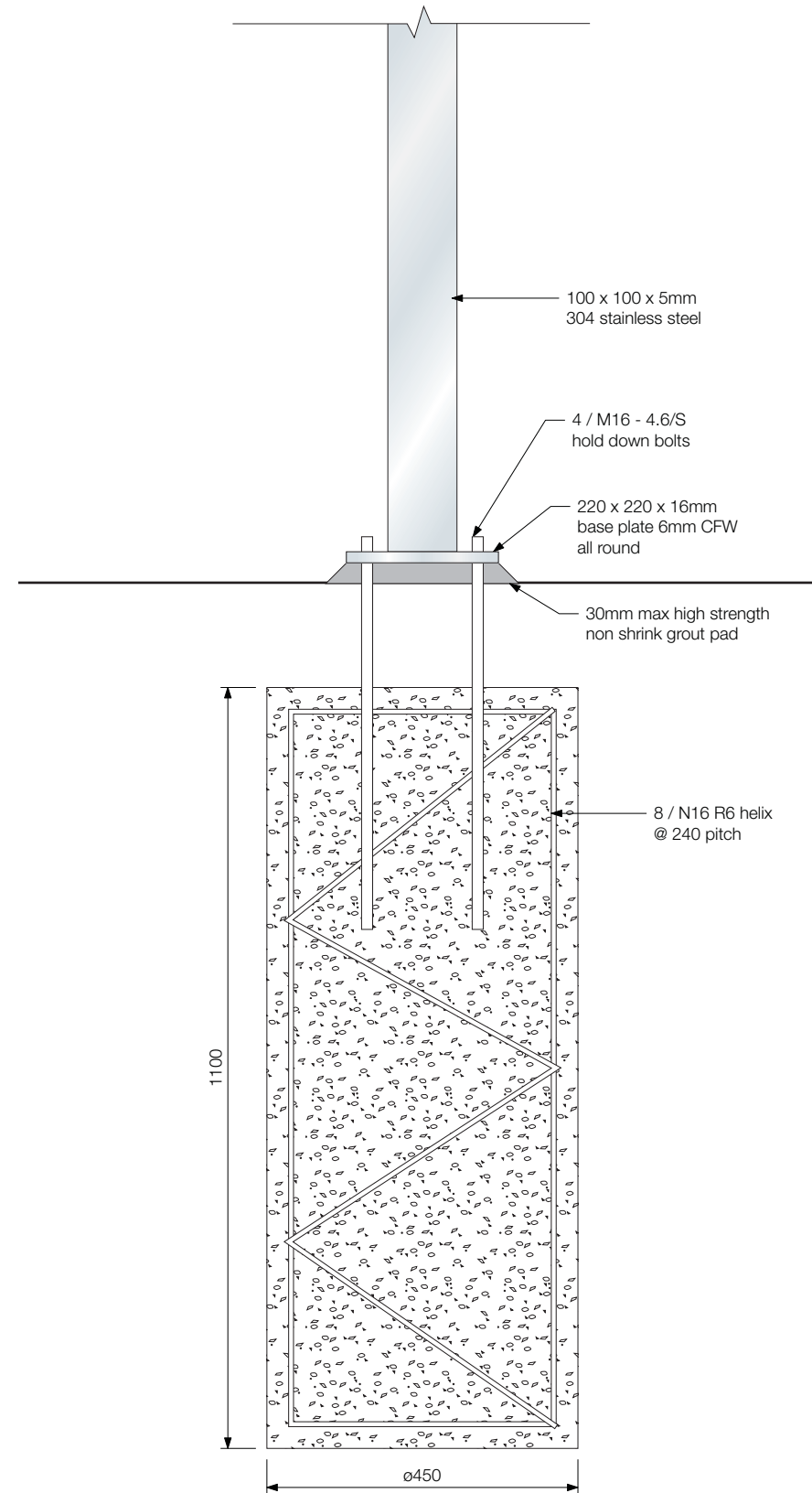

OPTION 2 - PIER FOOTING

GENERAL CONSTRUCTION NOTES

- Refer to sheet 1 for General Arrangement
- Refer to sheet 2 for Construction details
- Refer to sheet 3 for Graphic details
- Refer to sheet 5 for Direct embed footings
- Drawings show design intent. Any changes to specification which affects design intent must be approved by the SCRC Project Representative.
- Signmaker to confirm all details for approval on shop drawings prior to manufacture.

Note

- Specifications shown are for preliminary advice only.
- All structural members, fixings and/or footings to be confirmed by sign maker's engineer.

Above Ground Footing Detail

Scale 1:10

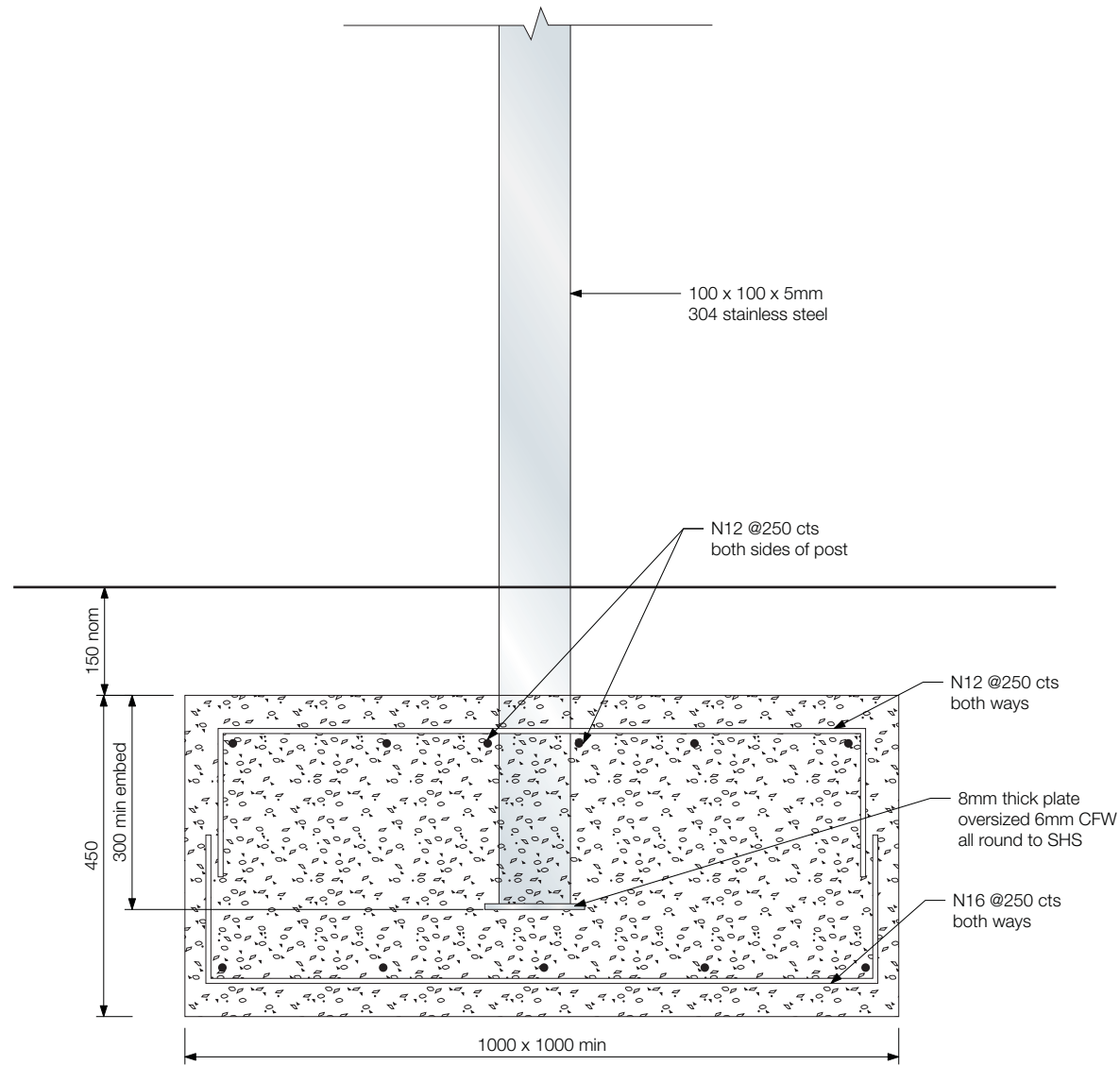

OPTION 1 - PAD FOOTING

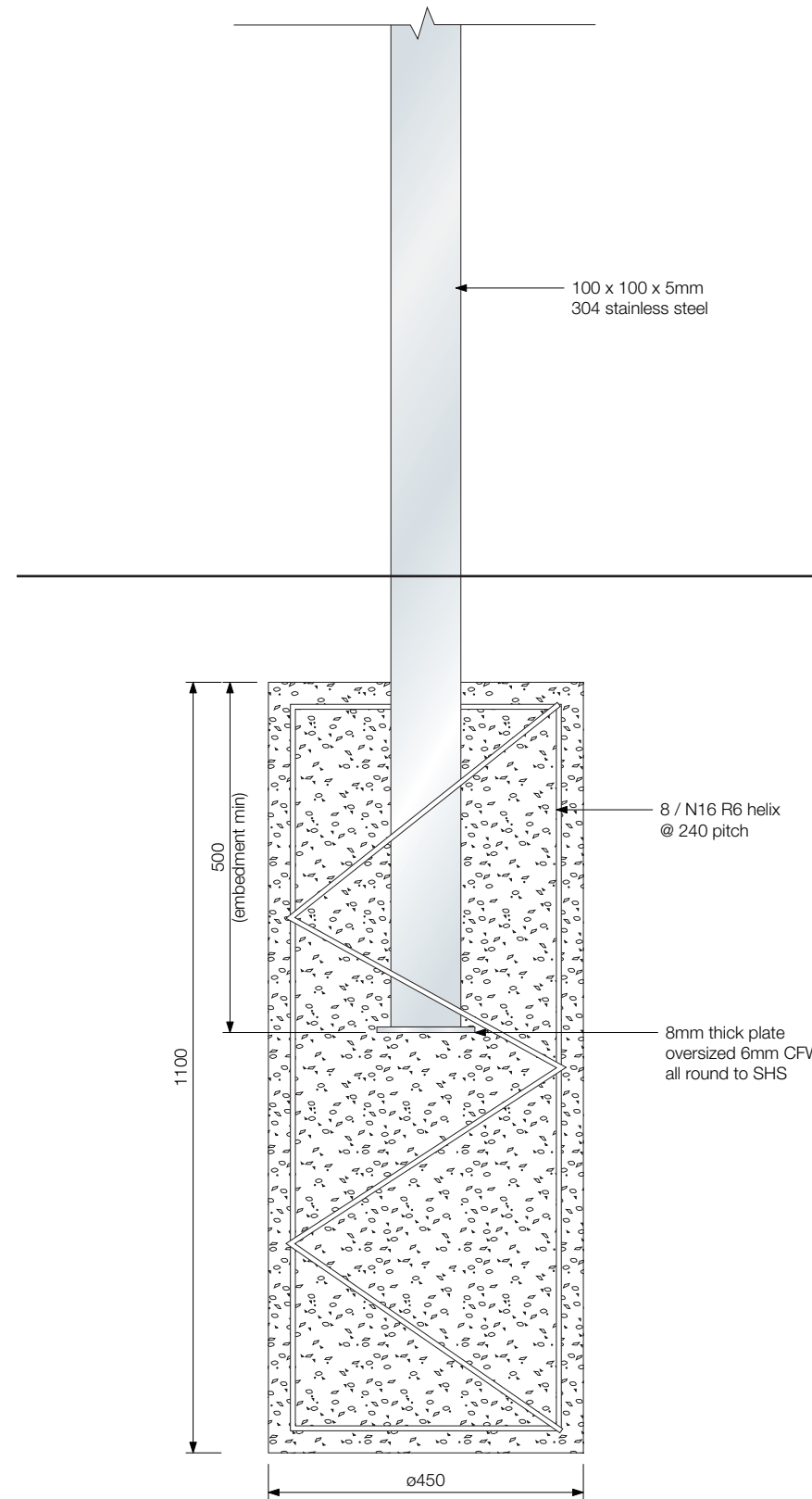

OPTION 2 - PIER FOOTING

GENERAL CONSTRUCTION NOTES

- Refer to sheet 1 for General Arrangement
- Refer to sheet 2 for Construction details
- Refer to sheet 3 for Graphic details
- Refer to sheet 4 for Above ground footings
- Drawings show design intent. Any changes to specification which affects design intent must be approved by the SCRC Project Representative.
- Signmaker to confirm all details for approval on shop drawings prior to manufacture.

Note

- Specifications shown are for preliminary advice only.
- All structural members, fixings and/or footings to be confirmed by sign maker's engineer.

Direct Embed Footing Detail

Scale 1:10

GENERAL CONSTRUCTION NOTES

- Refer to sheet 1 for General Arrangement
- Refer to sheet 2 for Construction details
- Refer to sheet 3 for Graphic details
- Refer to sheet 4 for Above ground footings

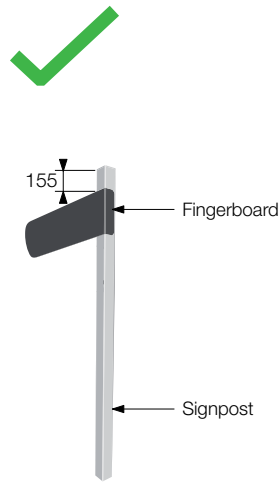

Single Fingerboard

Single directional fingerboard can point in any direction but top edge of fingerboard must be located 155mm from top of sign post

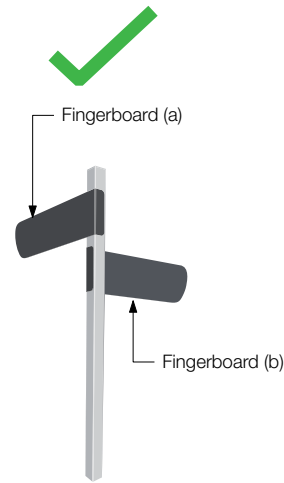

Two Fingerboards 90°

If there are two sign fingerboards at 90° to each other (a) (b), fingerboard (b) is located under fingerboard (a)

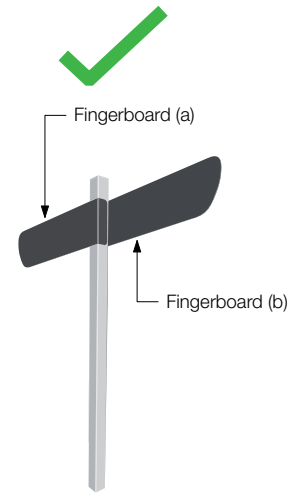

Two Fingerboards 180°

If there are two sign fingerboards at 90° to each other (a) (b), fingerboard (b) is located under fingerboard (a)



Three Fingerboards

A three directional layout always has two sign fingerboards sitting above a single fingerboard



Four Fingerboards

A four fingerboard sign has two fingerboards (180° to each other) at the top of the sign post and another two (180° to each other) underneath

ALLOWED

Correct application for Directional Fingerboards

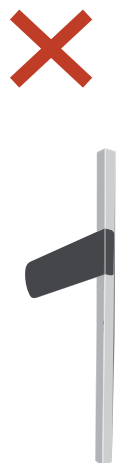

Single Fingerboard

The top edge of the single fingerboard should not sit lower than 155mm from the top edge of the sign post.



Two Fingerboards 90°

Two fingerboards at 90° should not sit on the same level



Two Fingerboards 180°

Two fingerboards at 180° should not sit on different levels



Three Fingerboards

A single fingerboard must not sit above two other fingerboards in a three directional layout

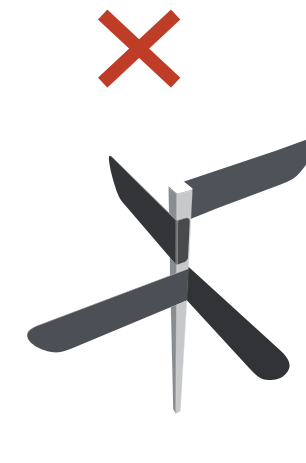

Four Fingerboards

Fingerboards should not sit 90° from each other on the same level

NOT ALLOWED

This configuration is not allowed and will not be accepted.

GENERAL CONSTRUCTION NOTES

- Refer to sheet 2 for Construction details
- Refer to sheet 3 for Graphic layout details

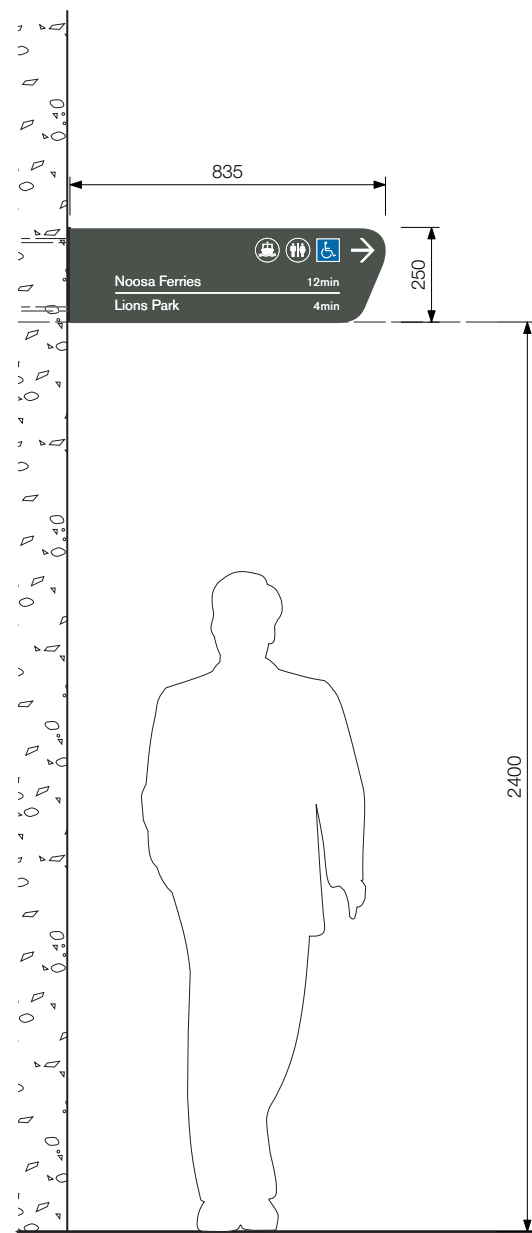

FRONT VIEW

FIXED TO WALL / BUILDING



FRONT VIEW

MOUNTED TO EXISTING POST

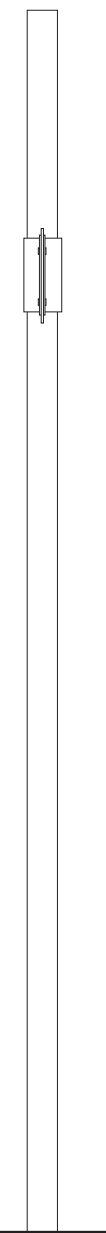

SIDE VIEW

Typical Elevations

Scale 1:20

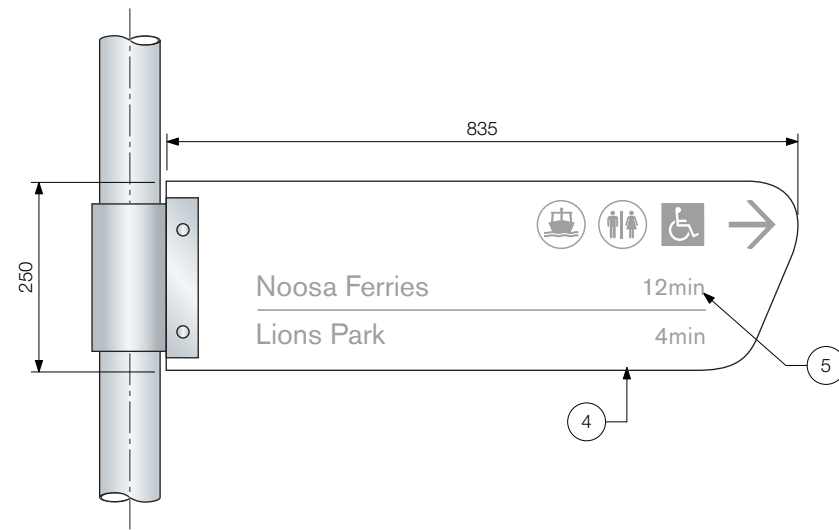

FRONT VIEW

MOUNTED TO EXISTING POST

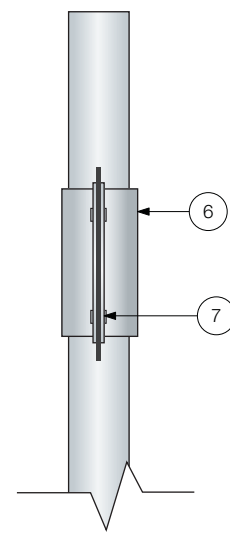

SIDE VIEW

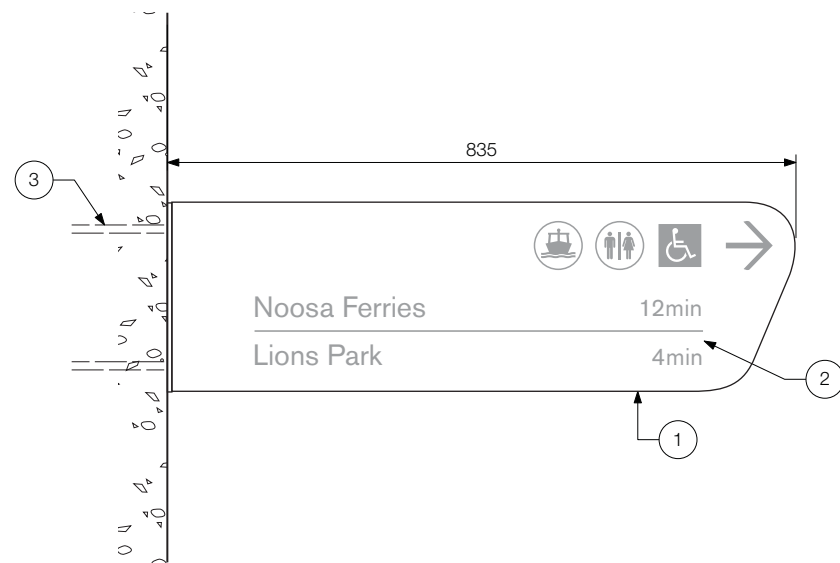

FRONT VIEW

FIXED TO WALL / BUILDING

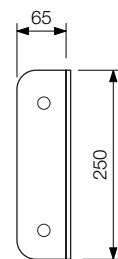

SIDE VIEW

GENERAL CONSTRUCTION NOTES

- Refer to sheet 1 for General arrangement
- Refer to sheet 3 for Graphic layout details
- Drawings show design intent. Any changes to specification which affects design intent must be approved by the SCRC Project Representative.
- All structural members, fixings and/or footings to be confirmed by sign maker's engineer.
- Signmaker to confirm all details for approval on shop drawings prior to manufacture.

Construction Details

Wall mounted projecting sign

1. 3mm thick fabricated aluminium sign panel with folded return. 2 pac painted or powdercoated to all visible sides, anti-graffiti clear spray coat finish all over.
2. Front applied vinyl graphics with 2 pac satin finish, anti-graffiti spray clear coat over.
3. Sign panel fixed to wall via suitable mechanical anchor. 2 x M12 Chemset anchors, 120mm min embed. Provide neoprene washer between panel and wall.

Existing post mounted projecting sign

4. 3mm thick aluminium sign panel. 2 pac painted to all visible sides, anti-graffiti clear spray coat finish all over.
5. Front applied vinyl graphics with 2 pac satin finish, anti-graffiti spray clear coat over.
6. Sign panel fixed to post via two-part, slide and lock system aluminium bracket.
 - 7a. Option 1
BR-8-A Appleton clamp to suit 50mm NB post and wide panel. 2 x M8 x 20mm Zincplated Hex Head bolts and nuts post fixings.
 - 7b. Option 2 - Clampon anti-theft
BR-121-A Appleton clamp to suit 50mm NB post and wide panel. Anti-theft fixings.

Material Finish

Panel paint finish = Satin finish

Clamp = Mill finish aluminium

Elevations

Scale 1:10

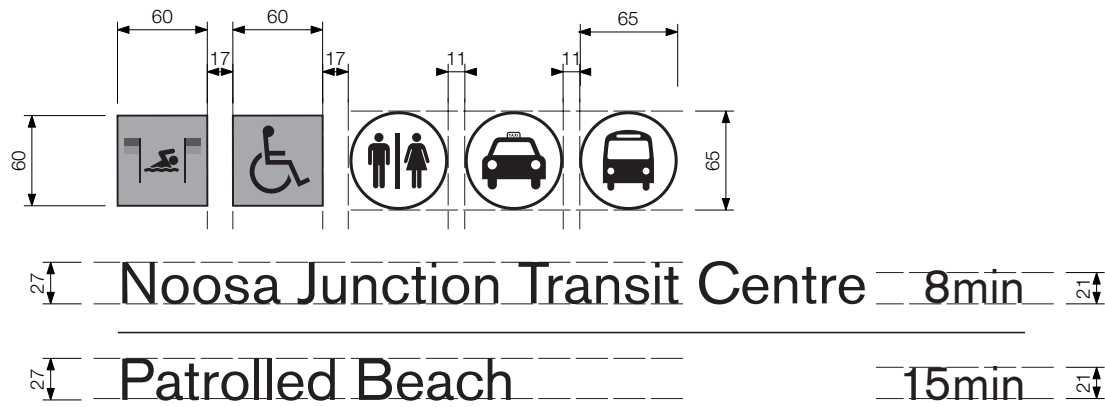

GENERAL CONSTRUCTION NOTES

- Refer to sheet 1 for General arrangement
- Refer to sheet 2 for Construction details
- Drawings show design intent. Any changes to specification which affects design intent must be approved by the SCRC Project Representative.
- Signmaker to confirm all details for approval on shop drawings prior to manufacture.

Graphic Details

FONT
 All text = Berthold Akzidenz Grotesk Regular

COLOUR
 Sign panel background = Dulux Woodland Grey®
 Directional message = Avery White
 Pictograms - Refer to Pictogram standards for details

Typical Graphic Layout

Scale 1:5

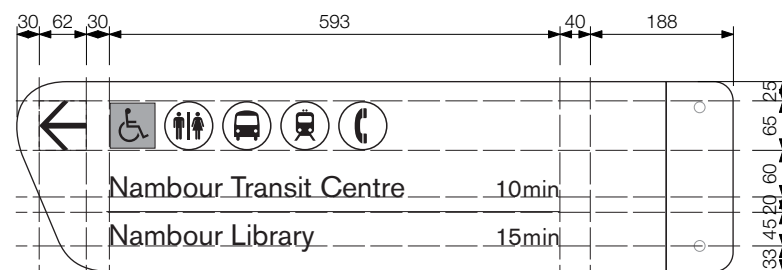
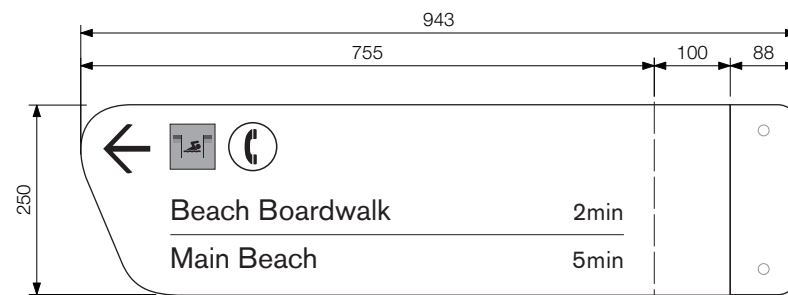
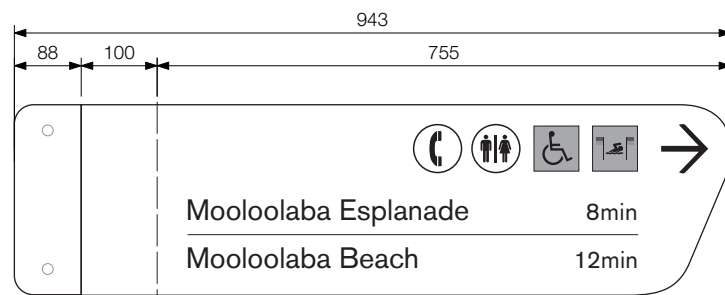

RIGHT DIRECTION

LEFT DIRECTION

Typical Graphic Layouts

Scale 1:10

SUITE 2



Timber and Aluminium

Sign Suite Summary

Sign Type 2.1 – Information Map Sign (Primary)

Sign Type 2.2 – Information Map Sign (Secondary)

Sign Type 2.3 – Directional Blade Sign

Sign Type 2.4 – Directional Finger Post Sign

Sign Type 2.5 – Directional Finger (Panel only)

SUITE 2 SIGN SUMMARY

- Sign Type 2.1 – Information Map Sign (Primary)
- Sign Type 2.2 – Information Map Sign (Secondary)
- Sign Type 2.3 – Directional Blade Sign
- Sign Type 2.4 – Directional Finger Post Sign
- Sign Type 2.5 – Directional Finger (Panel only)

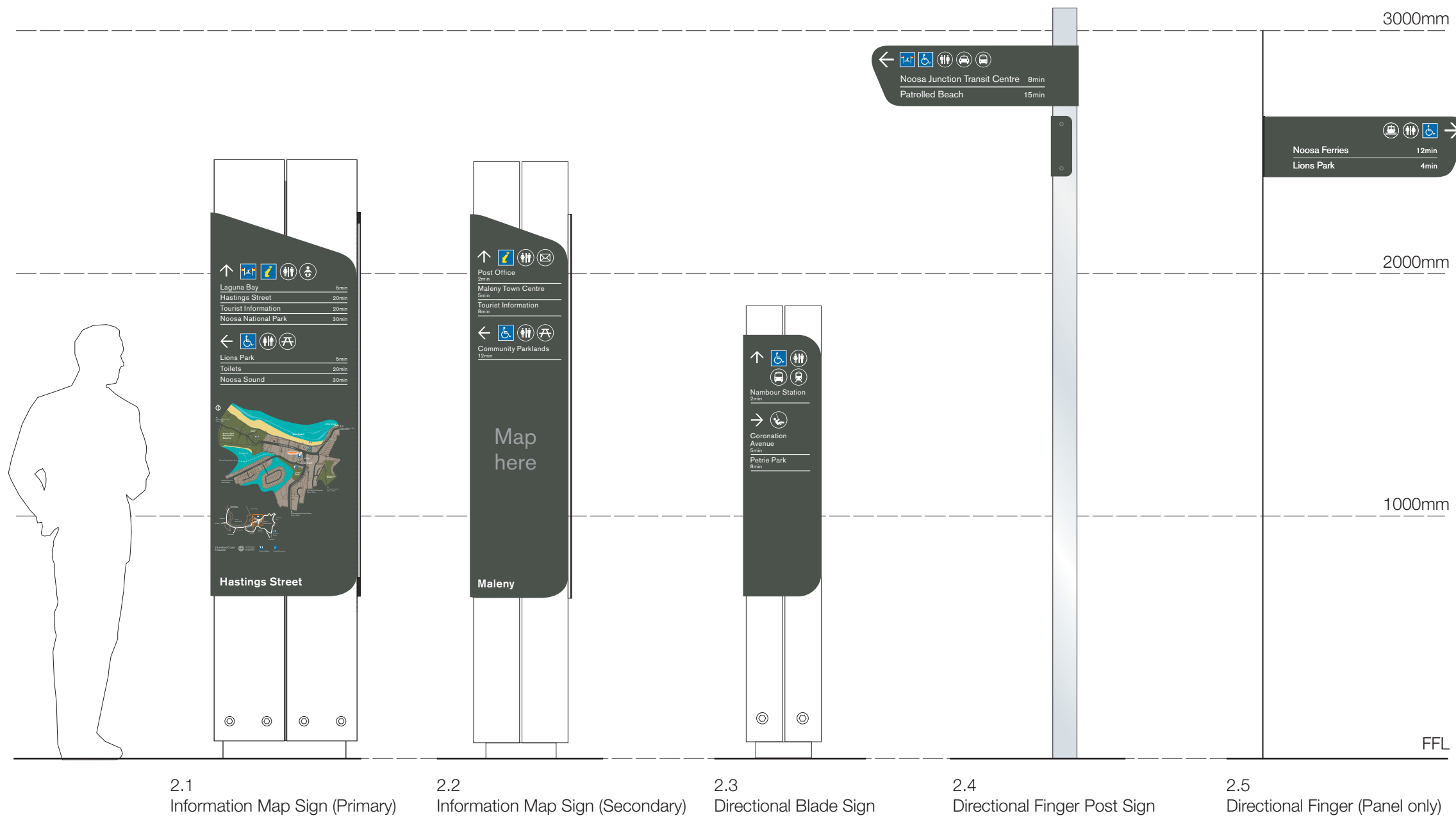

Elevations
Scale 1:20

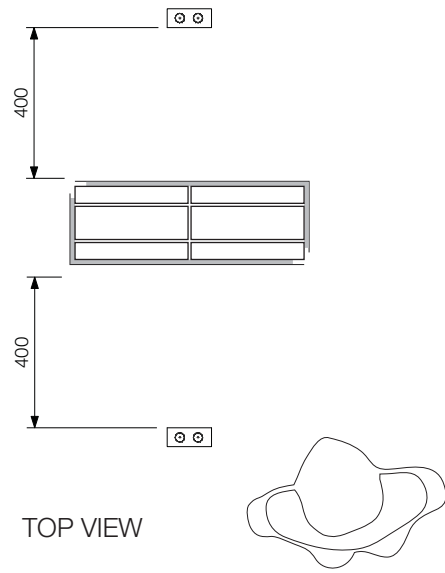

Map graphics indicative and shown for illustrative purposes only

GENERAL CONSTRUCTION NOTES

- Refer to sheet 2 for Construction details
- Refer to sheet 3 for Graphic layout details
- Refer to sheet 4 for Structural & Footing details

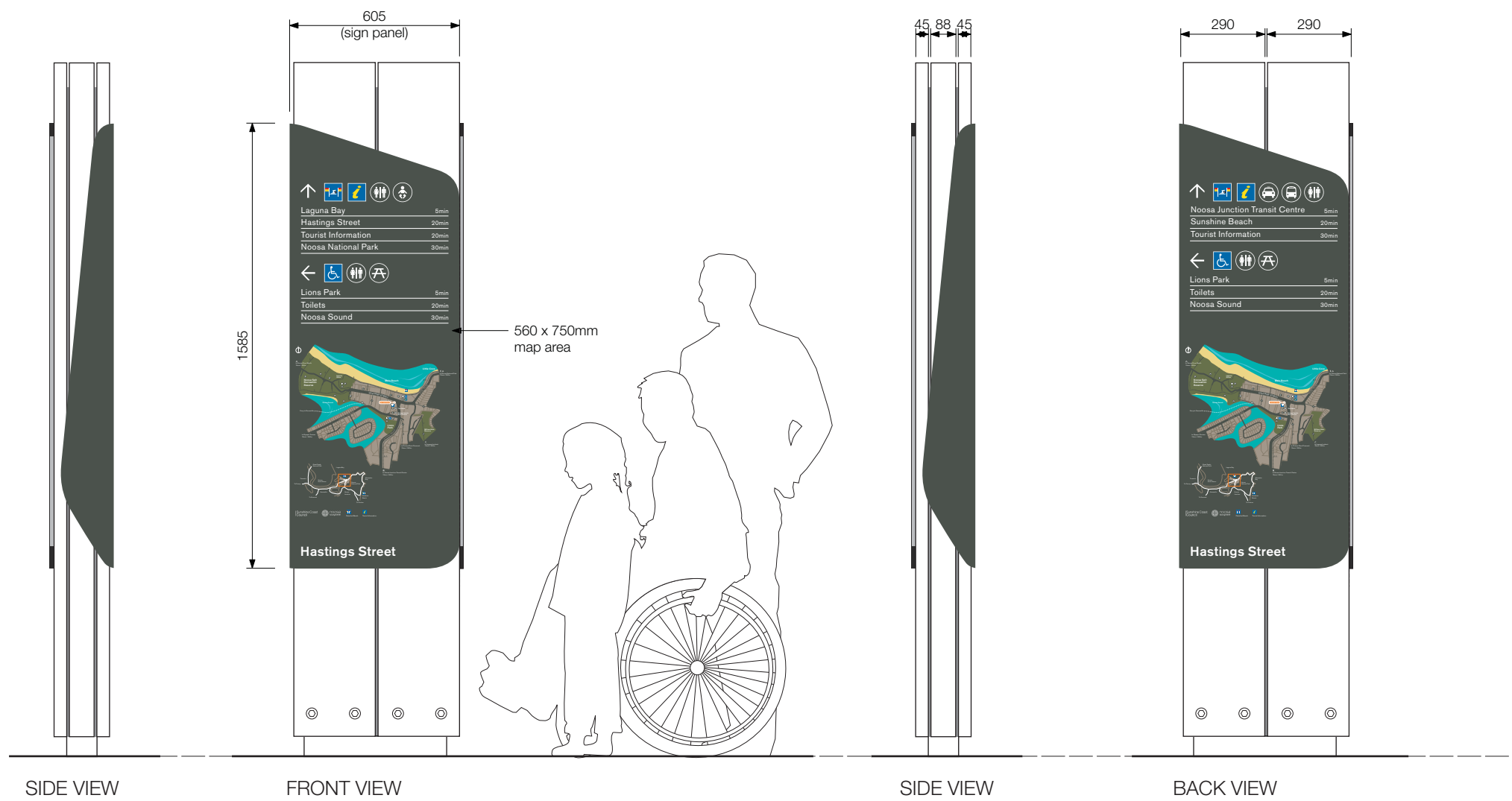

Elevations
 Scale 1:20

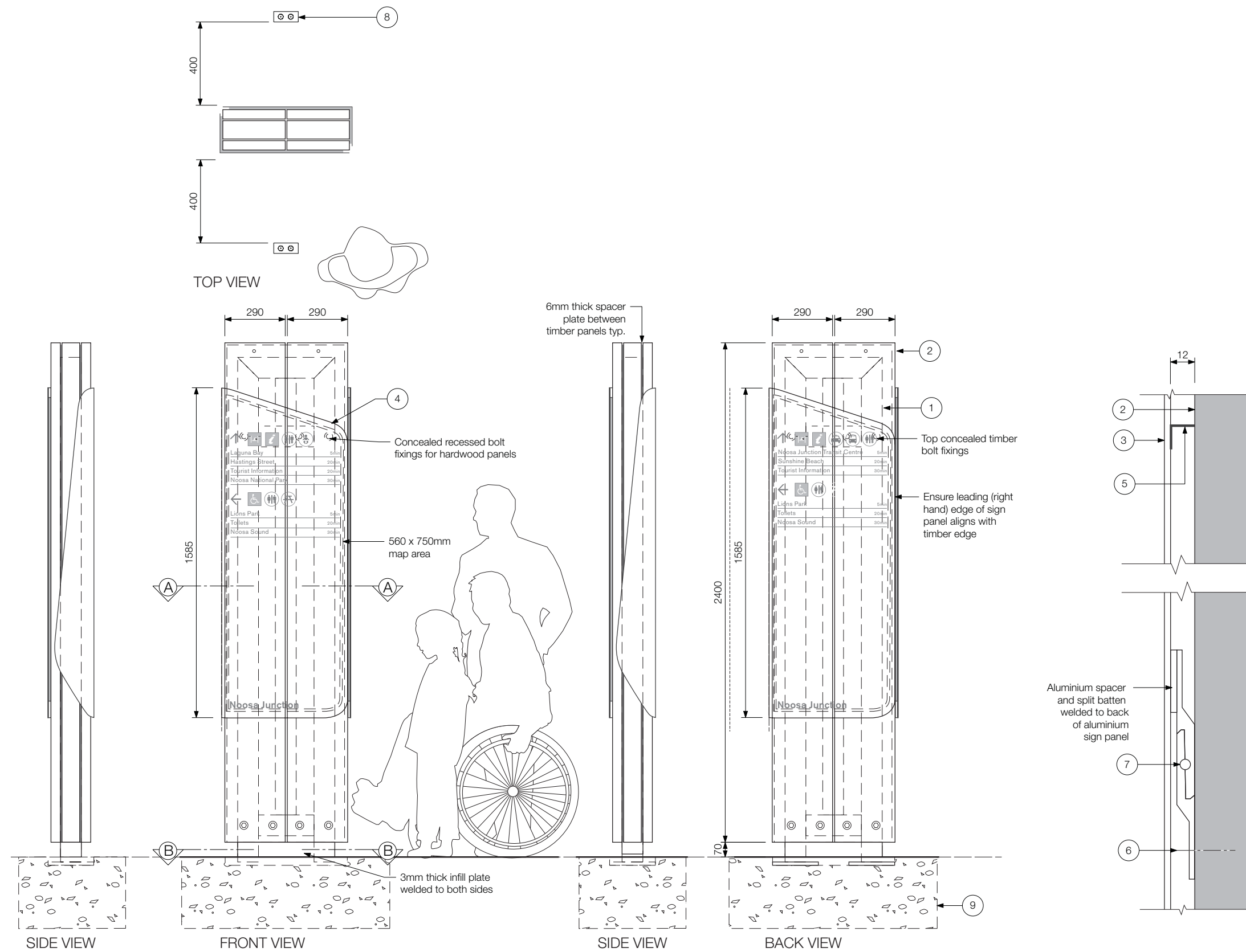

Elevations
 Scale 1:20

Mounting Detail
 Scale 1:2

GENERAL CONSTRUCTION NOTES

- Refer to sheet 1 for General arrangement
- Refer to sheet 3 for Graphic layout details
- Refer to sheet 4 for Structural & Footing details
- Refer to Appendix B for Engineer Specifications
- Drawings show design intent. Any changes to specification which affects design intent must be approved by the SCRC Project Representative.
- Signmaker to confirm all details for approval on shop drawings prior to manufacture.

Construction Details

1. Fabricated 100 x 100 x 5mm 314 Grade SHS internal frame with all connections CFW. 6mm thick plate 't' section welded between frames to provide spacer detail. 10mm thick base plate. Weld 3mm thick infill plate at base, all welds ground smooth.
2. 290 x 45mm thick dressed, class 2 min. timber panels to both sides of internal frame. 70 x 88mm class 2 timber members mechanically fixed via no. 14 type 17 stainless steel screws at each side through plate. Provide neoprene washers as required.
3. 3mm thick fabricated aluminium sign panel with folded return. 2 pac painted or powdercoat to all visible sides with anti-graffiti spray clear coat finish all over.
- 4a. Directional graphics - front applied vinyl graphics over clear polymeric printed map vinyl.
- 4b. Map graphics - printed onto clear polymeric vinyl and cut to outer shape of sign panel
5. 12 x 12mm aluminium angle to follow panel profile. Pin fixed to back of sign panel. Drill out holes to access split batten for removal.
6. Screw fix Signlink HD2 split batten aluminium extrusion to timber. Ensure track is spaced off evenly to allow sign face to locate and slide onto tracks.
7. Sign face to mount to split batten and mechanically fixed via grub screw.
8. Option A - Inlite (supplier)
 'Inlite' Tactic 2 (Deltalight - 213 42 12) ground recessed mounted LED uplights, installed on both sides of sign. Light to wash over both sign faces.
 Option B - Lumascope (supplier)
 LS393 - LED inground recessed mounted uplights, installed on both sides of sign. Light to wash over both sign faces. Fitting to be provided with 'gimbal' to direct lighting on sign face.
9. Remote control light gear location to be coordinated with SCRC Project Representative. Refer specification for lighting details.
9. Reinforced concrete footing to engineer's specification. All fixings shall be below ground level to reduce trip hazards. Re-instate / make good paving or pavement, with no changes of level greater than 3mm and no gradients steeper than 1:40.

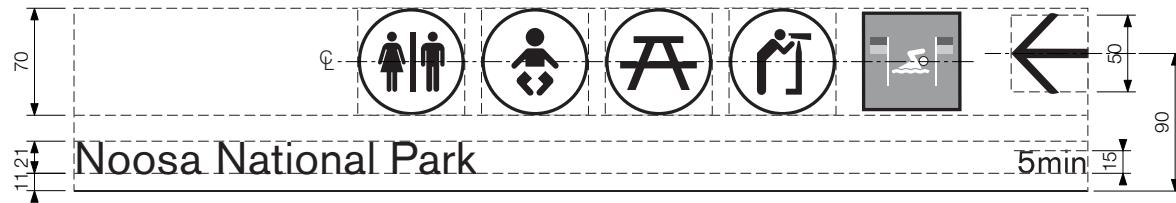

MESSAGE, ARROW & PICTOGRAM

Typical Graphic Detail

Scale 1:5

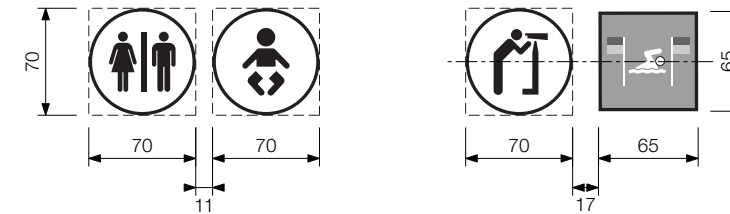

PICTOGRAM RELATIONSHIPS

GENERAL CONSTRUCTION NOTES

- Refer to sheet 1 for General arrangement
- Refer to sheet 2 for Construction details
- Refer to sheet 4 for Structural & Footing details

Graphic Production

Directional graphics & Pictograms

Front applied Avery vinyl graphics over clear polymetric printed vinyl.

Map graphics

Full colour, high quality digital print direct to premium clear 5-year polymeric external vinyl. Signmaker to provide manufacturer's warranty. To be printed on flatbed printer.

Clear vinyl to be cut to outer shape of panel and trimmed 3mm from sign panel edge. For folded edge, cut vertical along fold

Print white first and over-print colours to ensure the opacity of the print.

Sign panel to be clear coated with an anti-graffiti 2 pac satin finish. The clear coat shall be consistent and compatible with the paint finish and applied as per manufacturers instructions. Clear coat shall consist of four sprayed layers of clear non yellowing 2 pac polyurethane paint.

Graphic Details

FONT

Directional message = Akzidenz Grotesk Regular
Identification name = Akzidenz Grotesk Medium
Map = Refer Map standards for details

COLOUR

Sign panel background = Dulux Woodland Grey®
Directional message = Avery White
Pictograms - Refer to Pictogram standards for details

Note

Panel finish = Satin finish

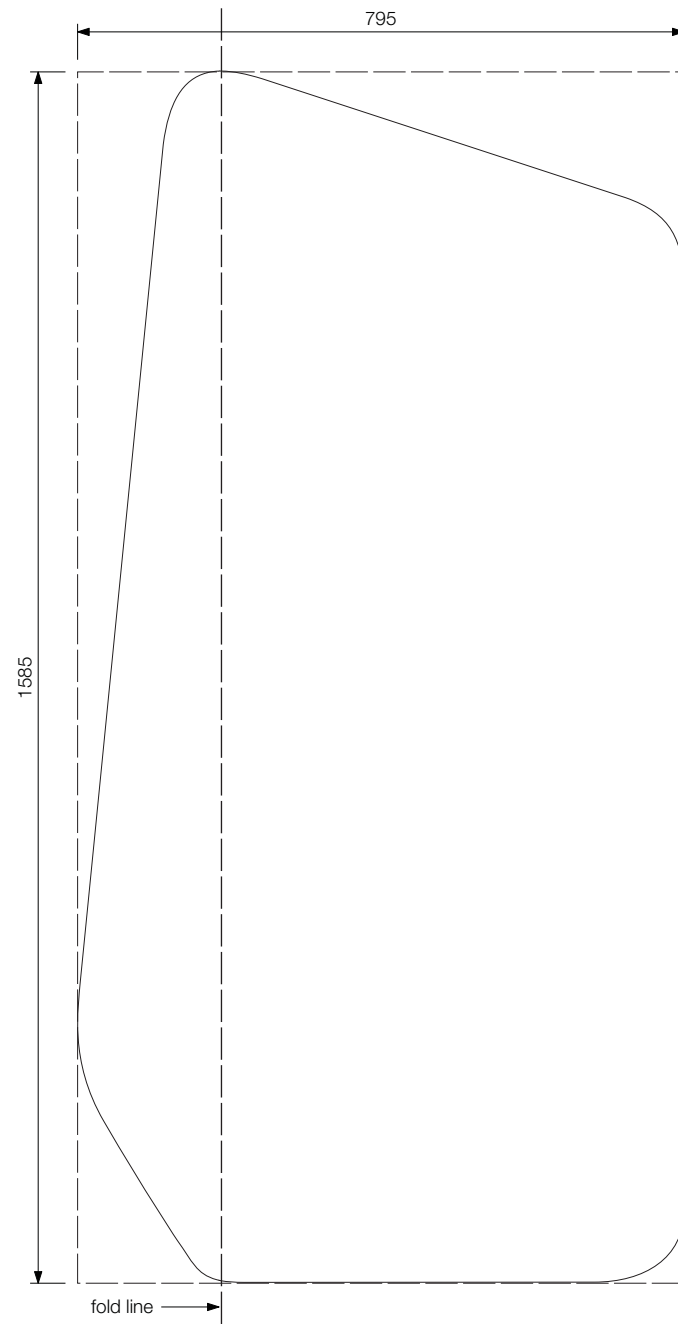

PANEL SHAPE

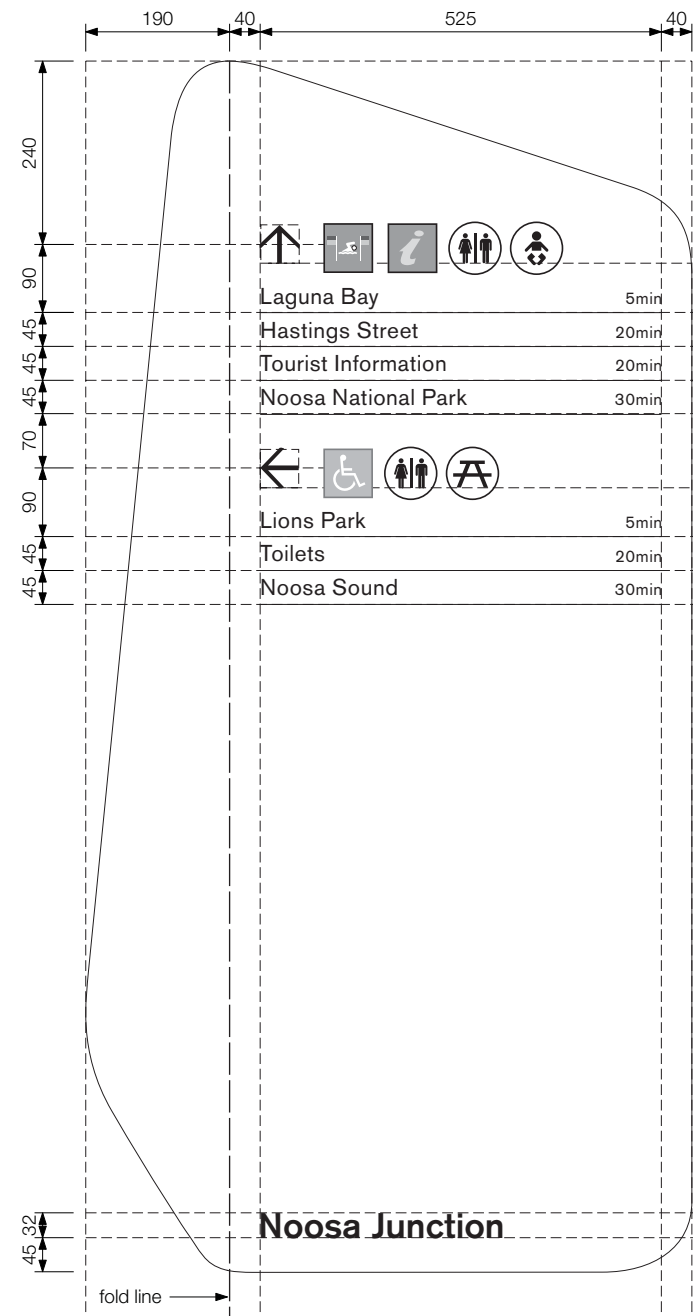

FRONT VIEW

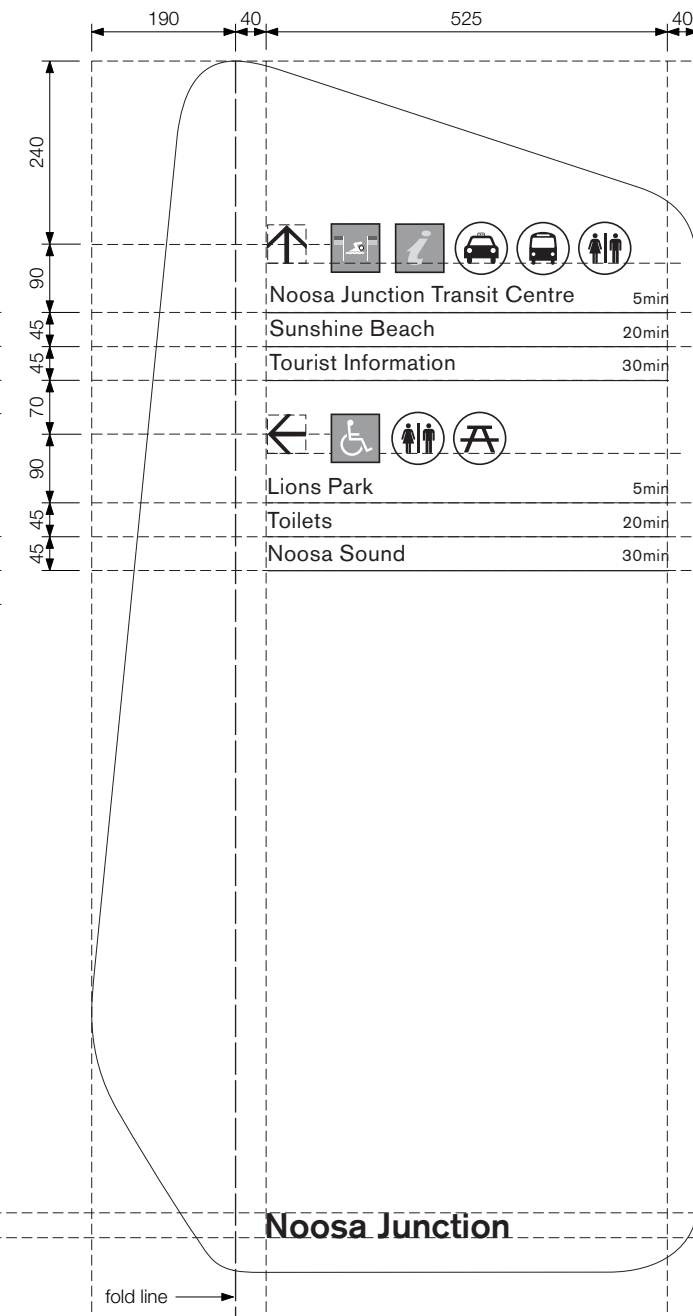

BACK VIEW

Typical Graphics

Scale 1:10

GENERAL CONSTRUCTION NOTES

- Refer to sheet 2 for Construction details
- Refer to sheet 3 for Graphic layout details
- Refer to sheet 4 for Structural & Footing details

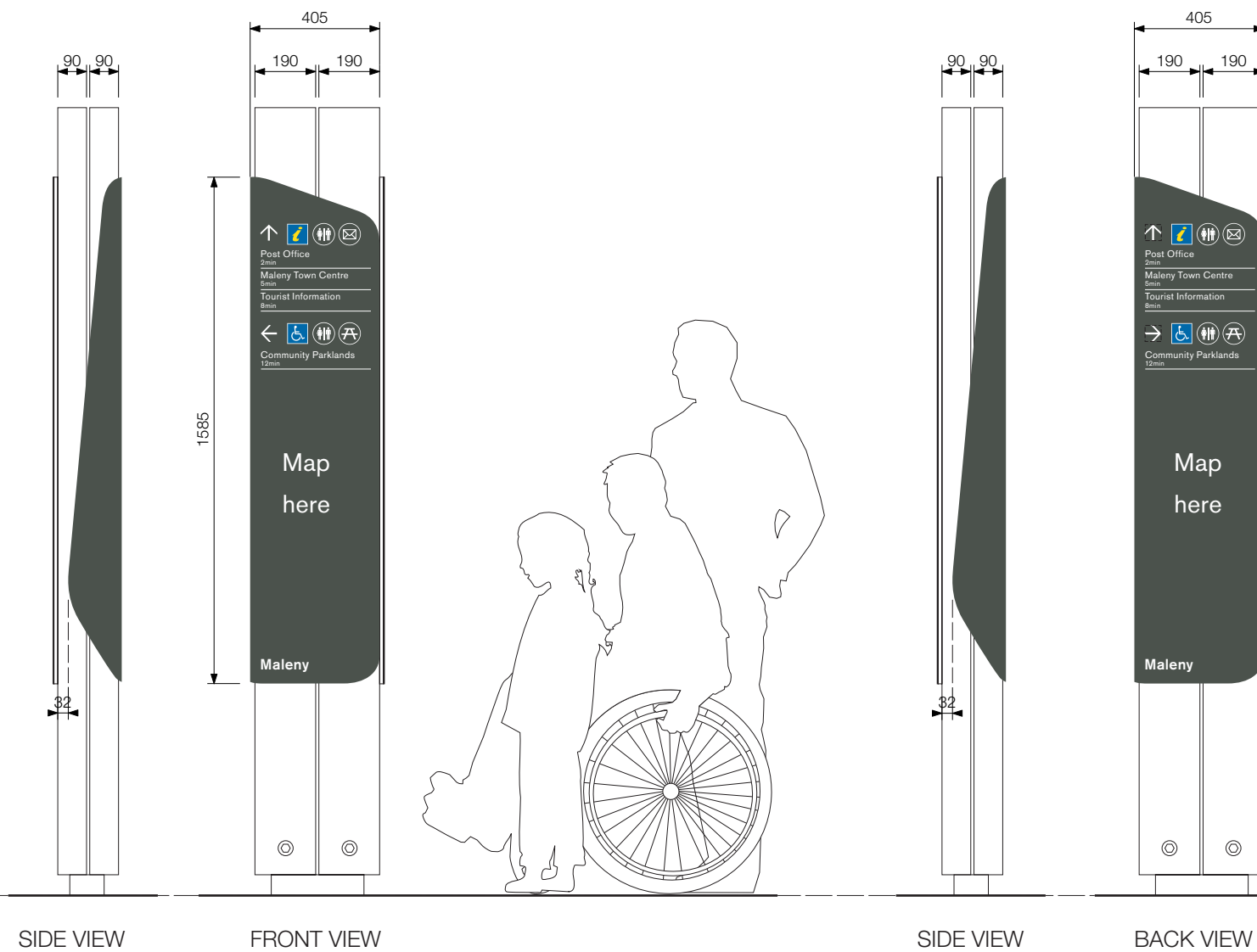
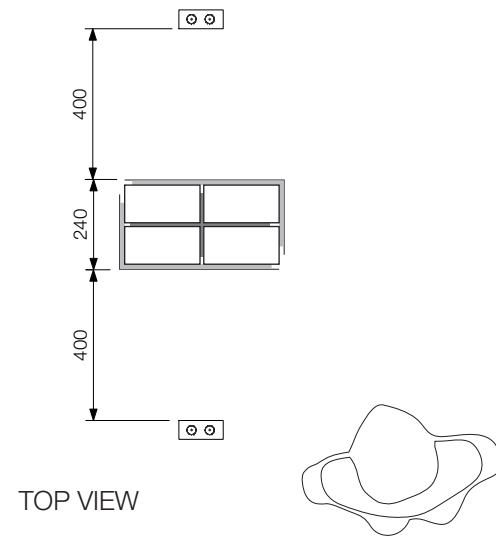

Elevations
 Scale 1:20

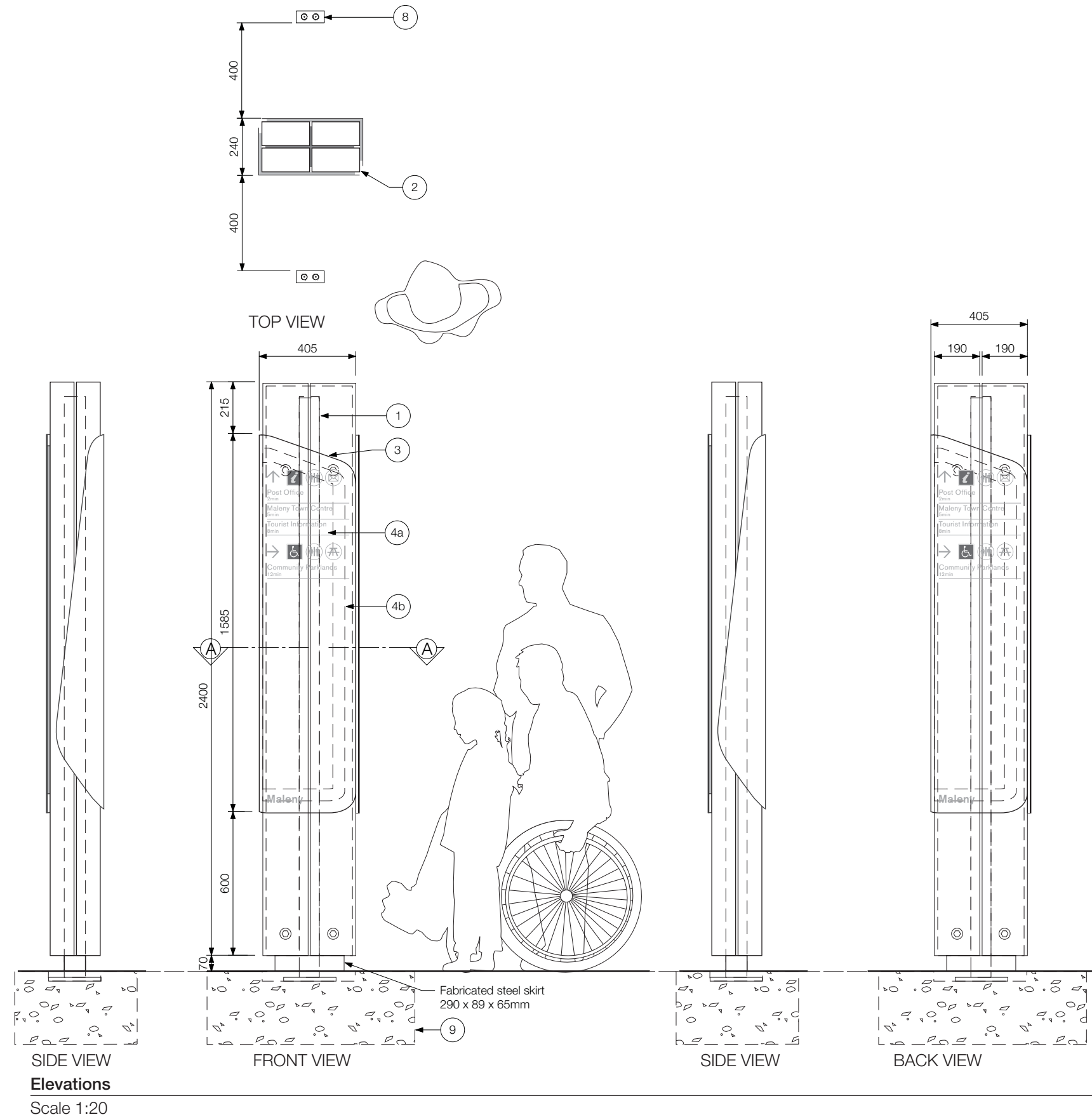

GENERAL CONSTRUCTION NOTES

- Refer to sheet 1 for General arrangement
- Refer to sheet 3 for Graphic layout details
- Refer to sheet 4 for Structural & Footing details
- Drawings show design intent. Any changes to specification which affects design intent must be approved by the SCRC Project Representative.
- All structural members, fixings and/or footings to be confirmed by sign maker's engineer.
- Signmaker to confirm all details for approval on shop drawings prior to manufacture.

Construction Details

1. Fabricated mild steel RHS internal frame with fully welded 6mm thick plate and 16mm thick base plate. Provide steel skirt around base of sign to conceal post. Ground weld smooth. Galvanised finish.
2. 190 x 90mm thick dressed Class 2 min. timber hardwood panels, profiled to suit internal frame. Hardwood panels mechanically fixed via galvanised bolts.
3. 3mm thick fabricated aluminium sign panel with folded return. 2 pac painted to all visible sides with anti-graffiti spray clear coat finish all over.
- 4a. Directional graphics - front applied vinyl graphics over clear polymeric printed map vinyl.
- 4b. Map graphics - printed onto clear polymeric vinyl and cut to outer shape of sign panel
5. 12 x 12mm aluminium angle to follow panel profile. Pin fixed to back of sign panel. Drill out holes to access split batten for removal.
6. Screw fix Signlink HD2 split batten aluminium extrusion to timber. Ensure track is spaced off evenly to allow sign face to locate and slide onto tracks.
7. Sign face to mount to split batten and mechanically fixed via grub screw.
8. Option A - Inlite (supplier)
 'Inlite' Tactic 2 (Deltaight - 213 42 12) ground recessed mounted LED uplights, installed on both sides of sign. Light to wash over both sign faces .
- Option B - Lumascape (supplier)
 LS393 - LED inground recessed mounted uplights, installed on both sides of sign. Light to wash over both sign faces. Fitting to be provided with 'gimbal' to direct lighting on sign face.
9. Reinforced concrete pad/pier footing to sign maker's engineer specification. All fixings shall be below ground level to reduce trip hazards. Re-instate / make good paving or pavement, with no changes of level greater than 3mm and no gradients steeper than 1:40.

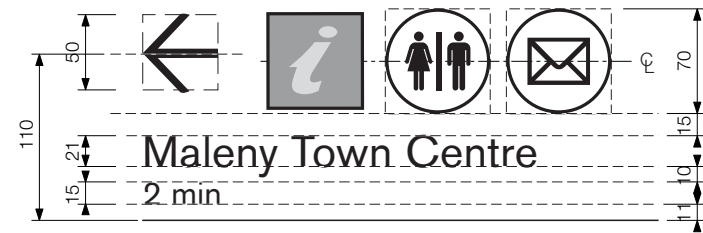

MESSAGE, ARROW & PICTOGRAM

Typical Graphic Detail

Scale 1:5

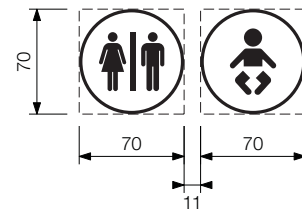

PICTOGRAM RELATIONSHIPS

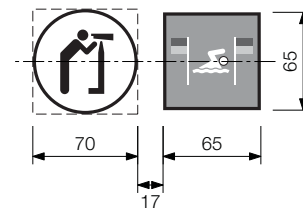

GENERAL CONSTRUCTION NOTES

- Refer to sheet 1 for General arrangement
- Refer to sheet 2 for Construction details
- Refer to sheet 4 for Structural & Footing details

Graphic Production

Directional graphics & Pictograms

Front applied Avery vinyl graphics over clear polymeric printed vinyl.

Map graphics

Full colour, high quality digital print direct to premium clear 5-year polymeric external vinyl. Signmaker to provide manufacturer's warranty. To be printed on flatbed printer.

Clear vinyl to be cut to outer shape of panel and trimmed 3mm from sign panel edge. For folded edge, cut vertical along fold

Print white first and over-print colours to ensure the opacity of the print.

Sign panel to be clear coated with an anti-graffiti 2 pac satin finish. The clear coat shall be consistent and compatible with the paint finish and applied as per manufacturers instructions. Clear coat shall consist of four sprayed layers of clear non yellowing 2 pac polyurethane paint.

Graphic Details

FONT

Directional message = Akzidenz Grotesk Regular
Identification name = Akzidenz Grotesk Medium
Map = Refer Map standards for details

COLOUR

Sign panel background = Dulux Woodland Grey®
Directional message = Avery White
Pictograms - Refer to Pictogram standards for details

Note

Panel finish = Satin finish

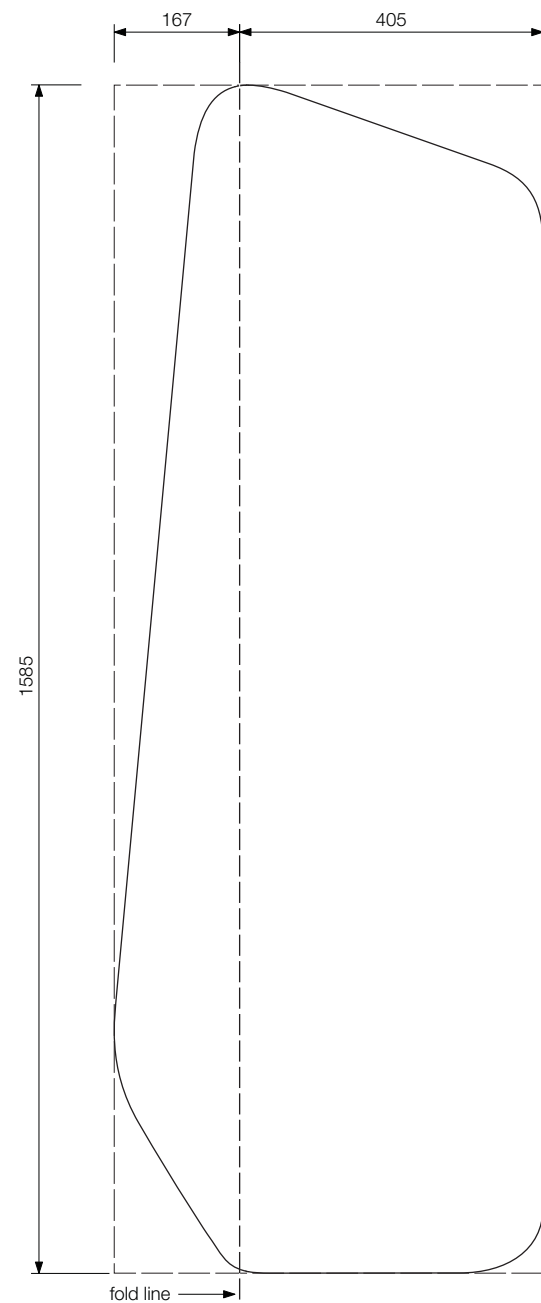

PANEL SHAPE

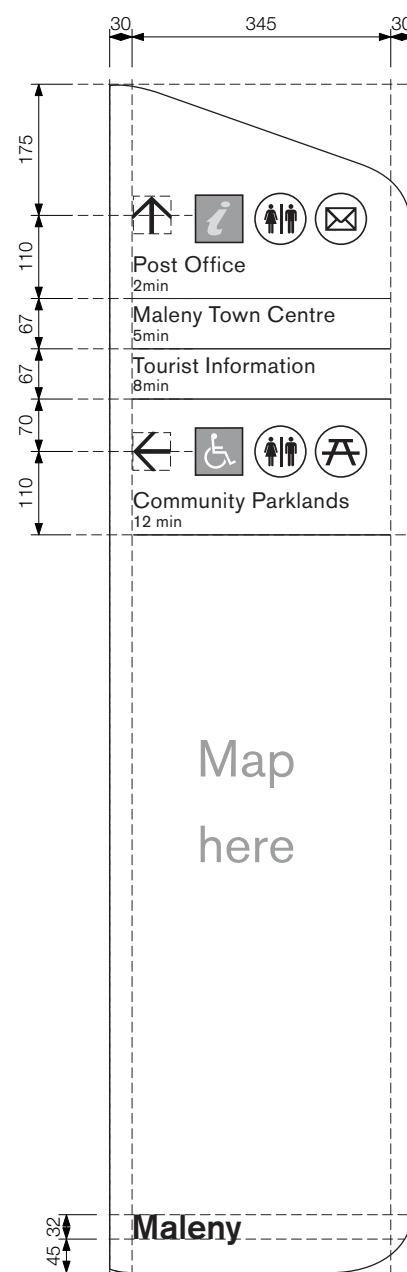

FRONT VIEW

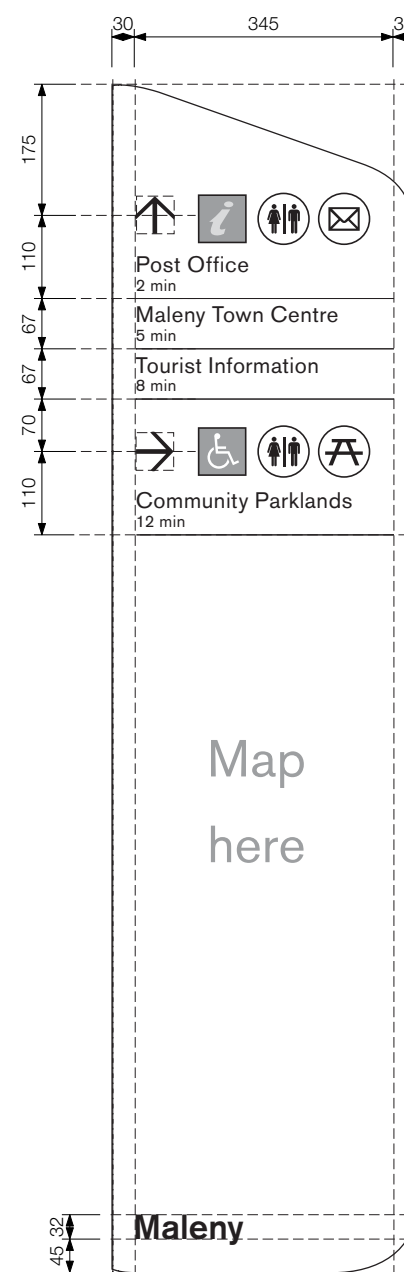

FRONT VIEW

Typical Graphic Detail

Scale 1:10

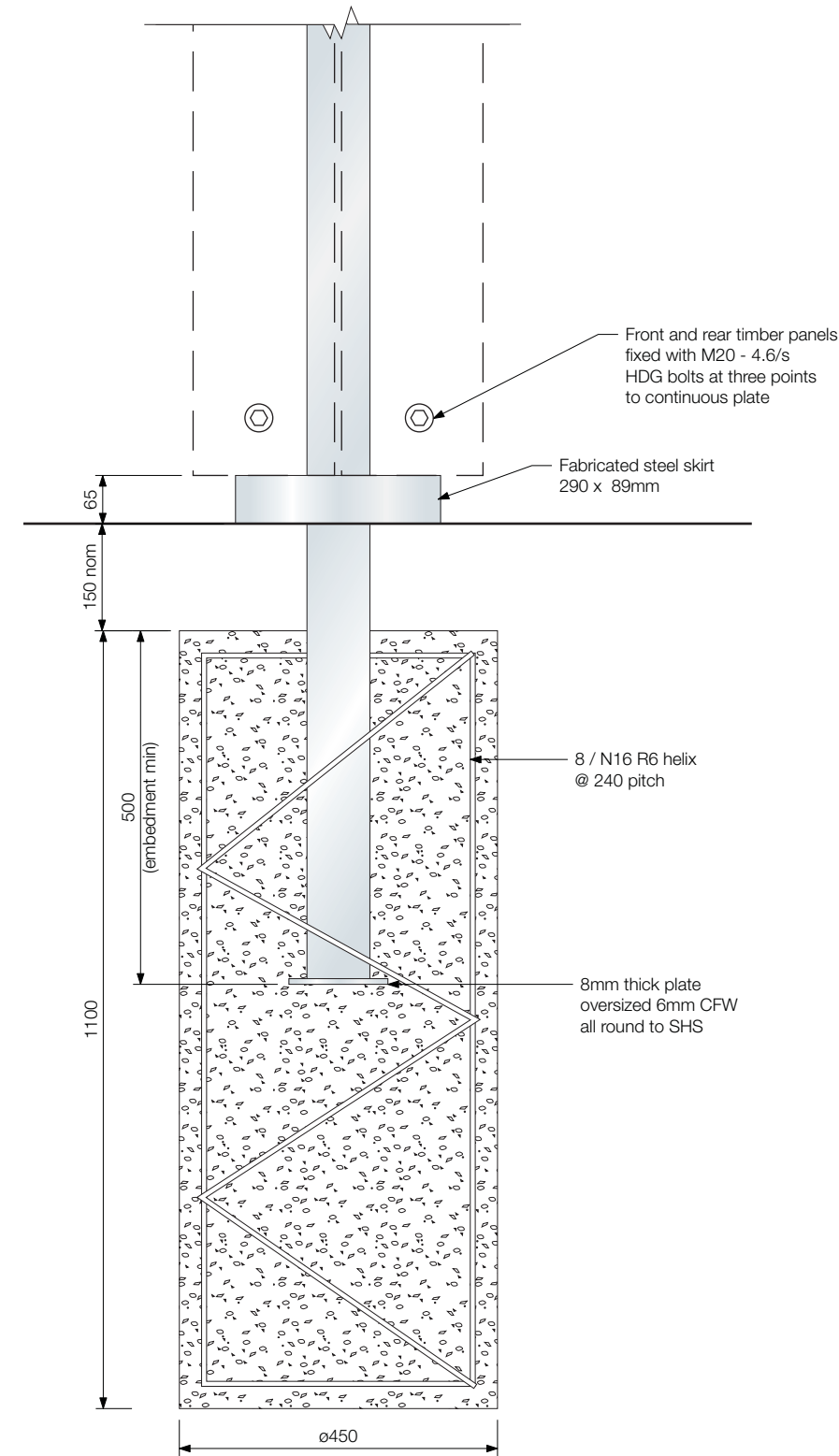

Pier footing

Direct Embed Footing Detail

Scale 1:10

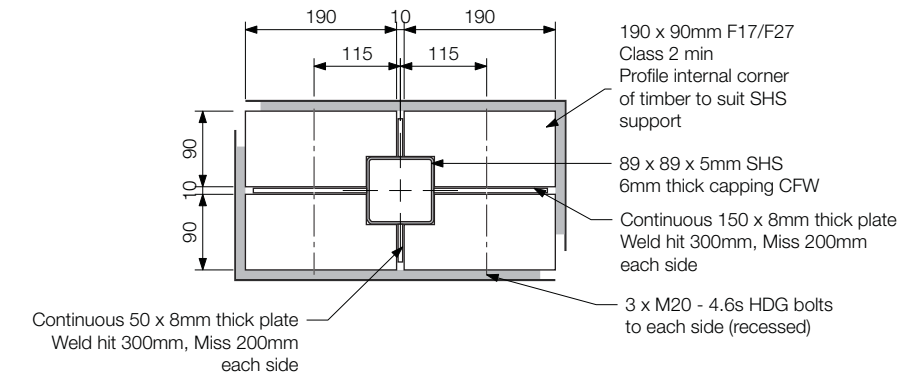

Section A (Sheet 2)

Scale 1:10

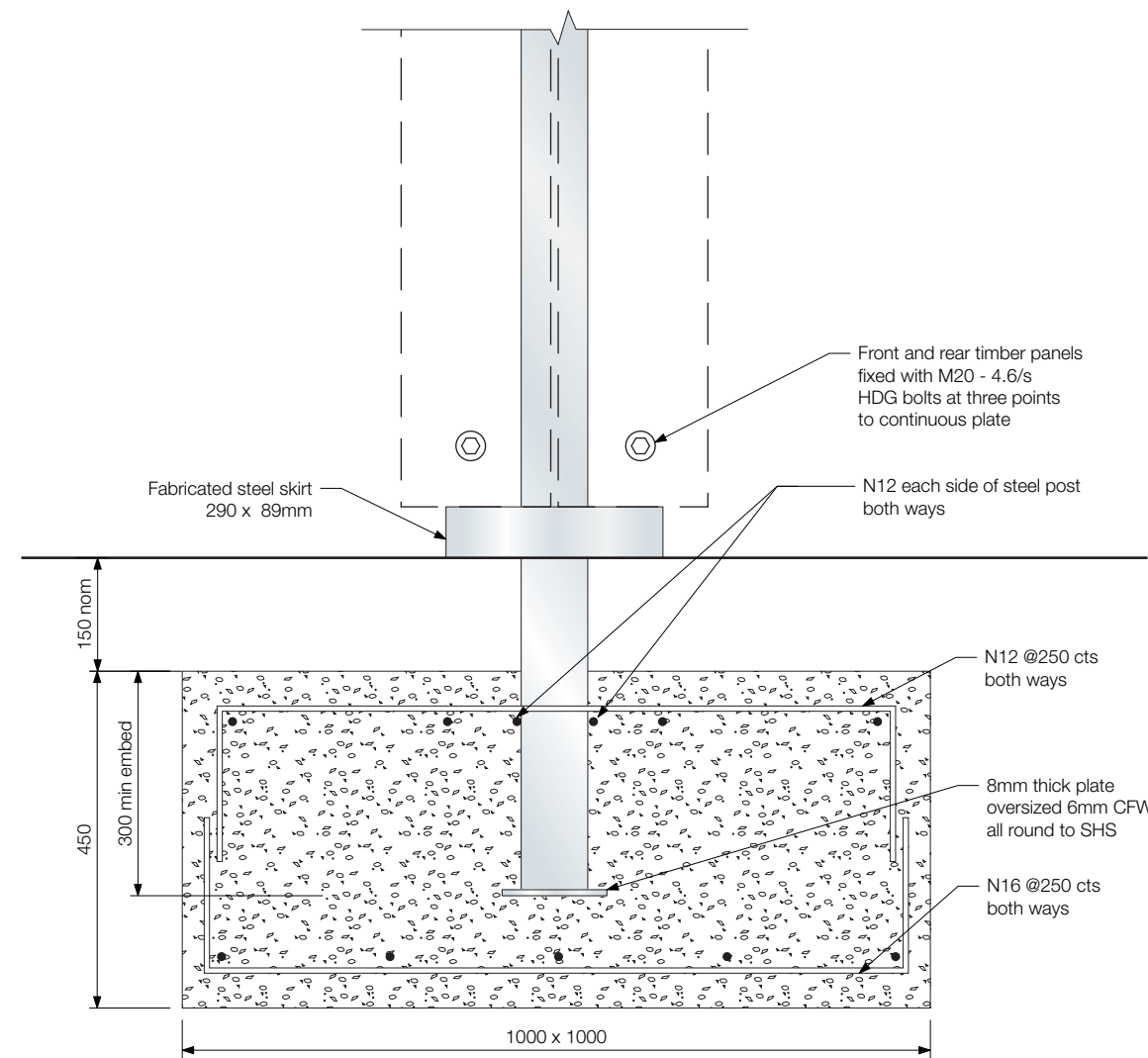

Pad footing

GENERAL CONSTRUCTION NOTES

- Refer to sheet 1 for General Arrangement
- Refer to sheet 2 for Construction details
- Refer to sheet 3 for Graphic details

Note

- Specifications shown are for preliminary advice only.
- All structural members, fixings and/or footings to be confirmed by sign maker's engineer.

Timber Specification

- All timber to be Minimum Class 2 F17/F27 hardwood
- Timber finish:
 1. Dressed / machined timber to specified size
 2. Tanalith E / ACQ Treatment
 3. CN oil finish top coat
 4. Treat with Tanacoat oil

GENERAL CONSTRUCTION NOTES

- Refer to sheet 2 for Construction details
- Refer to sheet 3 for Graphic layout details
- Refer to sheet 4 for Structural & Footing details

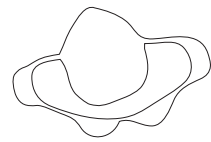
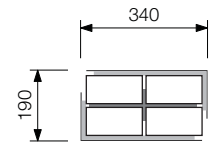

TOP VIEW

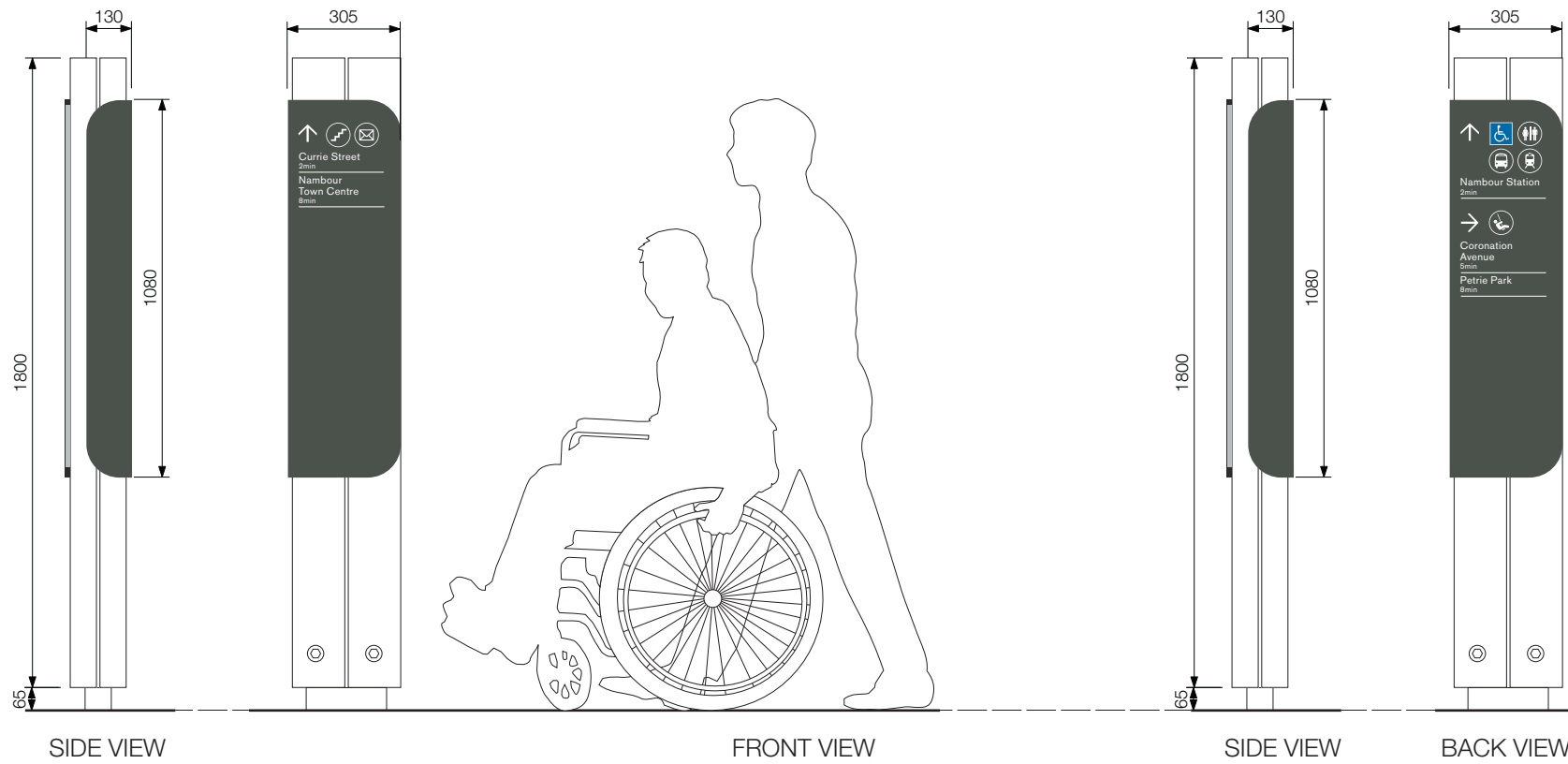

Elevations

Scale 1:20

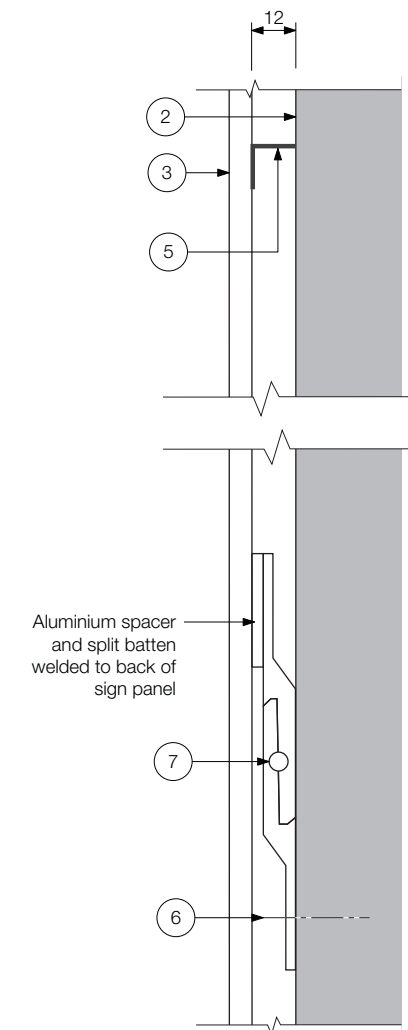
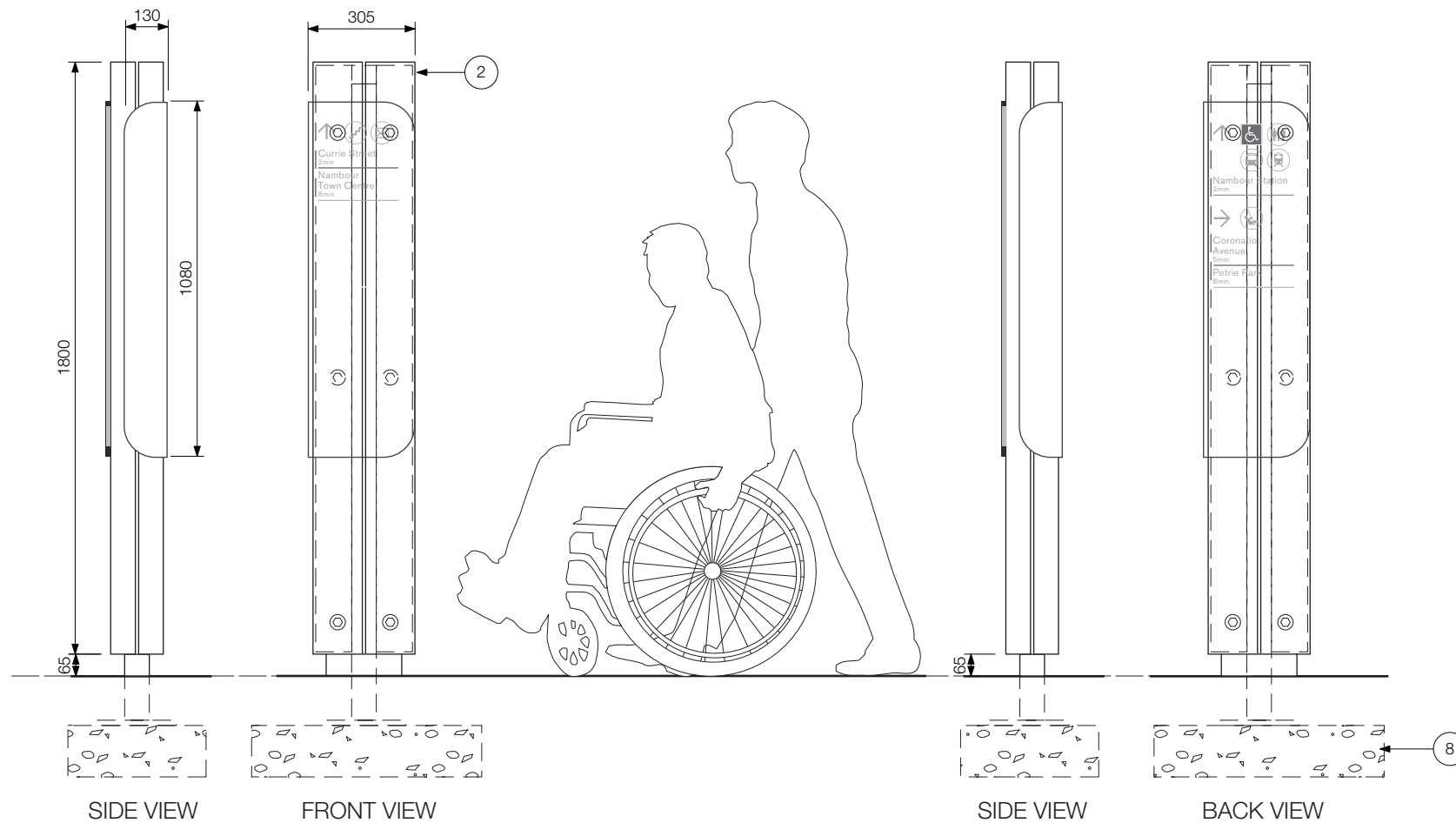
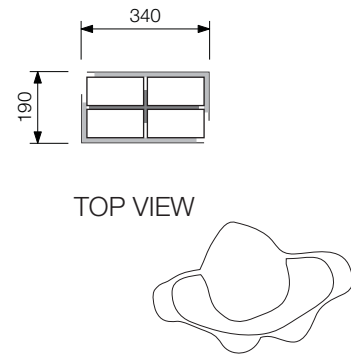

GENERAL CONSTRUCTION NOTES

- Refer to sheet 1 for General arrangement
- Refer to sheet 3 for Graphic layout details
- Refer to sheet 4 for Structural & Footing details
- Drawings show design intent. Any changes to specification which affects design intent must be approved by the SCRC Project Representative.
- All structural members, fixings and/or footings to be confirmed by sign maker's engineer.
- Signmaker to confirm all details for approval on shop drawings prior to manufacture.

Construction Details

1. Fabricated 75 x 75 x 6mm mild steel SHS internal frame with fully welded 8mm thick plate and 16mm thick base plate. Provide steel skirt around base of sign to conceal post. Ground weld smooth. Galvanised finish.
2. 140 x 70mm thick dressed Class 2 min. timber hardwood panels, profiled to suit internal frame. Hardwood panels mechanically fixed via galvanised bolts.
3. 3mm thick fabricated aluminium sign panel with folded return. 2 pac painted or powdercoated to all visible sides with anti-graffiti spray clear coat finish all over.
4. Directional graphics
 Front applied vinyl graphics with 2 pac satin finish, anti-graffiti spray clear coat over.
5. 12 x 12mm aluminium angle to follow panel profile. Pin fixed to back of sign panel. Drill out holes to access split batten for removal.
6. Screw fix Signlink HD2 split batten aluminium extrusion to timber. Ensure track is spaced off evenly to allow sign face to locate and slide onto tracks.
7. Sign face to mount to split batten and mechanically fixed via grub screw.
8. Reinforced concrete pad/pier footing to signmakers' engineer specification. All fixings shall be below ground level to reduce trip hazards. Re-instate / make good paving or pavement, with no changes of level greater than 3mm and no gradients steeper than 1:40.

Elevations
 Scale 1:20

Mounting Detail
 Scale 1:2

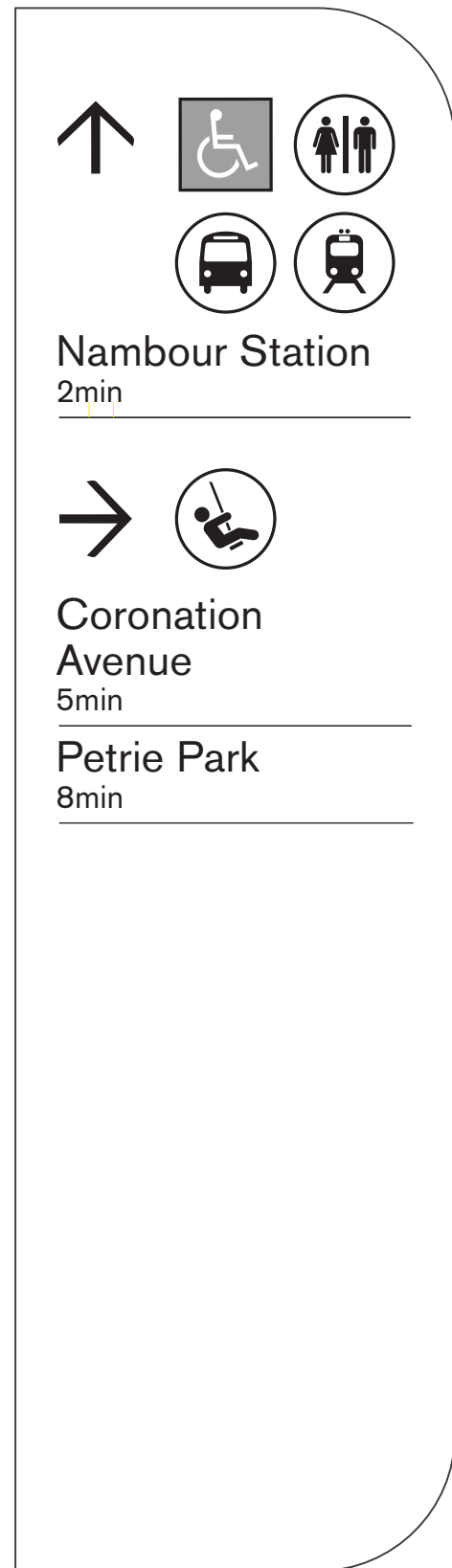

Typical Graphic Detail
 Scale 1:5

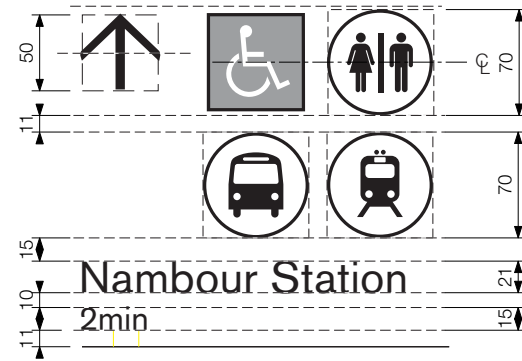

MESSAGE, ARROW & PICTOGRAM

Typical Graphic Detail
 Scale 1:5

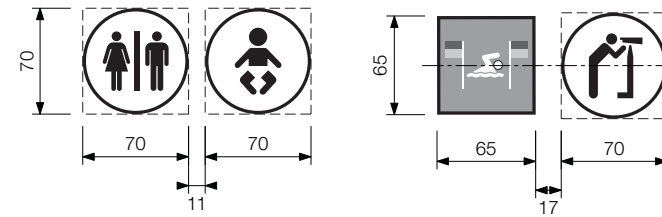

PICTOGRAM RELATIONSHIPS

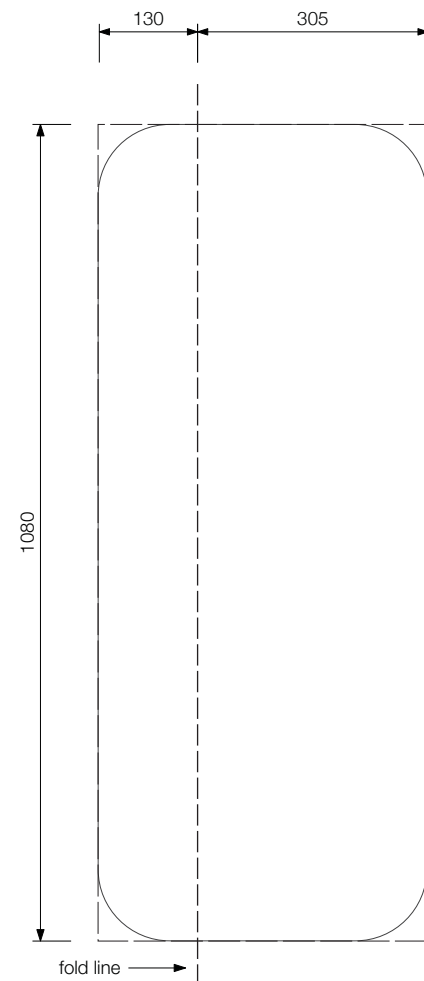

PANEL SHAPE

Typical Graphic Detail
 Scale 1:10

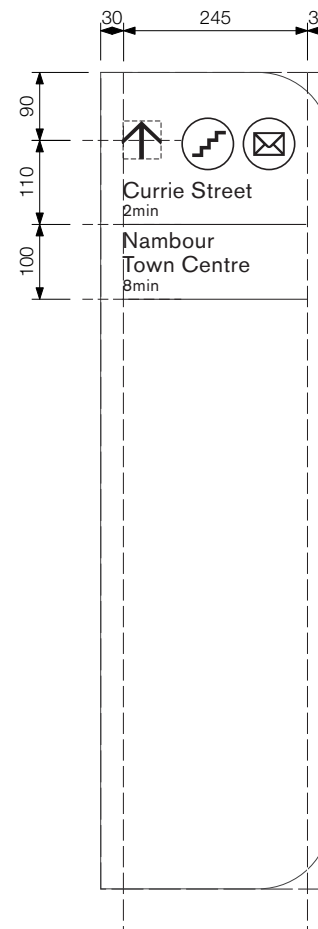

FRONT VIEW

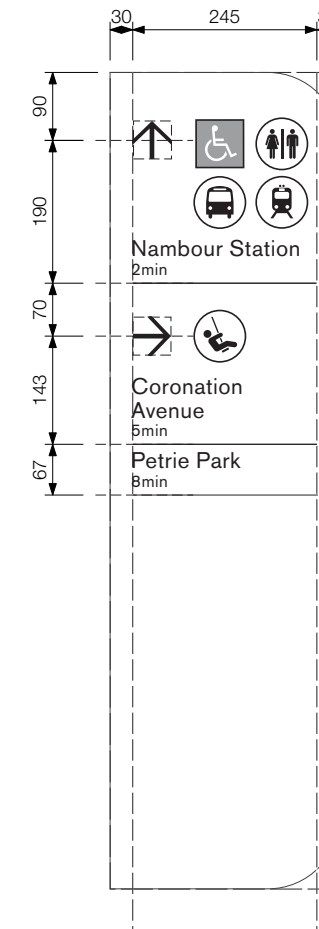

BACK VIEW

GENERAL CONSTRUCTION NOTES

- Refer to sheet 1 for General arrangement
- Refer to sheet 2 for Construction details
- Refer to sheet 4 for Structural & Footing details

Graphic Details

FONT
 All text = Berthold Akzidenz Grotesk Regular

COLOUR
 Sign panel background = Dulux Woodland Grey®
 Directional message = Avery White
 Pictograms - Refer to Pictogram standards for details

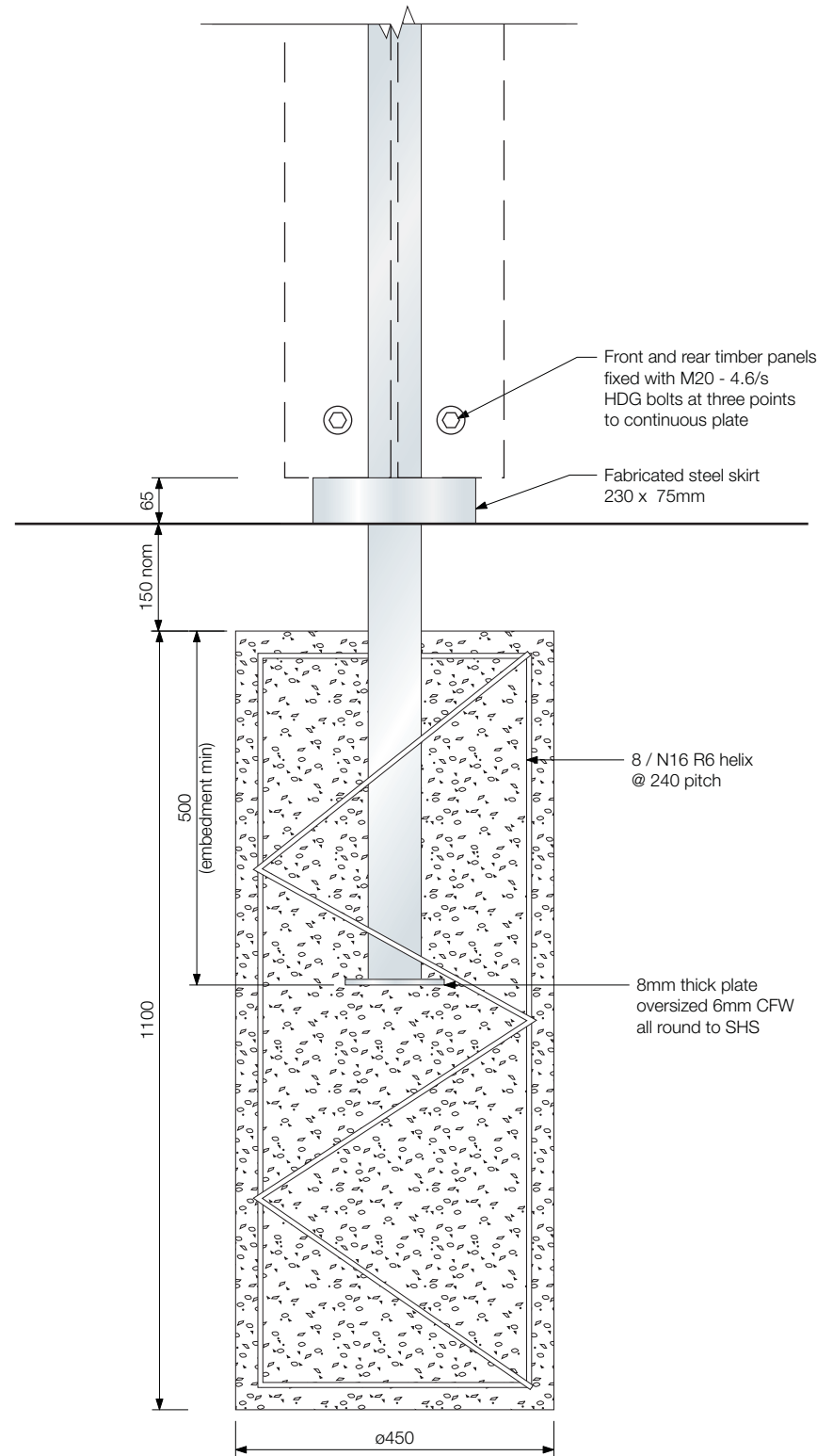

Pier footing

Direct Embed Footing Detail

Scale 1:10

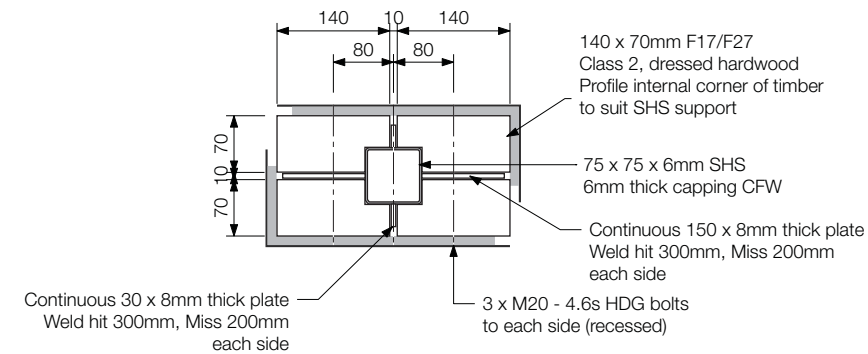

Section A (Sheet 2)

Scale 1:10

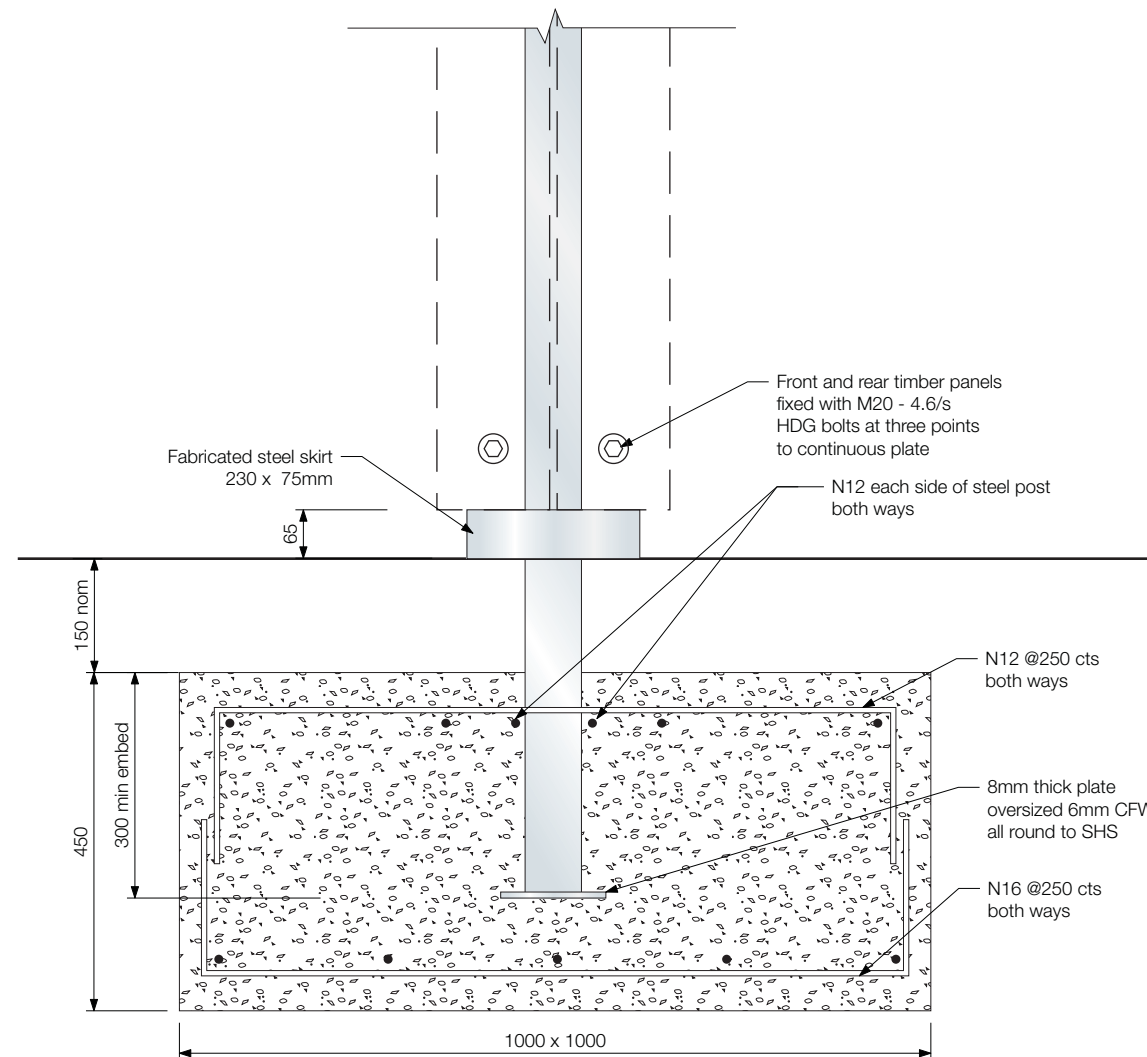

Pad footing

GENERAL CONSTRUCTION NOTES

- Refer to sheet 1 for General Arrangement
- Refer to sheet 2 for Construction details
- Refer to sheet 3 for Graphic details

Note

- Specifications shown are for preliminary advice only.
- All structural members, fixings and/or footings to be confirmed by sign maker's engineer.

Timber Specification

- All timber to be Minimum Class 2 F17/F27 hardwood
- Timber finish:
 1. Dressed / machined timber to specified size
 2. Tanalith E / ACQ Treatment
 3. CN oil finish top coat
 4. Treat with Tanacoat oil

GENERAL CONSTRUCTION NOTES

- Refer to sheet 2 for Construction details
- Refer to sheet 3 for Graphic layout details
- Refer to sheet 4 for Above ground install
- Refer to sheet 5 for Direct embed install

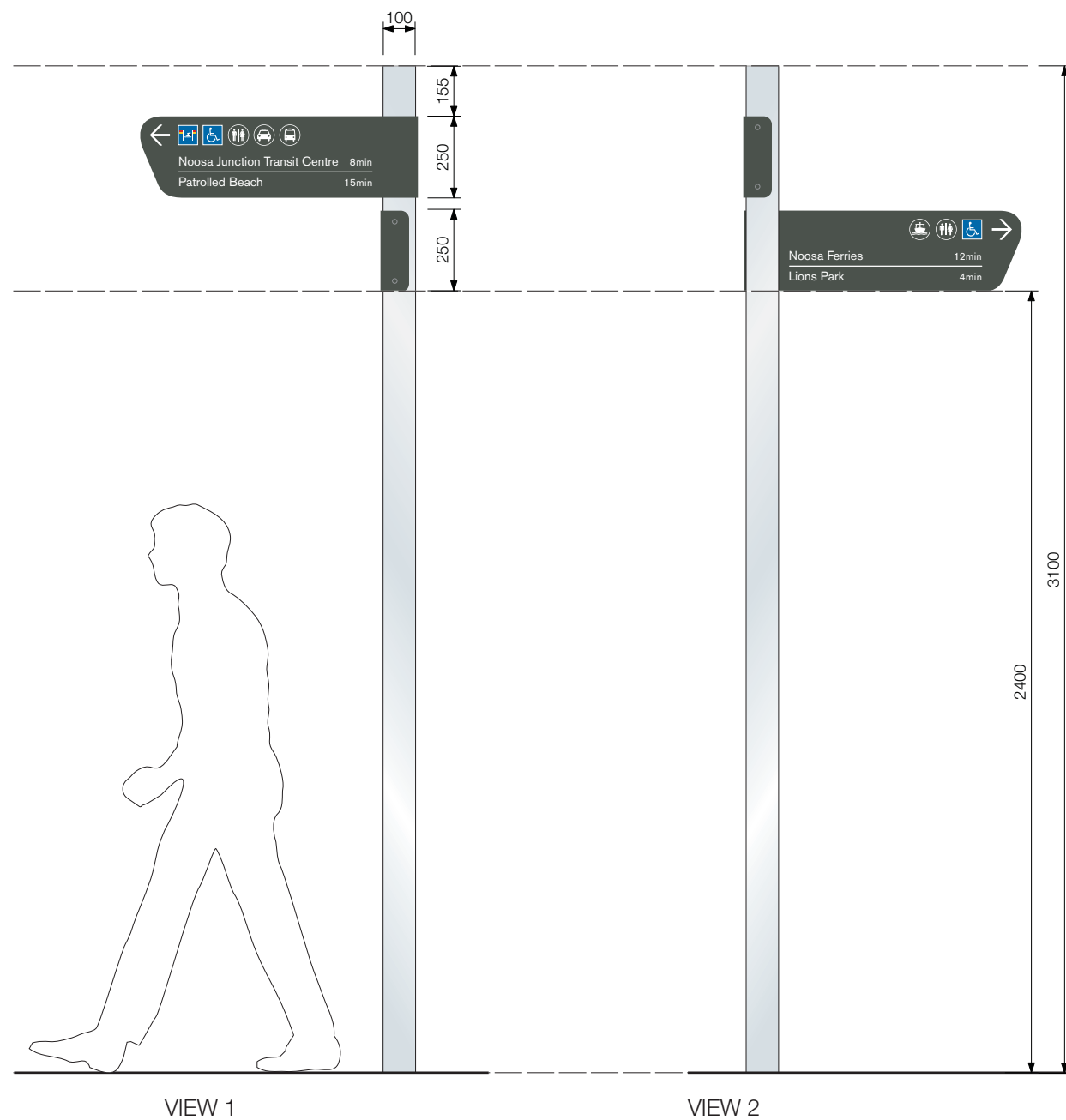

Elevations

Scale 1:20

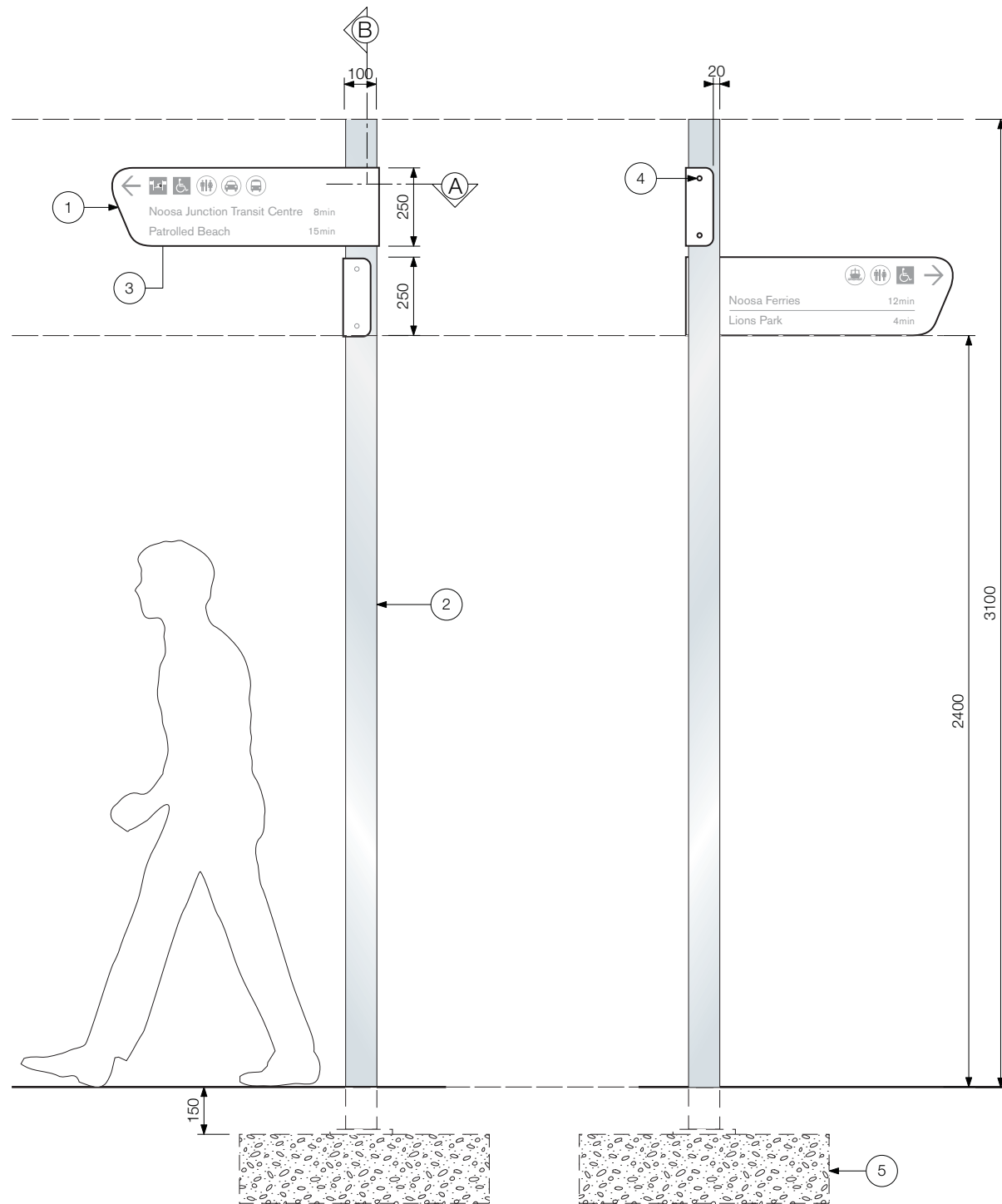

VIEW 1

VIEW 2

Elevations

Scale 1:20

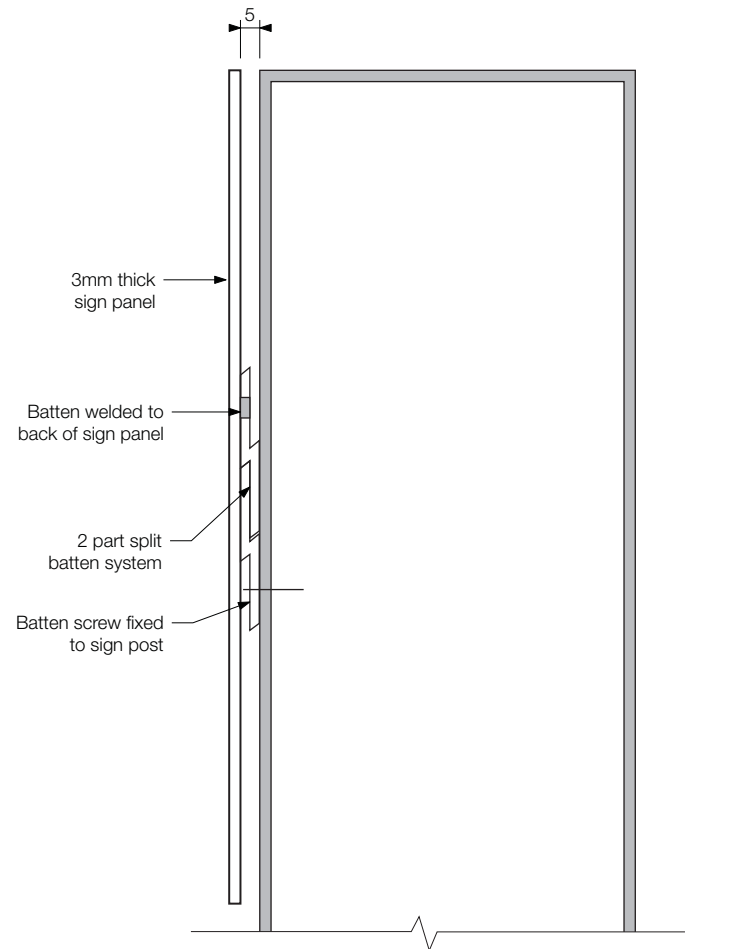

Section B

Scale 1:2

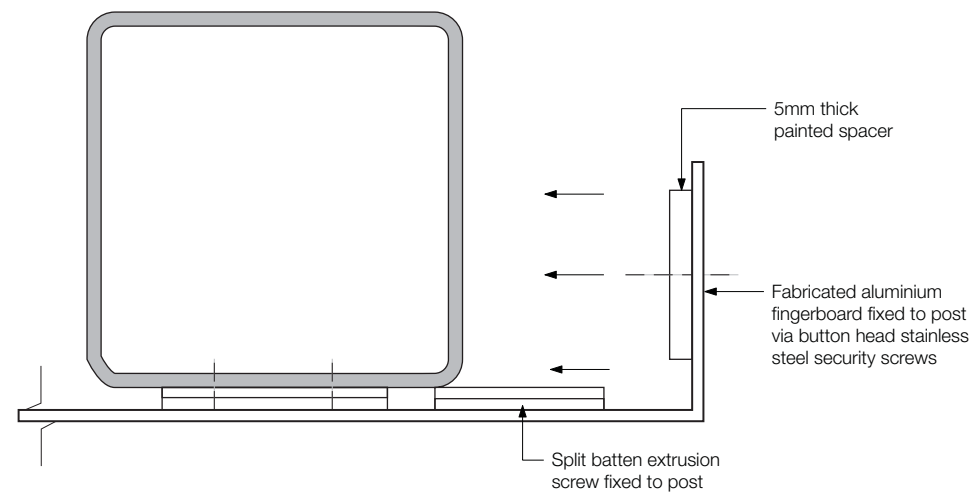

Section A

Scale 1:2

GENERAL CONSTRUCTION NOTES

- Refer to sheet 1 for General arrangement
- Refer to sheet 3 for Graphic layout details
- Refer to sheet 4 for Above ground install
- Refer to sheet 5 for Direct embed install
- Drawings show design intent. Any changes to specification which affects design intent must be approved by the SCRC Project Representative.
- All structural members, fixings and/or footings to be confirmed by sign maker's engineer.
- Signmaker to confirm all details for approval on shop drawings prior to manufacture.

Construction Details

1. 3mm thick fabricated aluminium sign panel with folded return. 2 pac painted or powdercoated to all visible sides, anti-graffiti clear spray coat finish all over. Fix 5mm thick spacer to panel edge.
2. 100 x 100 x 3.5mm SHS grade 350 post with fully welded base plate and 6mm thick capping. 6mm CFW 220 x 220 x 16mm thick base plate. Galvanised finish.
3. Front applied vinyl graphics with 2 pac satin finish, anti-graffiti spray clear coat over.
4. Sign panel fixed to post via security fixings. Post hexagon Socket countersunk head machine stainless steel fixing on return edge. Signlink Split Batten LB to provide a support to post. Refer detail.
- 5.a FOOTING OPTION 1 - BELOW GROUND
 Footing to be 150mm nominal to coordinate with paving. Reinforced concrete pad/pier footing to signmakers' engineer specification. All fixings shall be below ground level to reduce trip hazards. Re-instate / make good paving or pavement, with no changes of level greater than 3mm and no gradients steeper than 1:40.
- 5.b. FOOTING OPTION 2 - ABOVE GROUND
 Mechanical anchors to existing concrete slab. Leveling grout as required. Fixing via M12 hold down bolts with stainless steel dome head nuts. Site inspection to confirm suitability of slab prior to installation.

Material Finish

- Panel paint finish = Satin finish
- Steel post = Galvanised finish

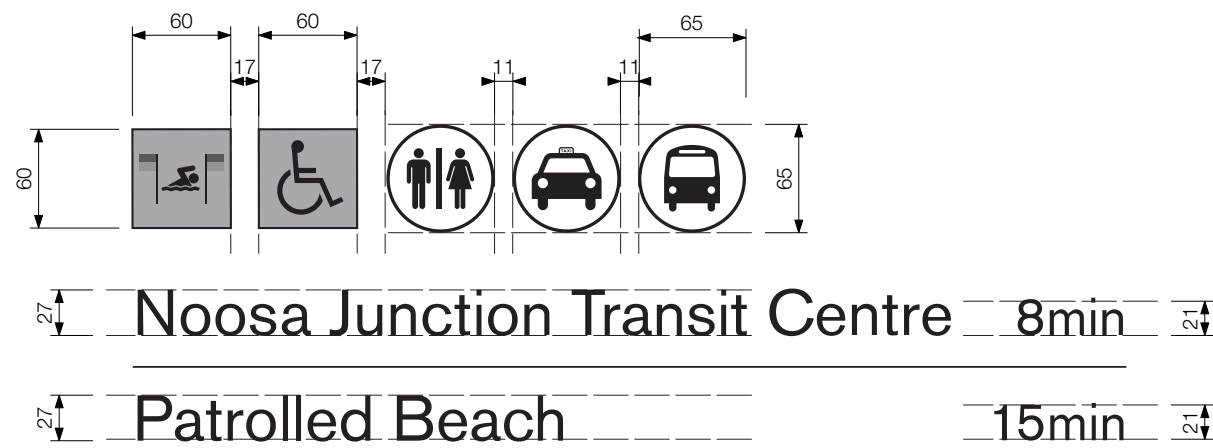

GENERAL CONSTRUCTION NOTES

- Refer to sheet 1 for General arrangement
- Refer to sheet 2 for Construction details
- Refer to sheet 4 for Above ground install
- Refer to sheet 5 for Direct embed install

Graphic Details

FONT

All text = Berthold Akzidenz Grotesk Regular

COLOUR

Sign panel background = Dulux Woodland Grey®

Directional message = Avery White

Pictograms - Refer to Pictogram standards for details

Typical Graphic Layout

Scale 1:5

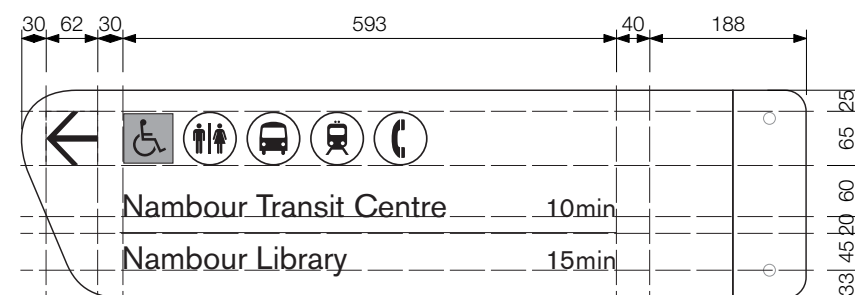
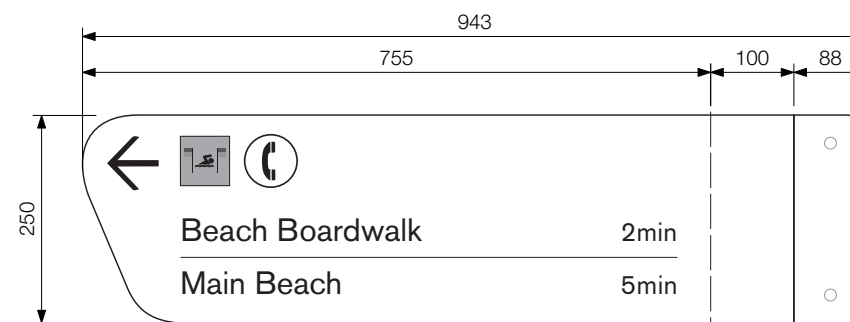
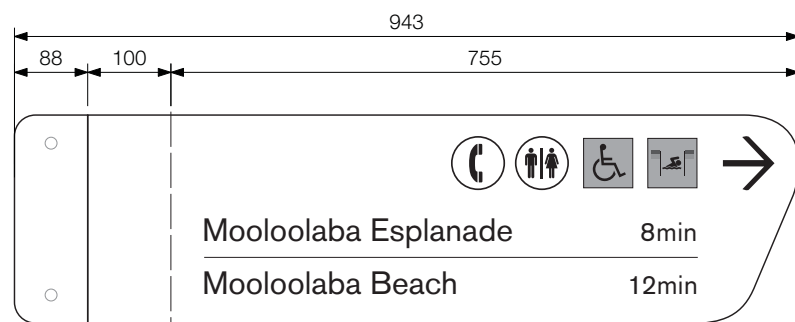

RIGHT DIRECTION

LEFT DIRECTION

GENERAL CONSTRUCTION NOTES

- Refer to sheet 1 for General Arrangement
- Refer to sheet 2 for Construction details
- Refer to sheet 3 for Graphic details
- Refer to sheet 5 for Direct embed footings

Note

- Specifications shown are for preliminary advice only.
- All structural members, fixings and/or footings to be confirmed by sign maker's engineer.

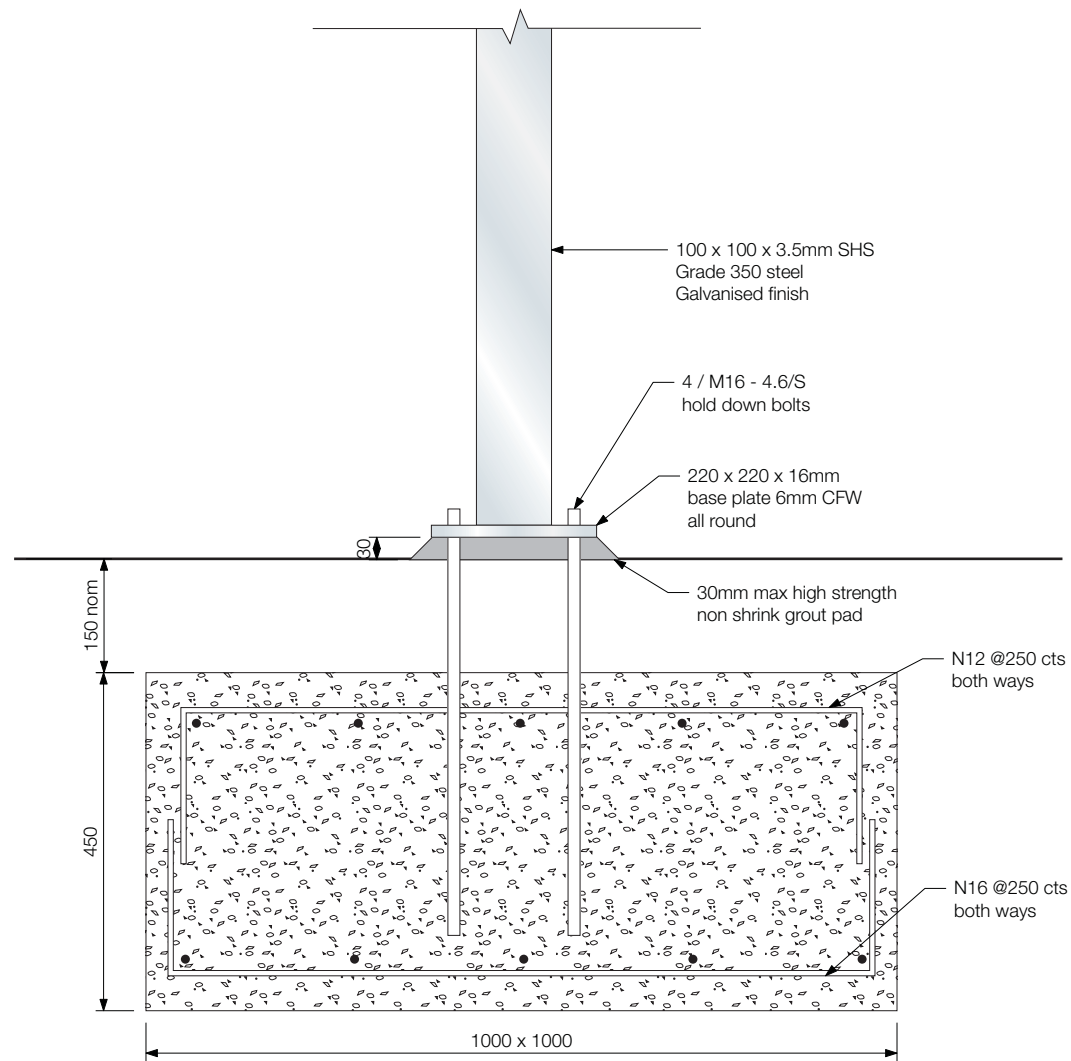

Option 1 - Pad footing

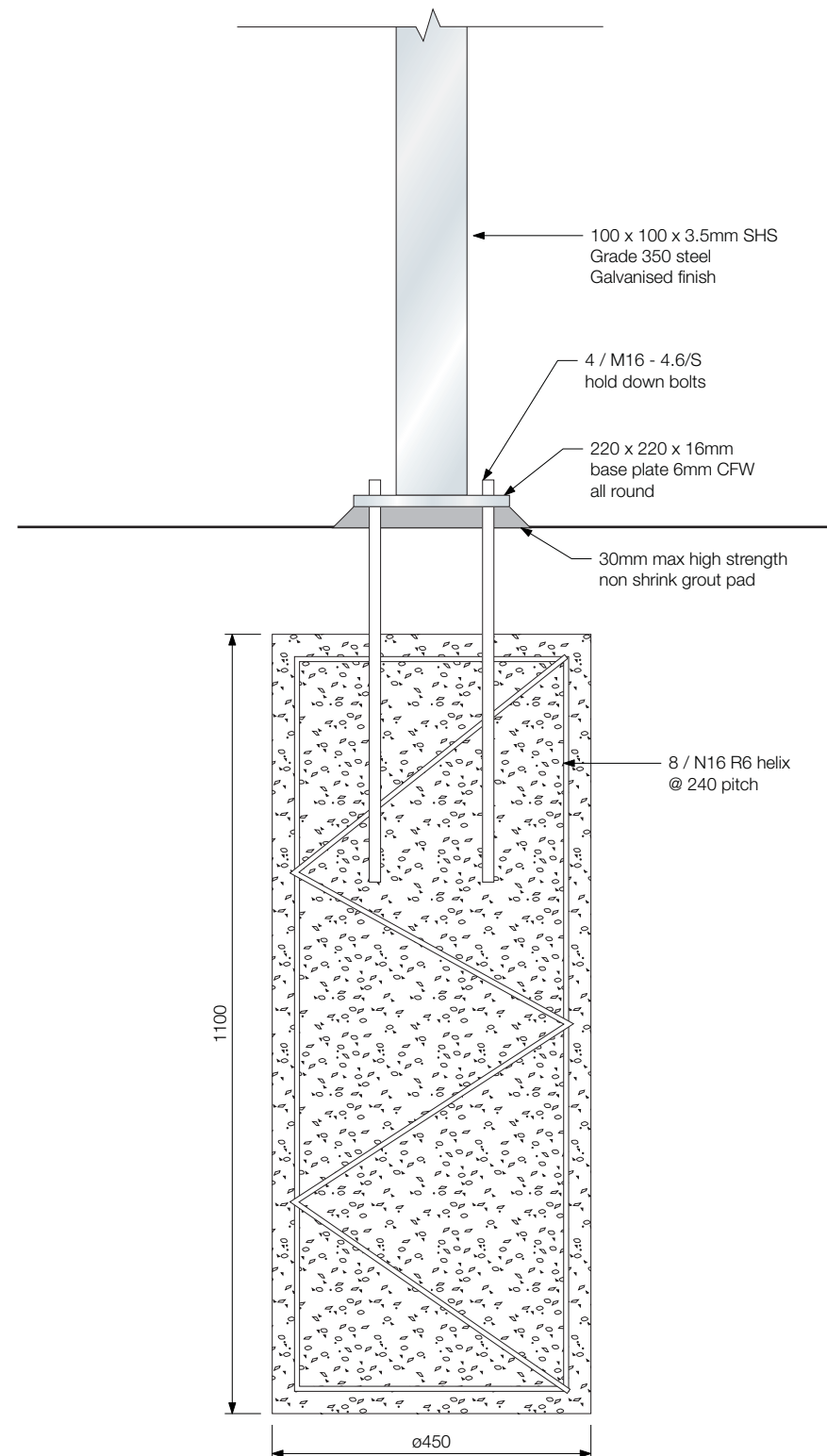

Option 2 - Pier footing

Above Ground Footing Detail

Scale 1:10

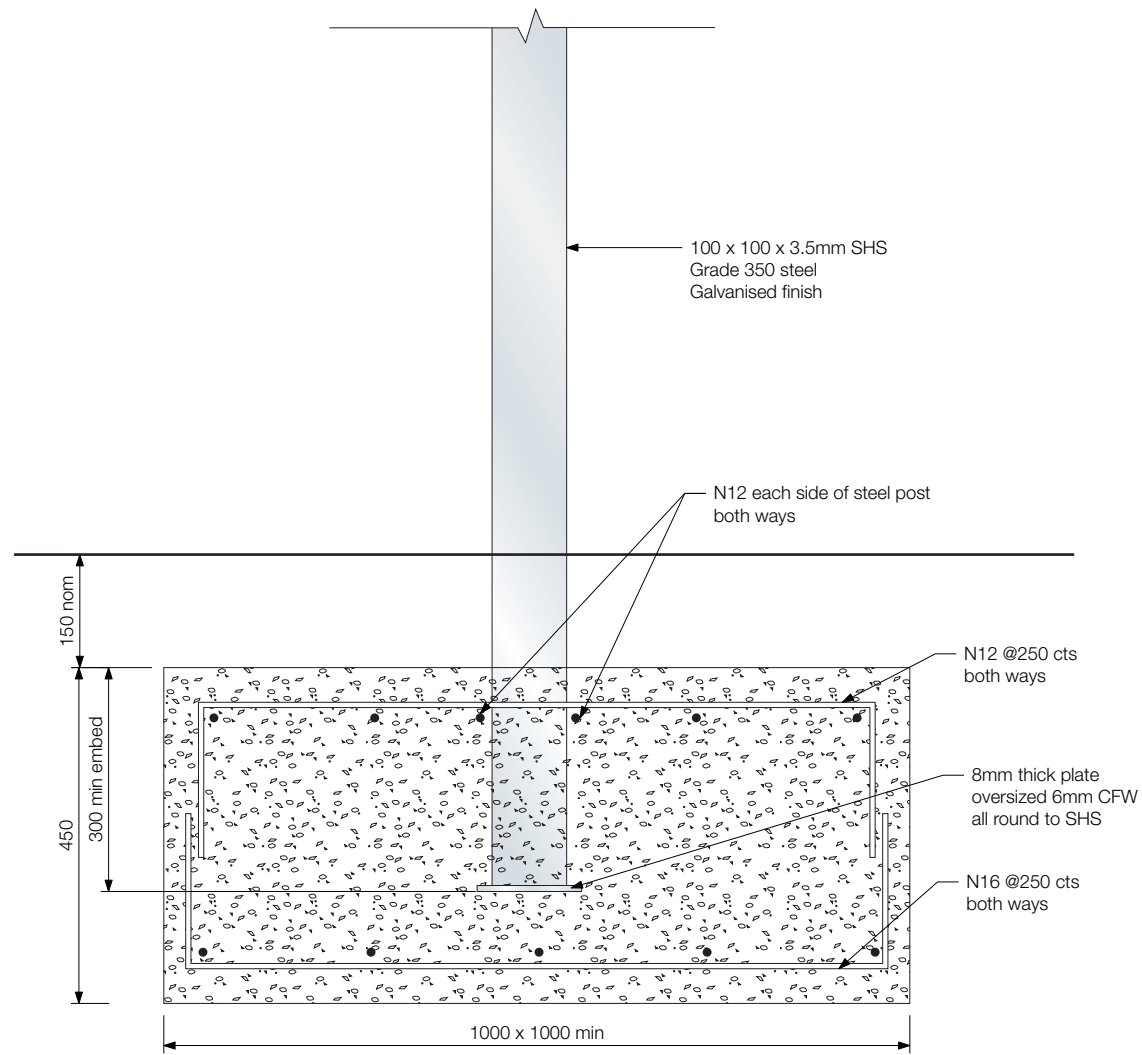

Option 1 - Pad footing

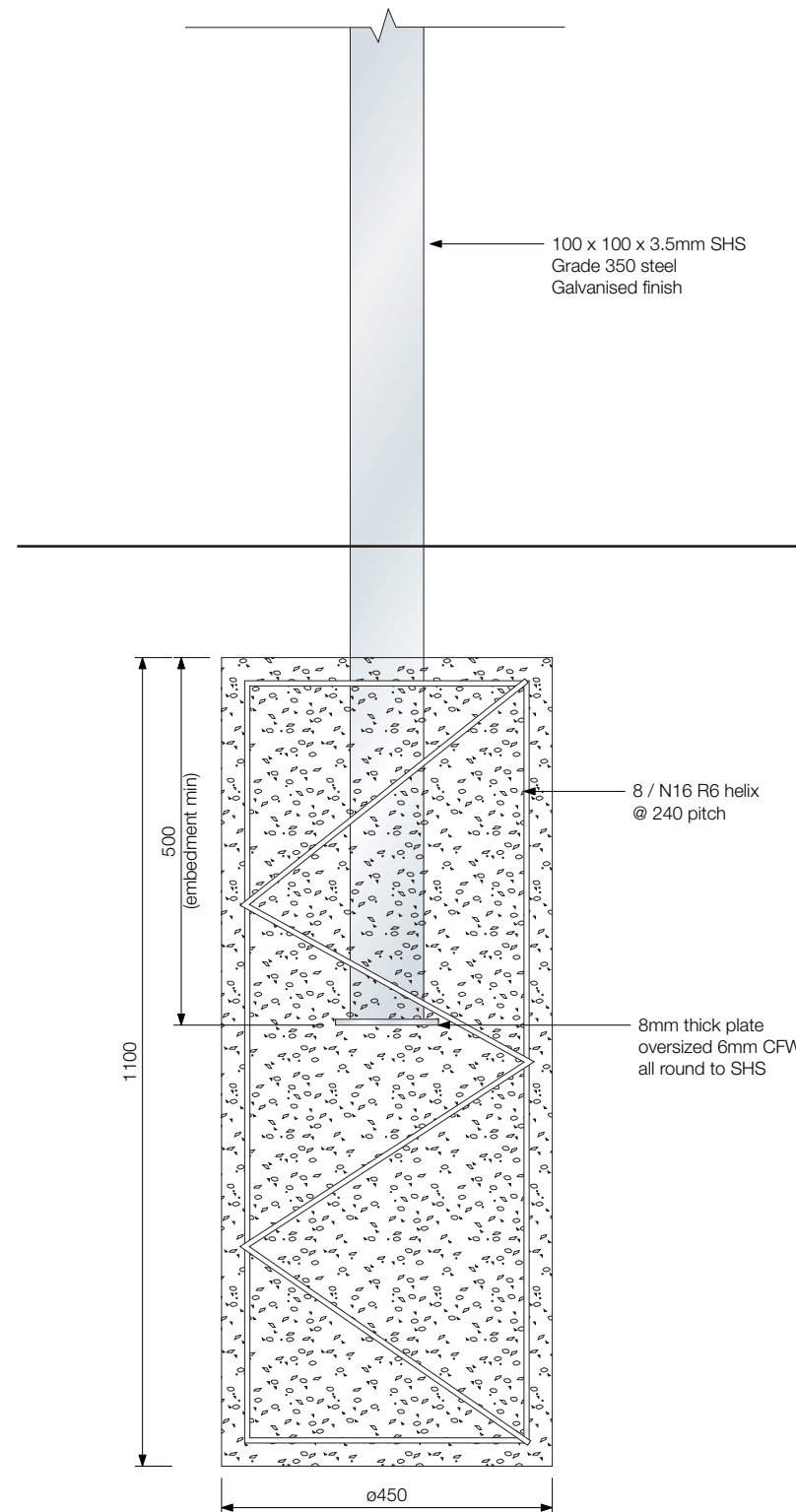

Option 2 - Pier footing

GENERAL CONSTRUCTION NOTES

- Refer to sheet 1 for General Arrangement
- Refer to sheet 2 for Construction details
- Refer to sheet 3 for Graphic details
- Refer to sheet 4 for Above ground footings

Note

- Specifications shown are for preliminary advice only.
- All structural members, fixings and/or footings to be confirmed by sign maker's engineer.

Direct Embed Footing Detail

Scale 1:10

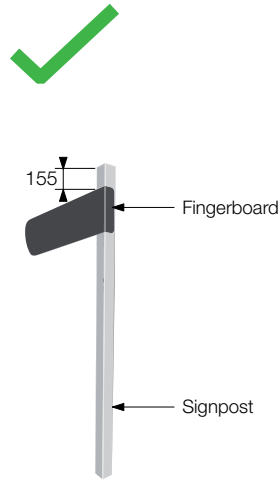

Single Fingerboard

Single directional fingerboard can point in any direction but top edge of fingerboard must be located 155mm from top of sign post

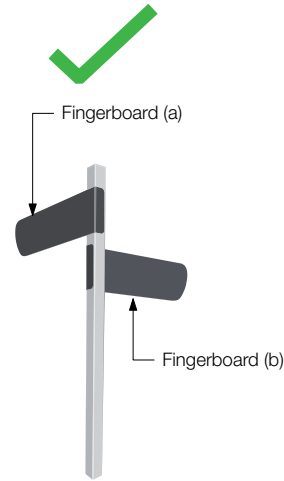

Two Fingerboards 90°

If there are two sign fingerboards at 90° to each other (a) (b), fingerboard (b) is located under fingerboard (a)

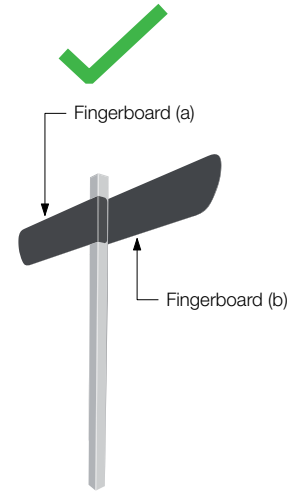

Two Fingerboards 180°

If there are two sign fingerboards at 90° to each other (a) (b), fingerboard (b) is located under fingerboard (a)



Three Fingerboards

A three directional layout always has two sign fingerboards sitting above a single fingerboard



Four Fingerboards

A four fingerboard sign has two fingerboards (180° to each other) at the top of the sign post and another two (180° to each other) underneath

GENERAL CONSTRUCTION NOTES

- Refer to sheet 1 for General Arrangement
- Refer to sheet 2 for Construction details
- Refer to sheet 3 for Graphic details
- Refer to sheet 4 for Above ground footings
- Refer to sheet 5 for Direct embed footings

ALLOWED

Correct application for Directional Fingerboards



Single Fingerboard

The top edge of the single fingerboard should not sit lower than 155mm from the top edge of the sign post.



Two Fingerboards 90°

Two fingerboards at 90° should not sit on the same level



Two Fingerboards 180°

Two fingerboards at 180° should not sit on different levels



Three Fingerboards

A single fingerboard must not sit above two other fingerboards in a three directional layout



Four Fingerboards

Fingerboards should not sit 90° from each other on the same level

NOT ALLOWED

This configuration is not allowed and will not be accepted.

GENERAL CONSTRUCTION NOTES

- Refer to sheet 2 for Construction details
- Refer to sheet 3 for Graphic layout details
- Drawings show design intent. Any changes to specification which affects design intent must be approved by the SCRC Project Representative.
- All structural members, fixings and/or footings to be confirmed by sign maker's engineer.
- Signmaker to confirm all details for approval on shop drawings prior to manufacture.

Graphic Details

FONT

All text = Berthold Akzidenz Grotesk Regular

COLOUR

Sign panel background = Dulux Woodland Grey®

Directional message = Avery White

Pictograms - Refer to Pictogram standards for details

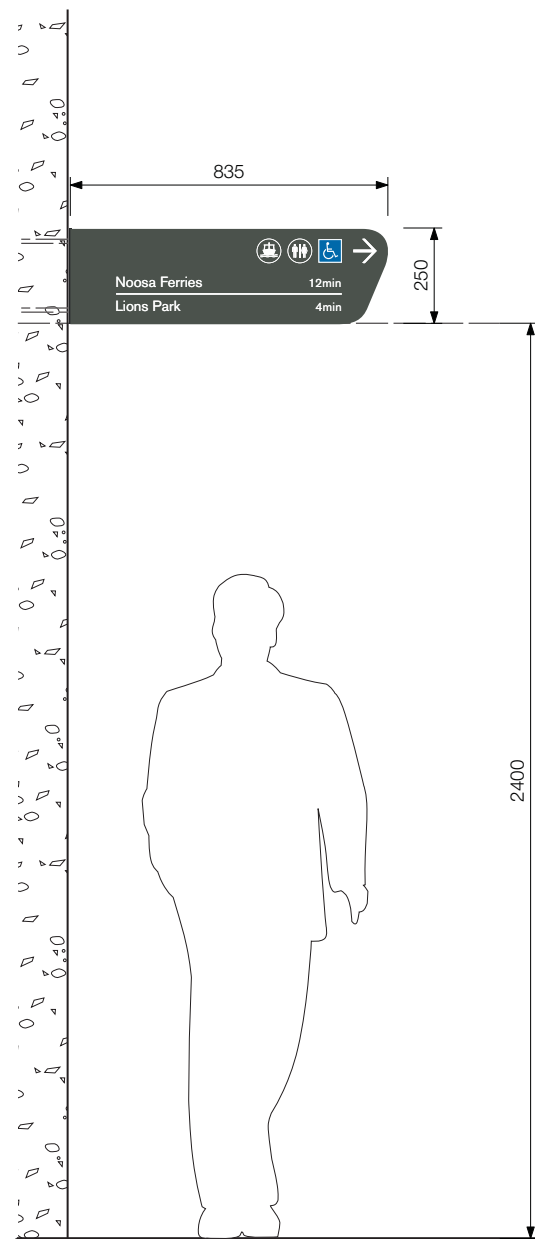

FRONT VIEW

FIXED TO WALL / BUILDING



FRONT VIEW

MOUNTED TO EXISTING POST

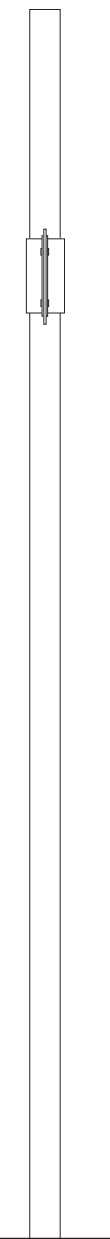

SIDE VIEW

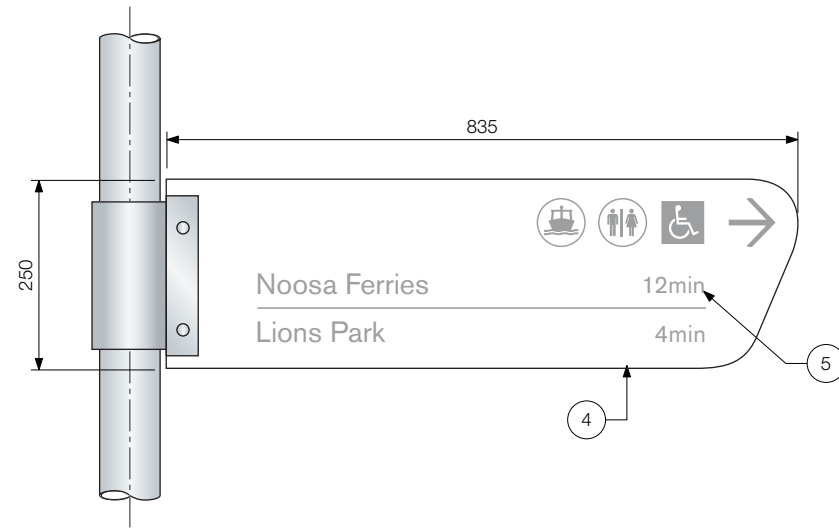

FRONT VIEW
 MOUNTED TO EXISTING POST

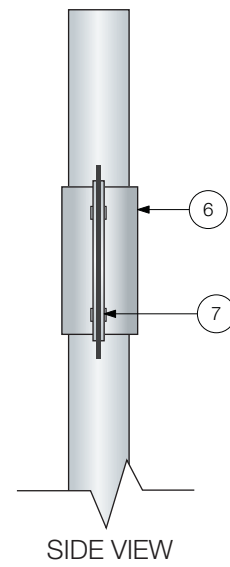

SIDE VIEW

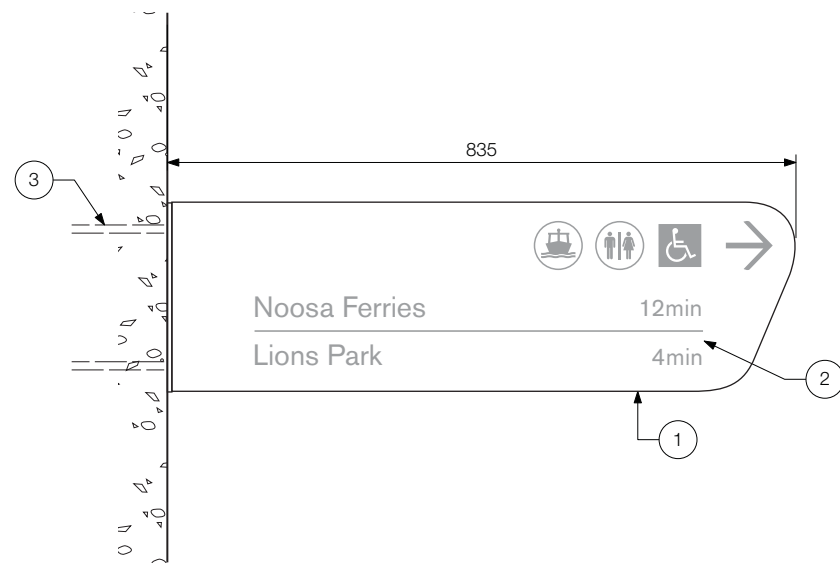

FRONT VIEW
 FIXED TO WALL / BUILDING

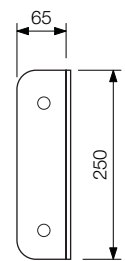

SIDE VIEW

GENERAL CONSTRUCTION NOTES

- Refer to sheet 1 for General arrangement
- Refer to sheet 3 for Graphic layout details
- Drawings show design intent. Any changes to specification which affects design intent must be approved by the SCRC Project Representative.
- All structural members, fixings and/or footings to be confirmed by sign maker's engineer.
- Signmaker to confirm all details for approval on shop drawings prior to manufacture.

Construction Details

Wall mounted projecting sign

1. 3mm thick fabricated aluminium sign panel with folded return. 2 pac painted or powdercoated to all visible sides, anti-graffiti clear spray coat finish all over.
2. Front applied vinyl graphics with 2 pac satin finish, anti-graffiti spray clear coat over.
3. Sign panel fixed to wall via suitable mechanical anchor. 2 x M12 Chemset anchors, 120mm min embed. Provide neoprene washer between panel and wall.

Existing post mounted projecting sign

4. 3mm thick aluminium sign panel. 2 pac painted to all visible sides, anti-graffiti clear spray coat finish all over.
5. Front applied vinyl graphics with 2 pac satin finish, anti-graffiti spray clear coat over.
6. Sign panel fixed to post via two-part, slide and lock system aluminium bracket.
 - 7a. Option 1
 BR-8-A Appleton clamp to suit 50mm NB post and wide panel. 2 x M8 x 20mm Zincplated Hex Head bolts and nuts post fixings.
 - 7b. Option 2 - Clampon anti-theft
 BR-121-A Appleton clamp to suit 50mm NB post and wide panel. Anti-theft fixings.

Material Finish

Panel paint finish = Satin finish
 Clamp = Mill finish aluminium

Elevations

Scale 1:10

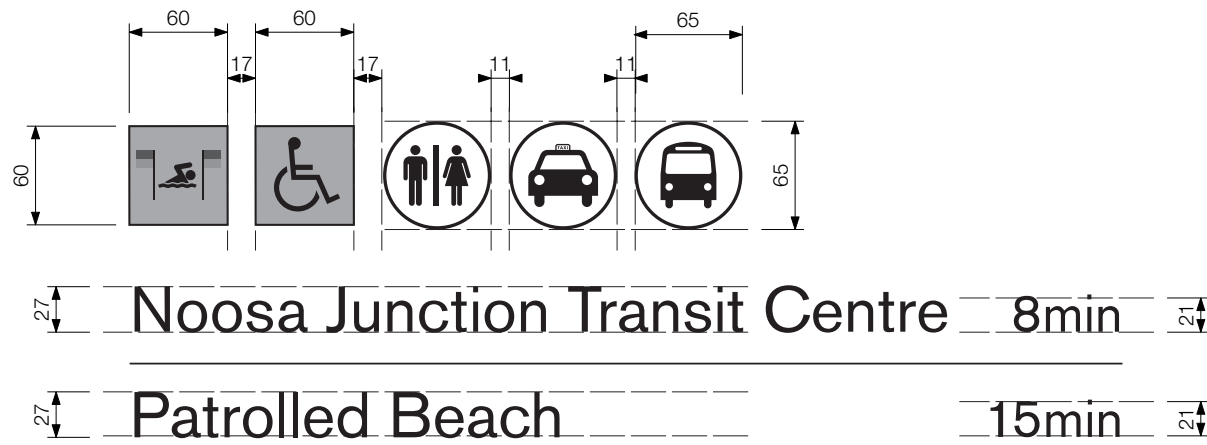

GENERAL CONSTRUCTION NOTES

- Refer to sheet 1 for General Arrangement
- Refer to sheet 2 for Construction details

Graphic Details

FONT
 All text = Berthold Akzidenz Grotesk Regular

COLOUR
 Sign panel background = Dulux Woodland Grey®
 Directional message = Avery White
 Pictograms - Refer to Pictogram standards for details

Typical Graphic Layout

Scale 1:5

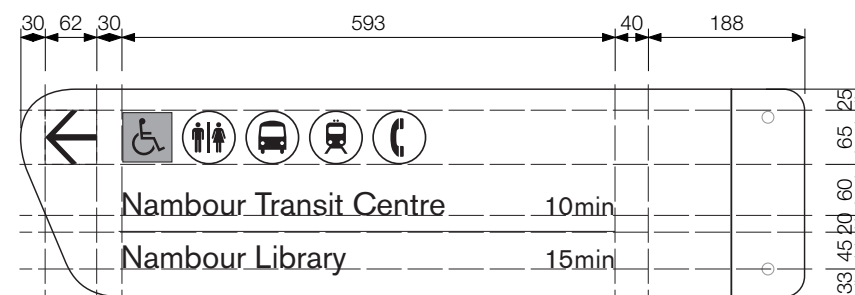
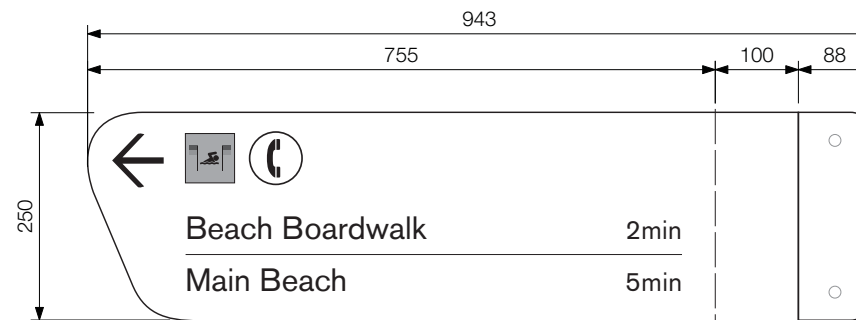
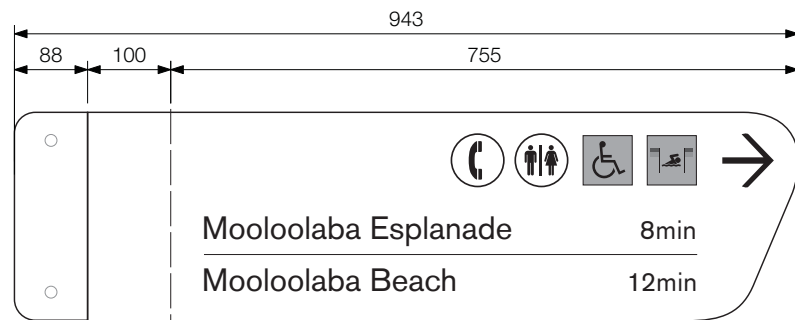

RIGHT DIRECTION

LEFT DIRECTION



PATHWAY SUITE 3

Pathway Network

Sign Suite Summary

Sign Type 3.1 – Distance Marker Sign Freestanding

Sign Type 3.2 – Distance Marker Sign Surface Plate

Sign Type 3.3 – Distance Marker Sign Stencil

Sign Type 3.4 – Directional Bollard Sign Freestanding

Sign Type 3.5 – Street and Road Direction Stencil

Sign Type 3.6 – Street and Road Identification Stencil & Surface Plate

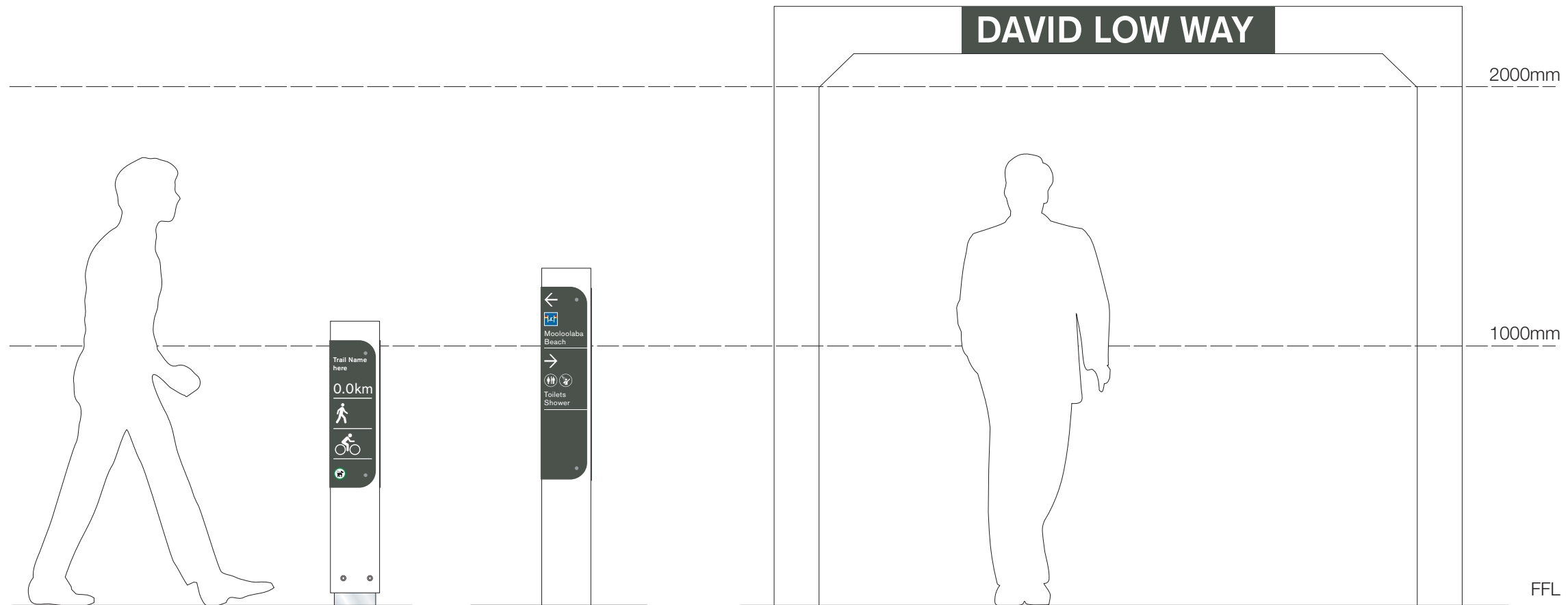

3.1
Distance Marker Sign Freestanding

3.4
Directional Bollard Sign Freestanding

3.6
Street and Road Identification Stencil & Surface Plate

SUITE 3 SIGN SUMMARY

- Sign Type 3.1 – Distance Marker Sign Freestanding
- Sign Type 3.2 – Distance Marker Sign Surface Plate
- Sign Type 3.3 – Distance Marker Sign Stencil
- Sign Type 3.4 – Directional Bollard Sign Freestanding
- Sign Type 3.5 – Street and Road Direction Stencil
- Sign Type 3.6 – Street and Road Identification Stencil and Surface Plate

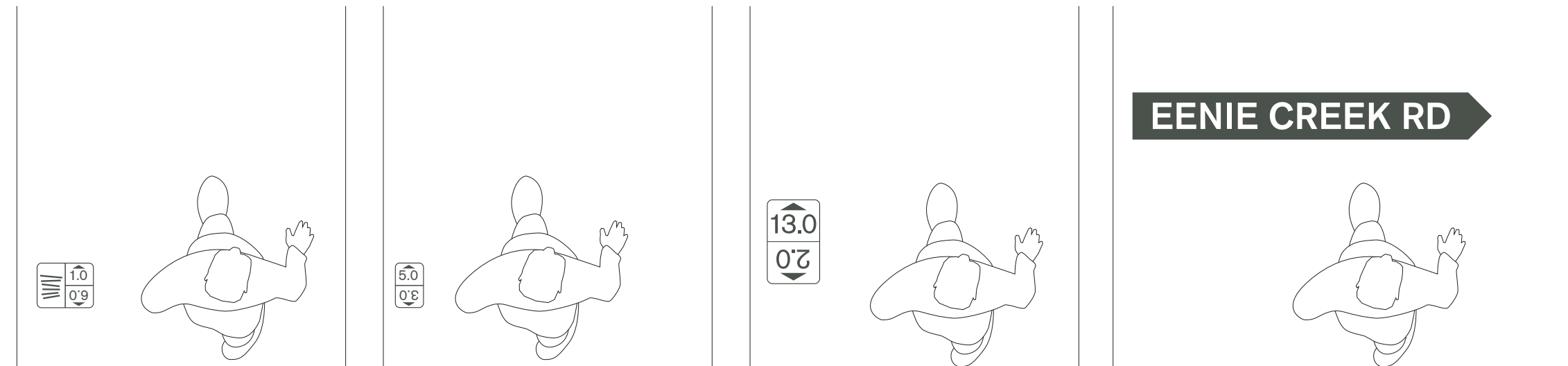

3.2
Distance Marker Sign Surface Plate
Distance Only & Brand/Logo

3.2
Distance Marker Sign Surface Plate
Distance Only

3.3
Distance Marker Sign Stencil

3.5
Street and Road Direction Stencil

Elevations

Scale 1:20

GENERAL CONSTRUCTION NOTES

- Refer to sheet 2 for Construction / Structural details
- Refer to sheet 3 for Graphic Layouts

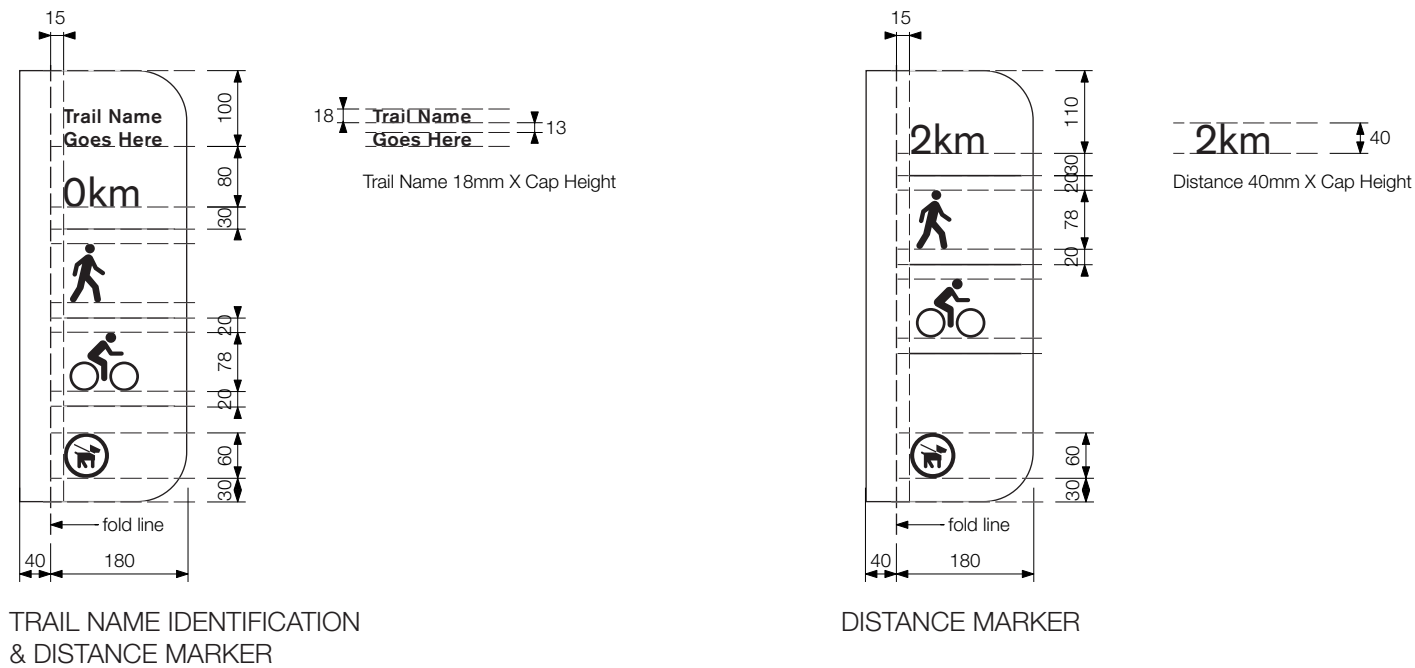

Typical Graphic Layout

Scale 1:10

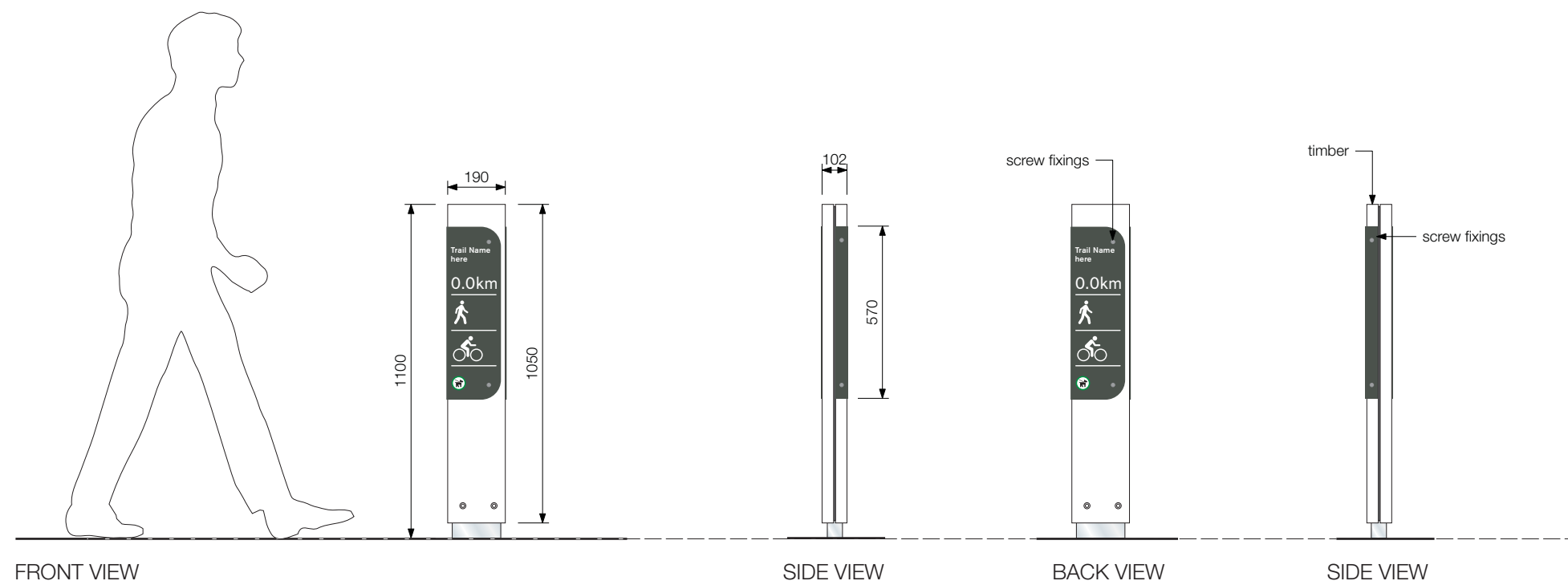

Elevations

Scale 1:20

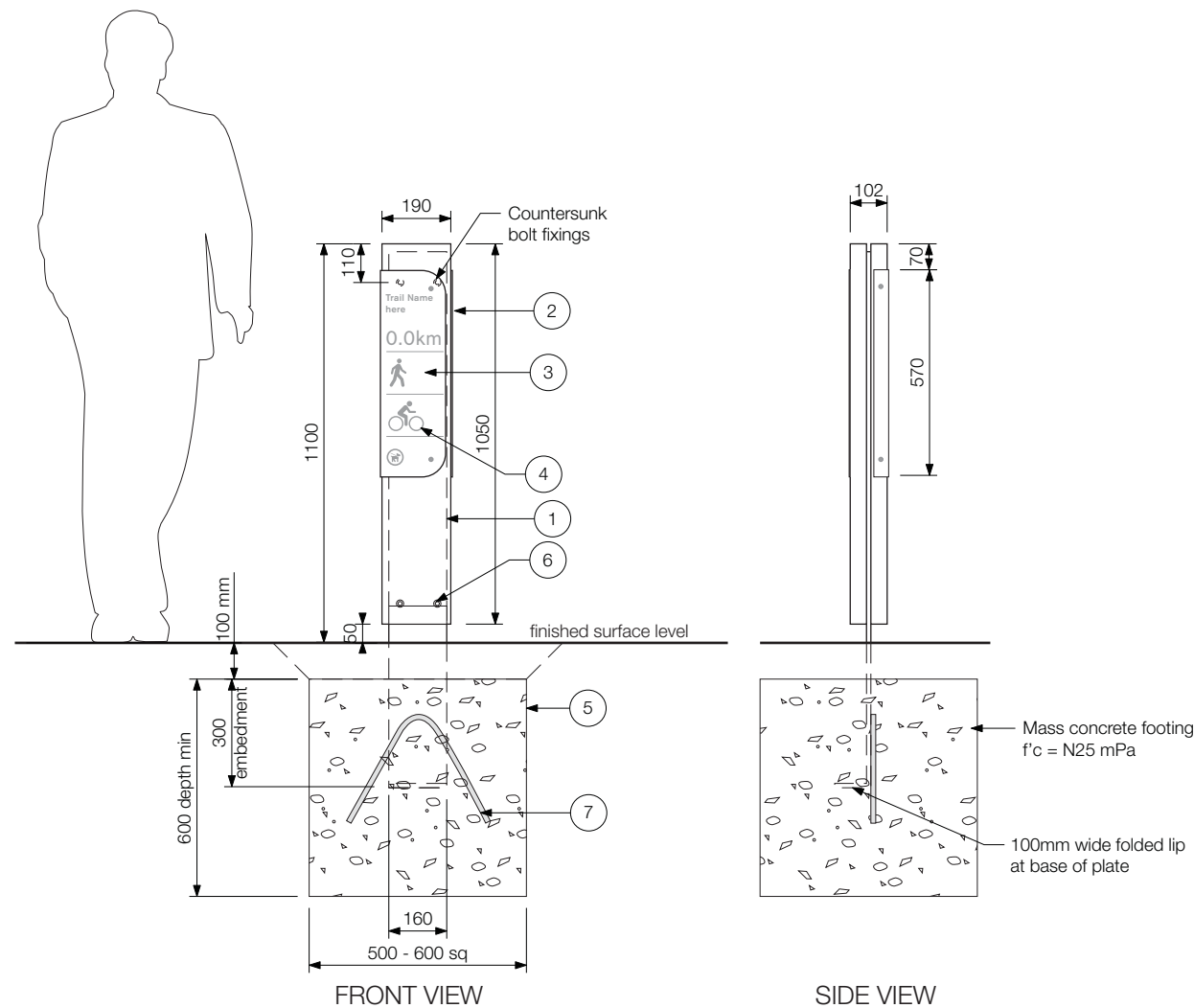
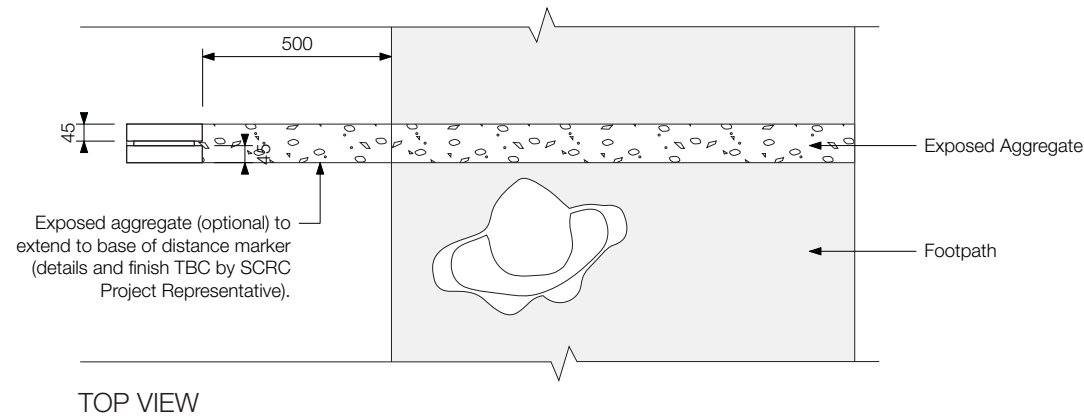

Elevations

Scale 1:20

GENERAL CONSTRUCTION NOTES

- Refer to sheet 1 for General arrangement details
- Refer to sheet 3 for Graphic Layouts
- Drawings show design intent. Any changes to specification which affects design intent must be approved by the SCRC Project Representative.
- All structural members, fixings and/or footings to be confirmed by sign maker's engineer.
- Signmaker to confirm all details for approval on shop drawings prior to manufacture.

Construction Details

1. 160 x 12mm hot dipped galvanised steel support with welded lug.
 2. 190 x 45mm F17/F27 hard wood. Hardwood panels mechanically fixed via galvanised bolts.
 3. 3mm thick fabricated aluminium sign panel with folded return. 2 pac painted or powdercoated to all visible sides, anti-graffiti clear spray coat finish all over. Post Torx socket button head self tapping screw fixed to timber.
 4. Front applied vinyl graphics with 2 pac satin finish, anti-graffiti spray clear coat over.
 5. FOOTING - DIRECT EMBED
- Reinforced concrete pad/pier footing to signmakers' engineer specification. All fixings shall be below ground level to reduce trip hazards. Re-instate / make good paving or pavement, with no changes of level greater than 3mm and no gradients steeper than 1:40.
6. 2 / M12- 4.6s HDG bolts top and bottom. Note that top bolts to be concealed behind sign panel.
 7. N12 x 700mm LUG welded to plate back (300 legs) 75mm concrete cover.

Material Finish

Panel paint finish = Satin finish
 Support frame = Galvanised finish

Timber Specification

- All timber to be Minimum Class 2 F17/F27 hardwood
- Timber finish:
 1. Dressed / machined timber to specified size
 2. Tanalith E / ACQ Treatment
 3. CN oil finish top coat
 4. Treat with Tanacoat oil

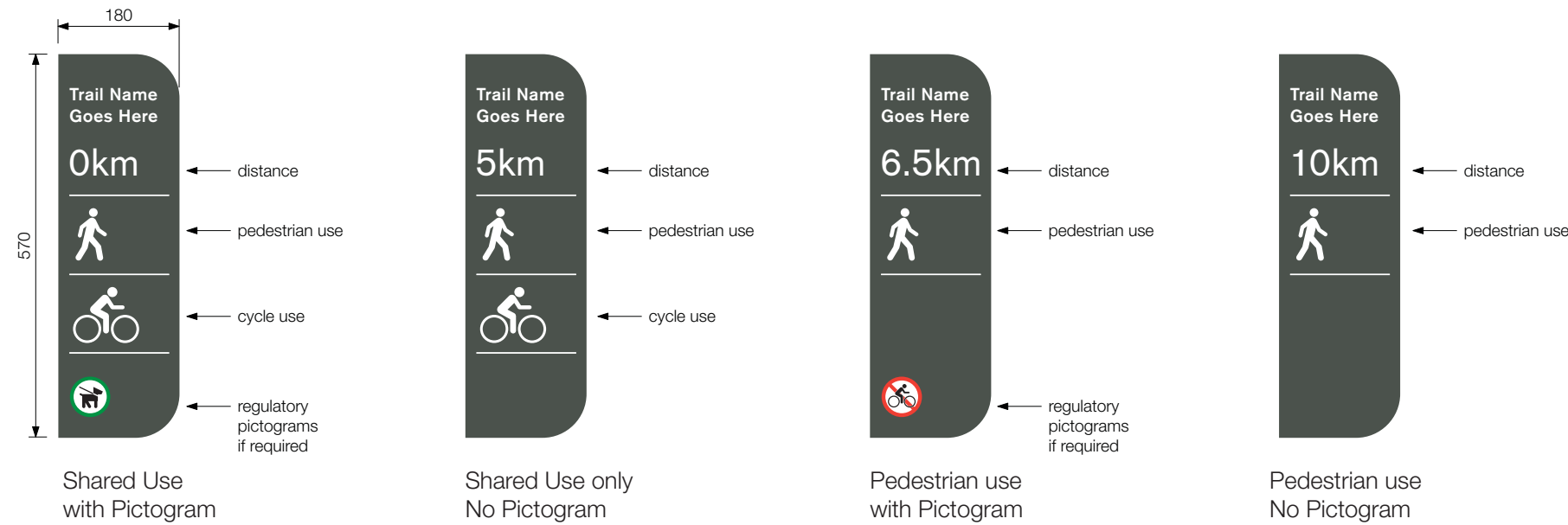

TRAIL NAME IDENTIFICATION & DISTANCE MARKER

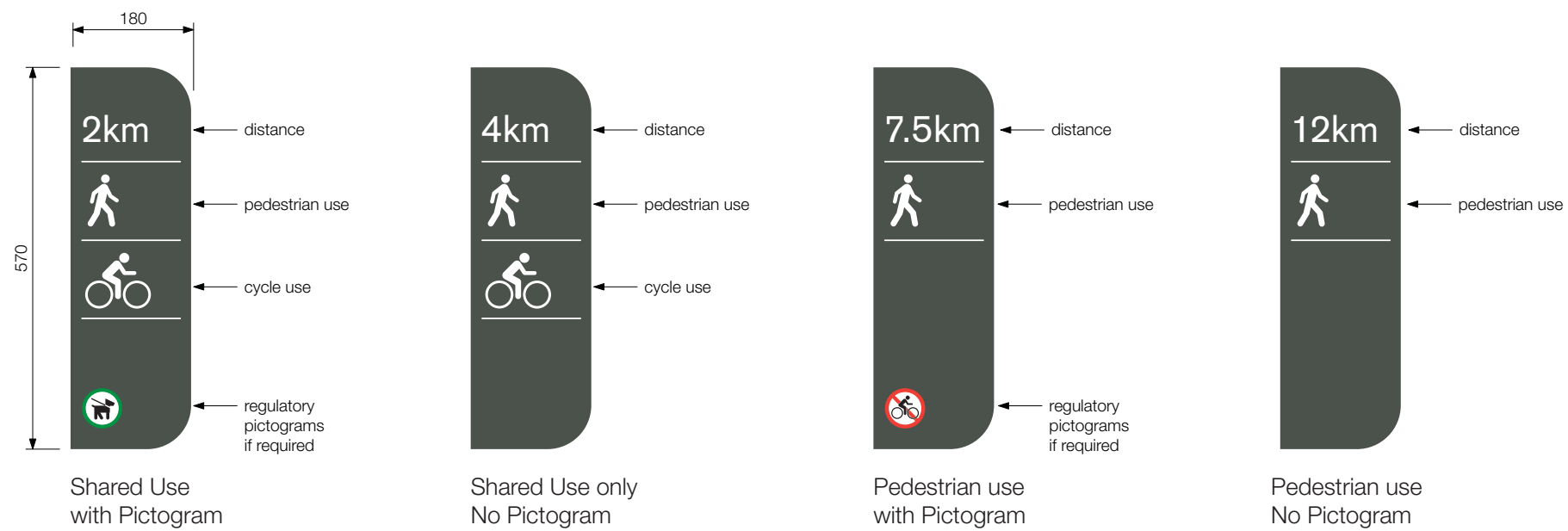

DISTANCE MARKER

Typical Graphics

Scale 1:10

GENERAL CONSTRUCTION NOTES

- Refer to sheet 1 for General arrangement
- Refer to sheet 2 for Construction / Structural details

Graphic Details

FONT

All text = Berthold Akzidenz Grotesk Regular

COLOUR

Sign panel background = Dulux Woodland Grey®

Directional message = Avery White

Pictograms - Refer to Pictogram standards for details

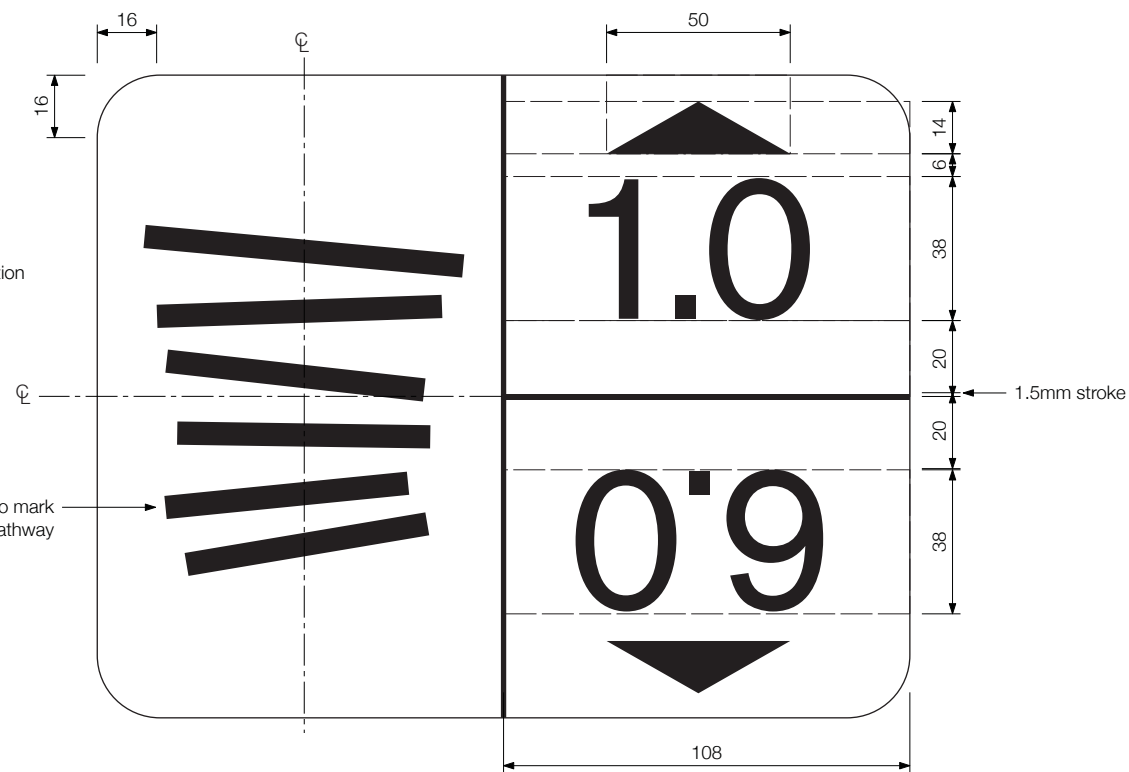
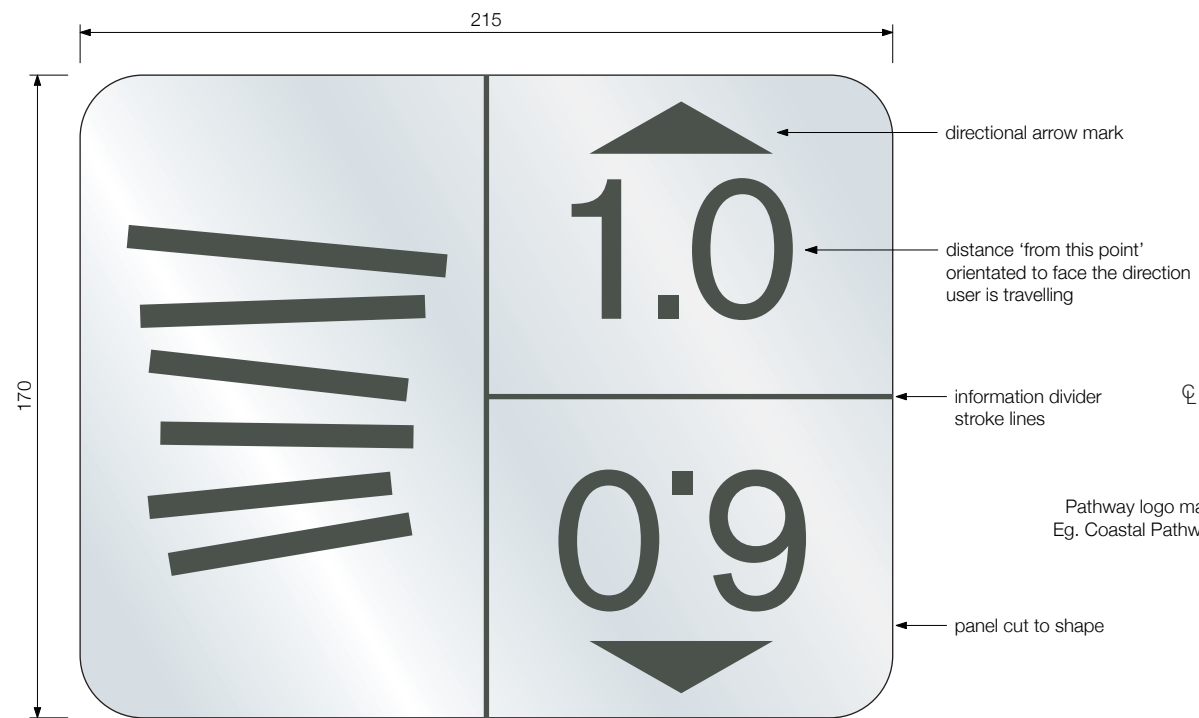

GRAPHIC LAYOUT DETAIL

GENERAL CONSTRUCTION NOTES

- Drawings show design intent. Any changes to specification which affects design intent must be approved by the SCRC Project Representative.
- Signmaker to confirm all details for approval on shop drawings prior to manufacture.

Construction Details

DISTANCE MARKER INCL. PATHWAY BRAND
 1. Minimum 2mm thick cast or deep etched metal panel cut to profile with pencil radius to edges - material to be aluminium, bronze or stainless steel. Selection of material based on context of location.

2. Surface must have texture to be slip resistant. Texture to be achieved during manufacture process. Consult and coordinate with manufacturer.

3. Graphics on panel to match Dulux Woodland Grey.

4. Surface mounted with pin and silicone to pathway.

Graphic Details

FONT
 All text = Berthold Akzidenz Grotesk Regular
COLOUR
 Graphics = To match Dulux Woodland Grey

Note

Refer to Sheet 2 of 2 for Distance Only details

Typical Graphic Layout

Scale 1:2

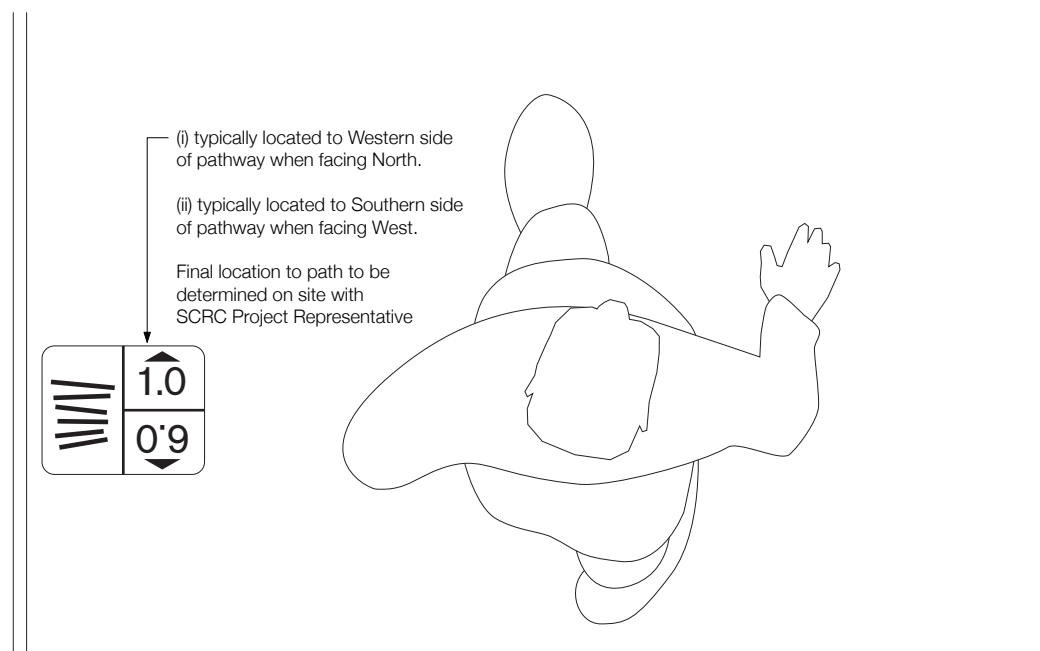

TOP VIEW - Direction North or West



TOP VIEW - Direction South or East

Typical Location Detail

Scale 1:10

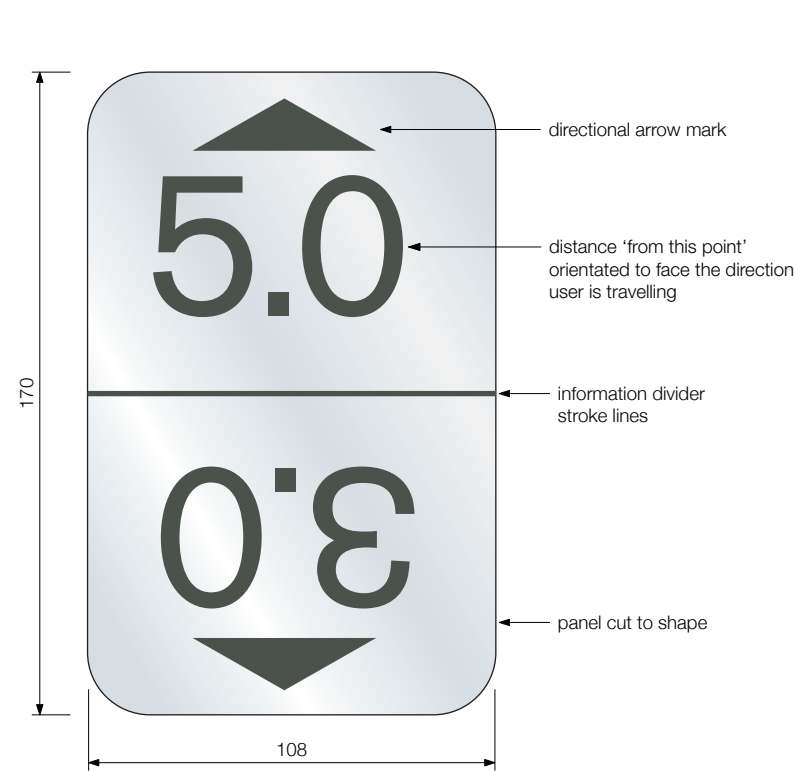

Typical Graphic Layout

Scale 1:2

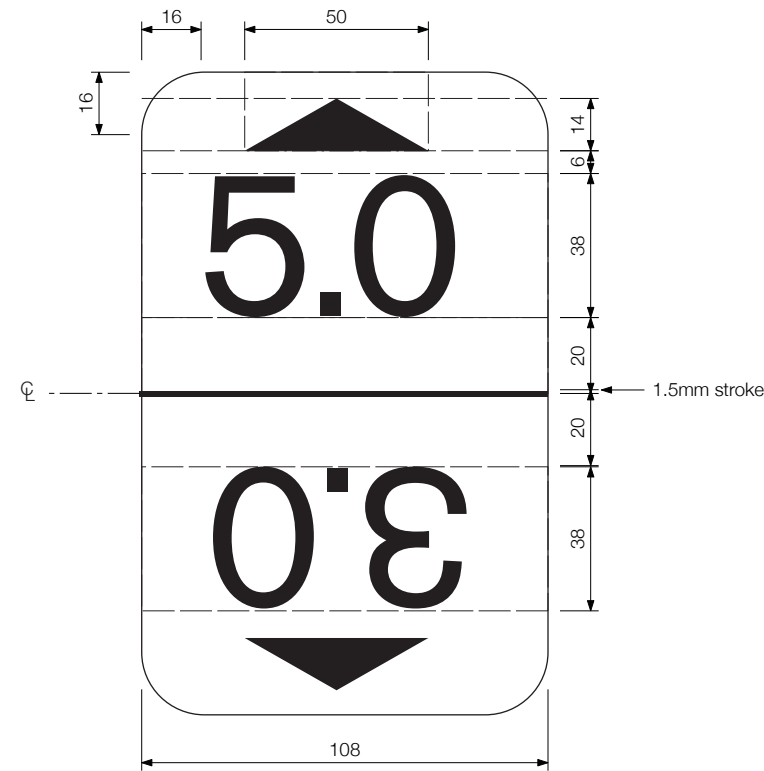

GRAPHIC LAYOUT DETAIL

GENERAL CONSTRUCTION NOTES

- Drawings show design intent. Any changes to specification which affects design intent must be approved by the SCRC Project Representative.
- Signmaker to confirm all details for approval on shop drawings prior to manufacture.

Construction Details

DISTANCE MARKER ONLY

1. Minimum 2mm thick cast or deep etched metal panel cut to profile with pencil radius to edges - material to be aluminium, bronze or stainless steel. Selection of material based on context of location.
2. Surface must have texture to be slip resistant. Texture to be achieved during manufacture process. Consult and coordinate with manufacturer.
3. Graphics on panel to match Dulux Woodland Grey.
4. Surface mounted with pin and silicone to pathway.

Graphic Details

FONT

All text = Berthold Akzidenz Grotesk Regular

COLOUR

Graphics = To match Dulux Woodland Grey

Note

Refer to Sheet 1 of 2 for Distance including Pathway Branding/Logo details

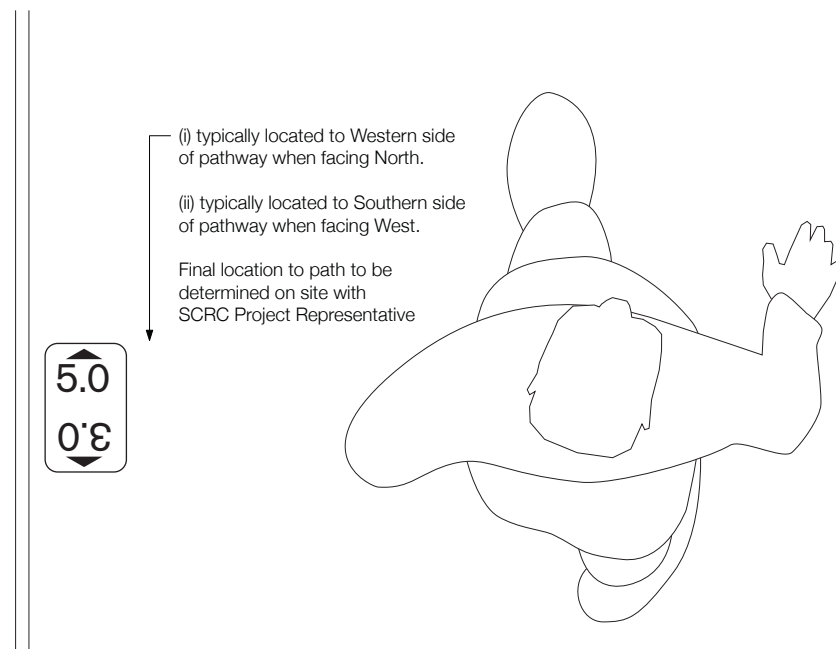

TOP VIEW - Direction North or West



TOP VIEW - Direction South or East

Typical Location Detail

Scale 1:10

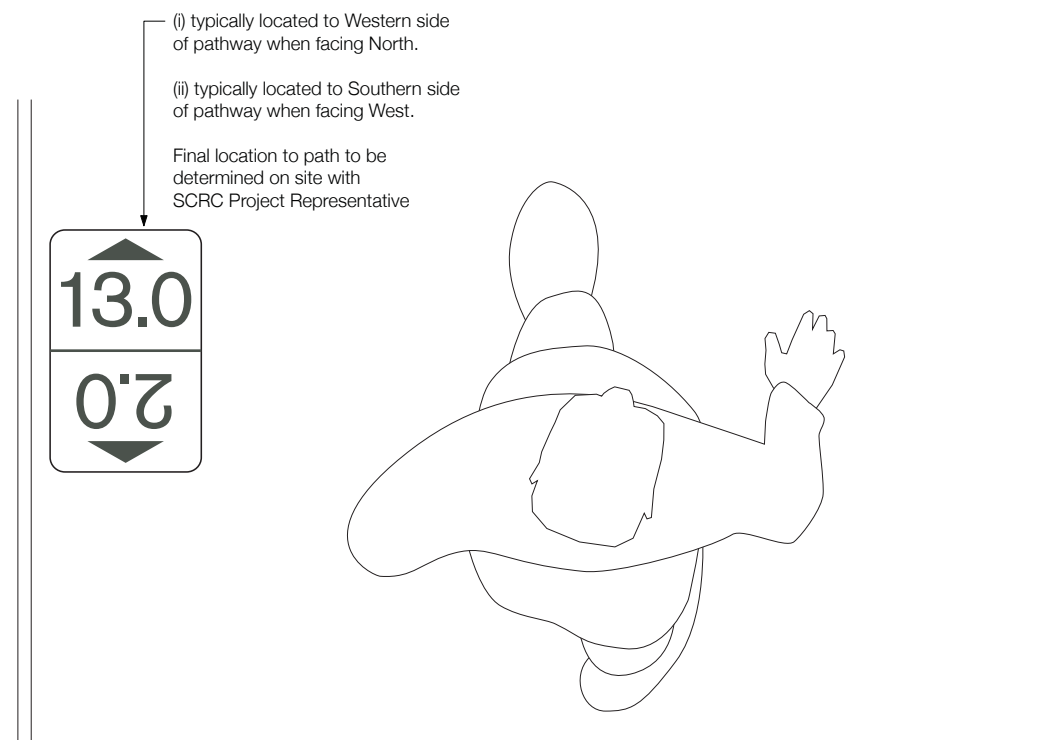
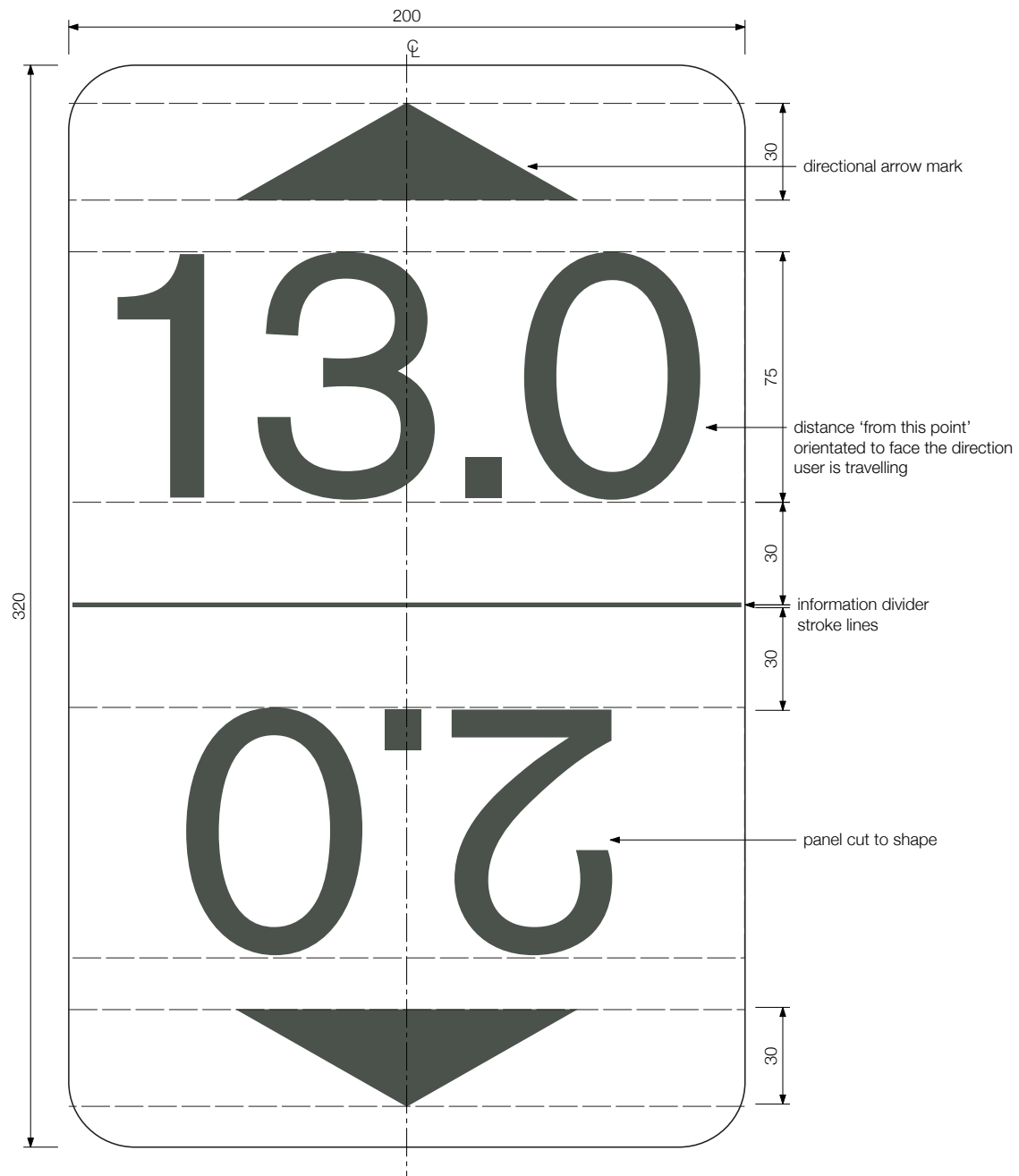

TOP VIEW - Direction North or West

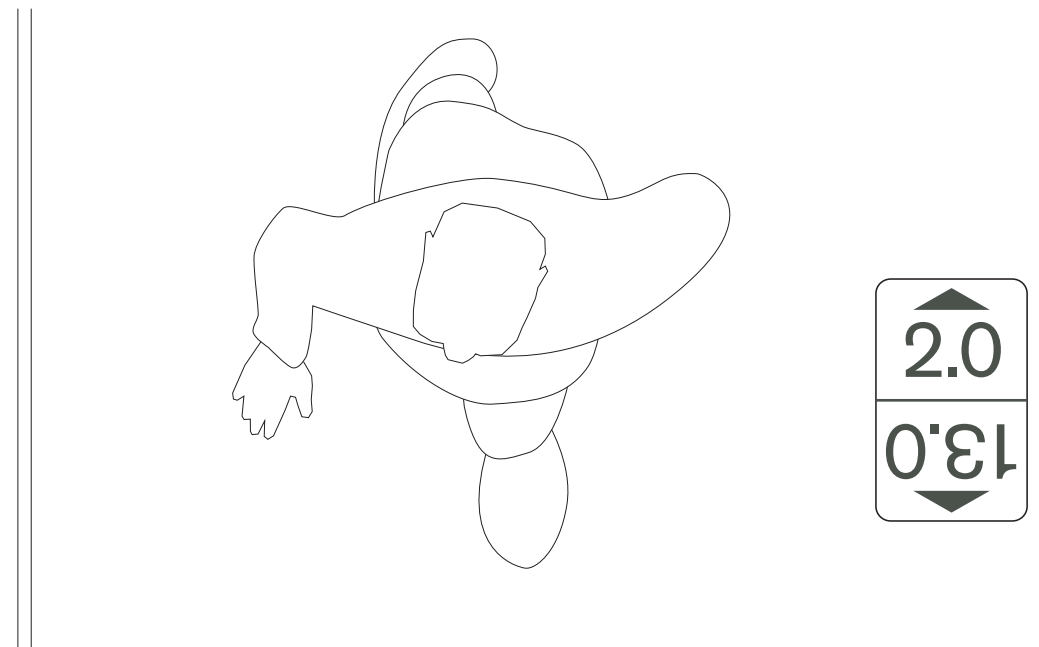

TOP VIEW - Direction South or East

Typical Location Detail
 Scale 1:10

GENERAL CONSTRUCTION NOTES

- Drawings show design intent. Any changes to specification which affects design intent must be approved by the SCRC Project Representative.
- Signmaker to confirm all details for approval on shop drawings prior to manufacture.

Construction Details

DISTANCE MARKER ONLY

1. Cut out vinyl graphic mask and roller applied paint applied to pathway, anti-slip coatings. Ensure path is cleaned and primed to ensure paint adhesion. Apply non-slip coating over marking paint as required.

Graphic Details

FONT

All text = Berthold Akzidenz Grotesk Regular

COLOUR OPTION A

Graphics = To match Dulux Woodland Grey
 Background = White

COLOUR OPTION B

Graphics = White
 Background = To match Dulux Woodland Grey

Note

Colour options provided to ensure suitable contrast from pathway surface and graphics.

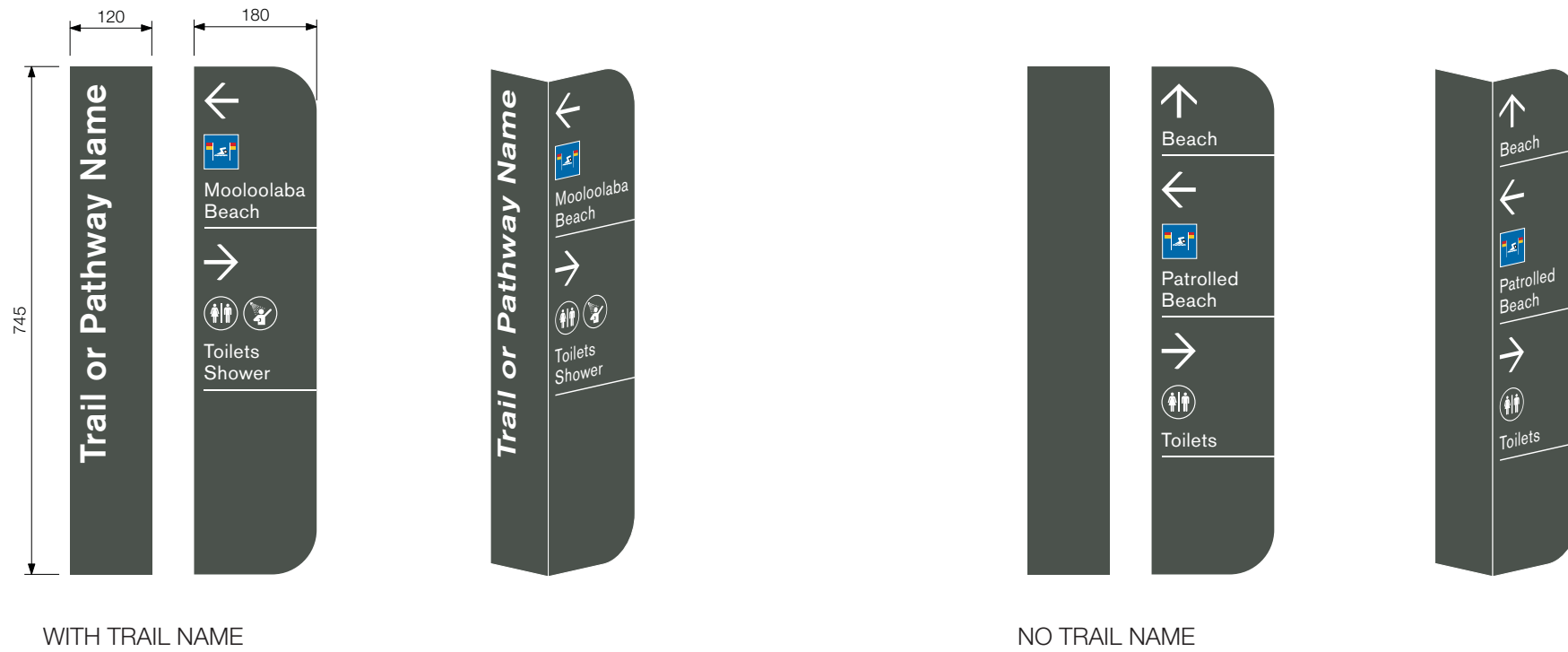

GENERAL CONSTRUCTION NOTES

- Refer to sheet 2 for Construction / Footing details
- Refer to sheet 3 for Graphic Layouts
- Drawings show design intent. Any changes to specification which affects design intent must be approved by the SCRC Project Representative.
- All structural members, fixings and/or footings to be confirmed by sign maker's engineer.
- Signmaker to confirm all details for approval on shop drawings prior to manufacture.

Typical Graphics

Scale 1:10

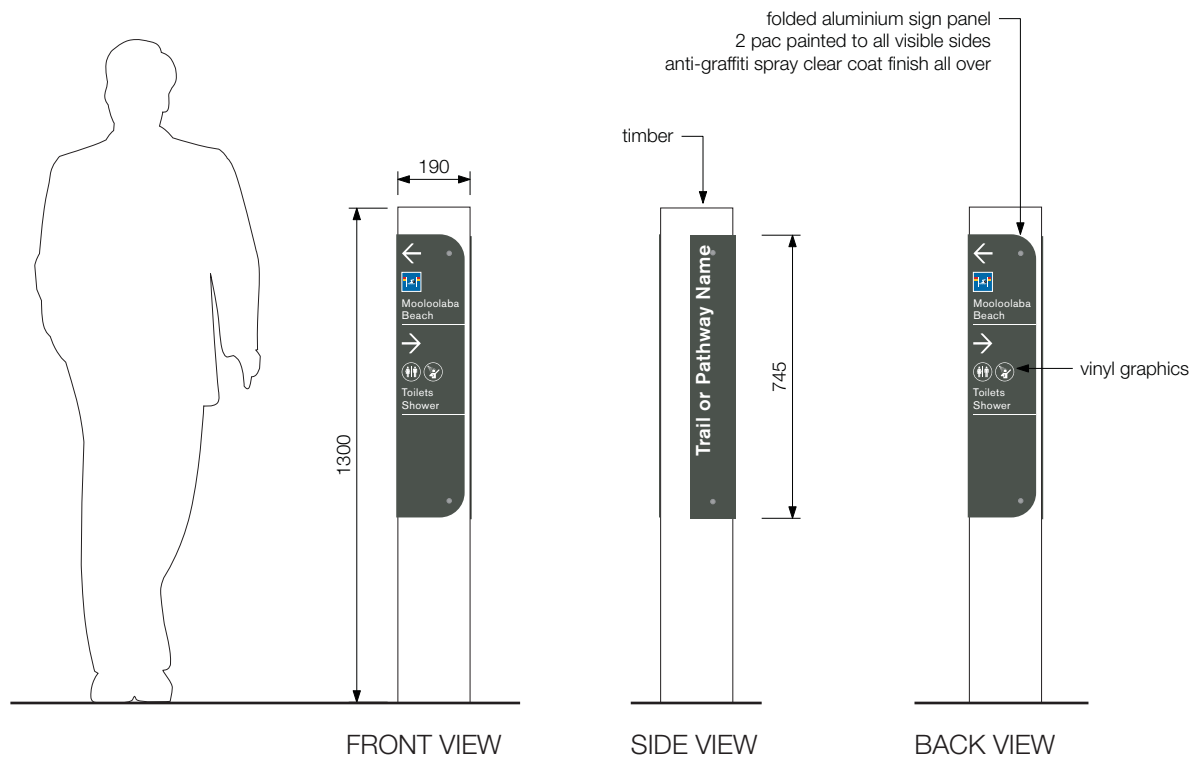

Elevations

Scale 1:20

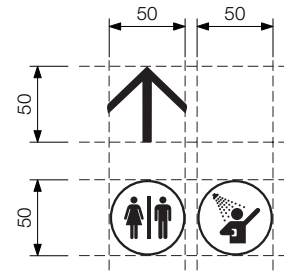

PICTOGRAMS & ARROWS

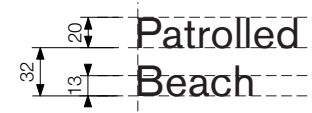

TEXT

Typical Graphic Detail

Scale 1:5

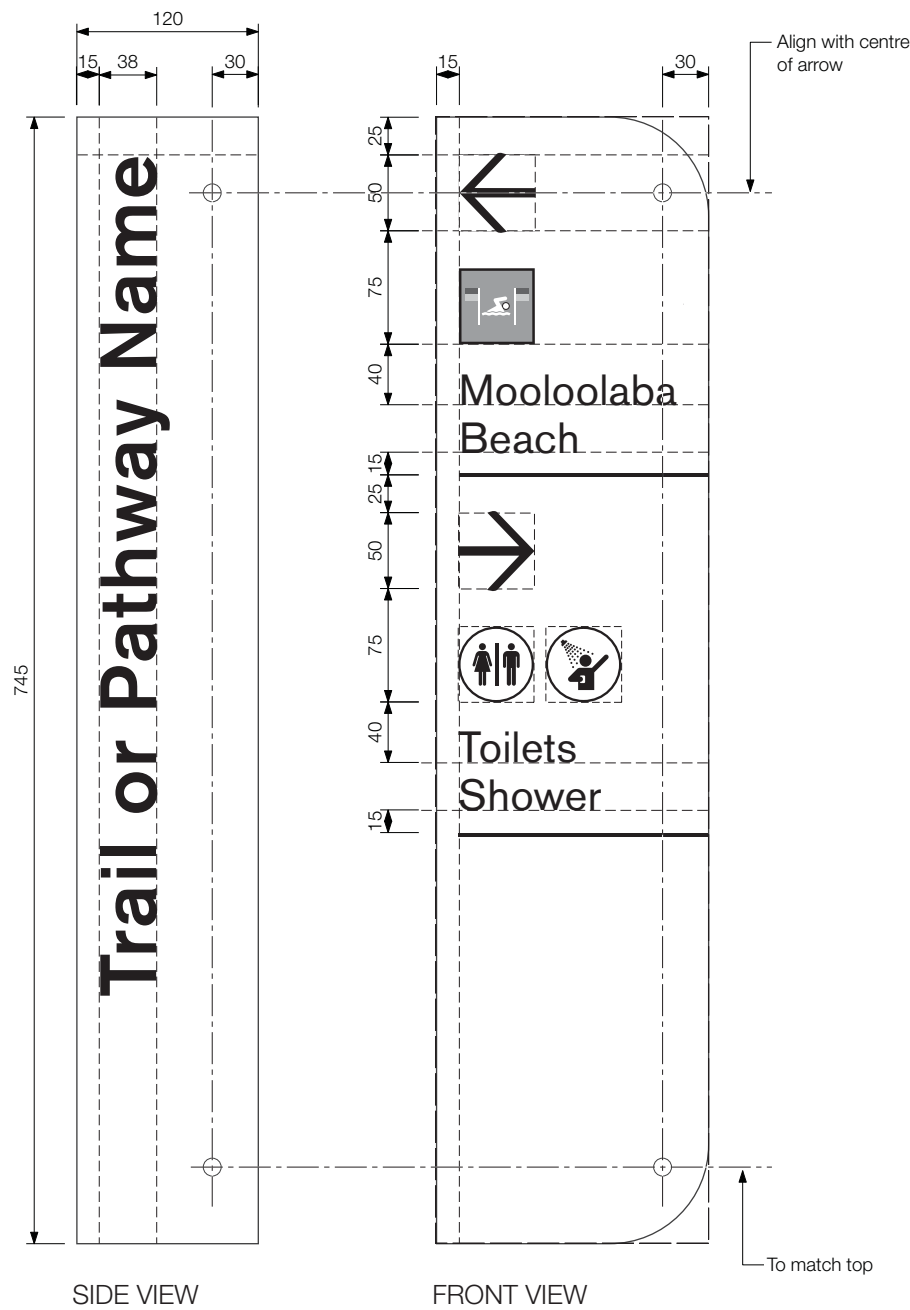

Typical Graphic Detail

Scale 1:5

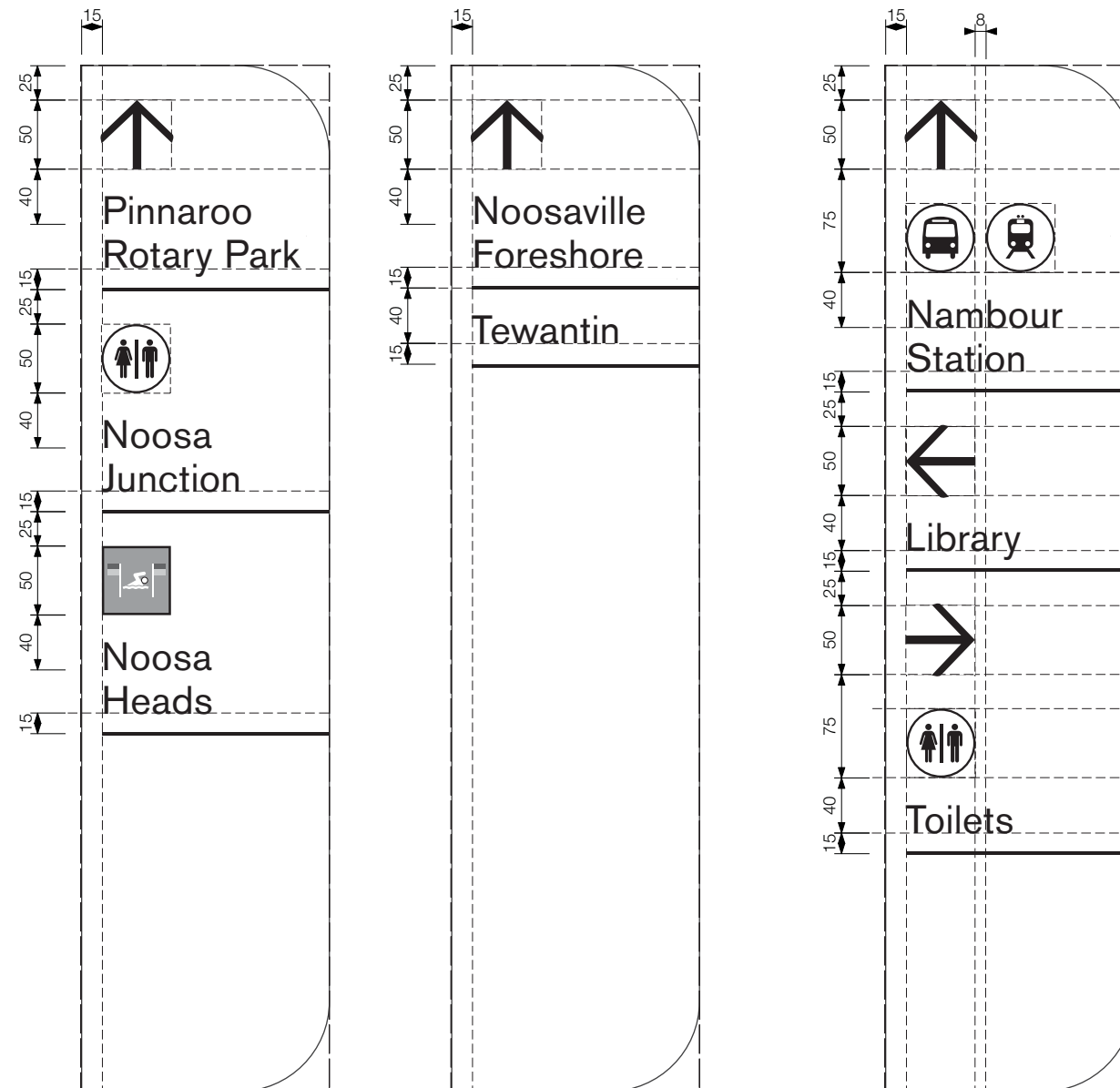

Typical Graphic Layouts

Scale 1:5

GENERAL CONSTRUCTION NOTES

- Refer to sheet 1 for General arrangement
- Refer to sheet 2 for Construction / Footing details

Graphic Details

FONT

Directional message = Akzidenz Grotesk Regular

Pathway name = Akzidenz Grotesk Medium

COLOUR

Sign panel background = Colorbond Woodland Grey

Directional message = White

Pictograms - Refer to Pictogram standards for details

Note

Panel finish = Satin finish

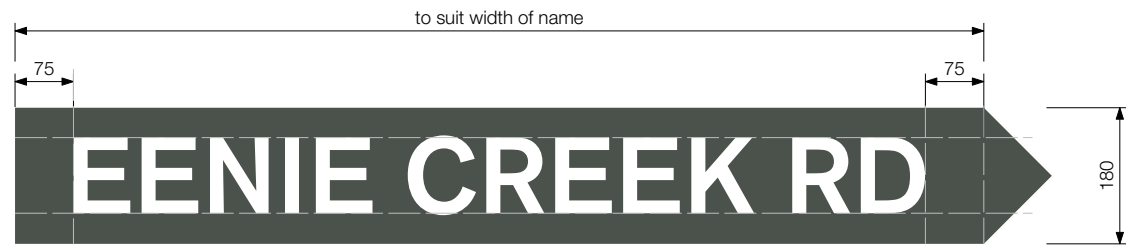

100mm cap X height

Typical Graphic Layout

Scale 1:10

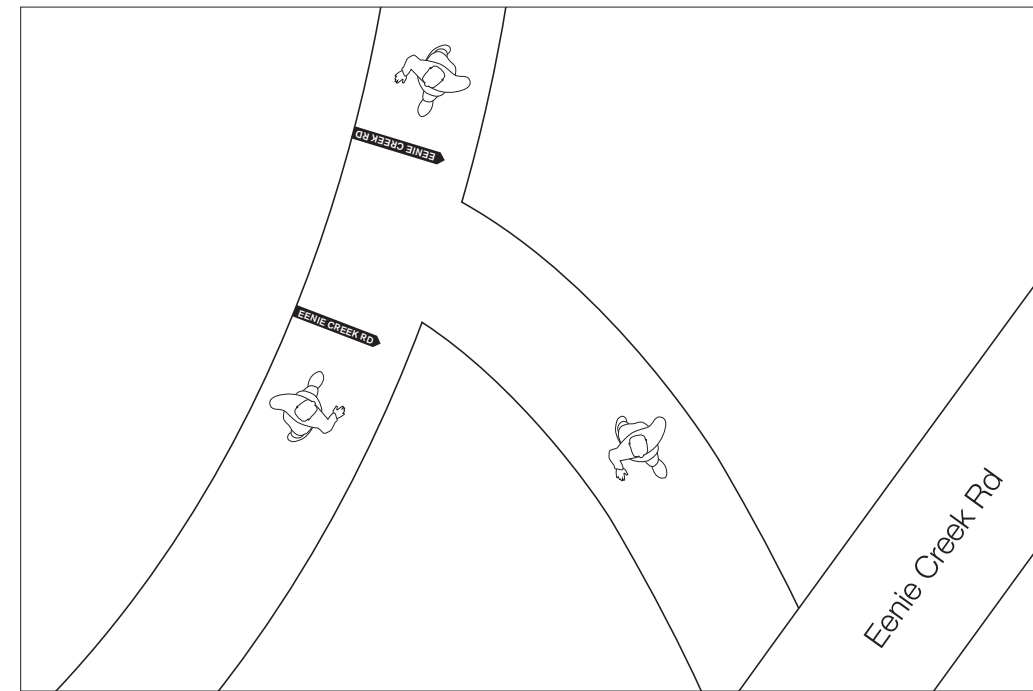

Application 1

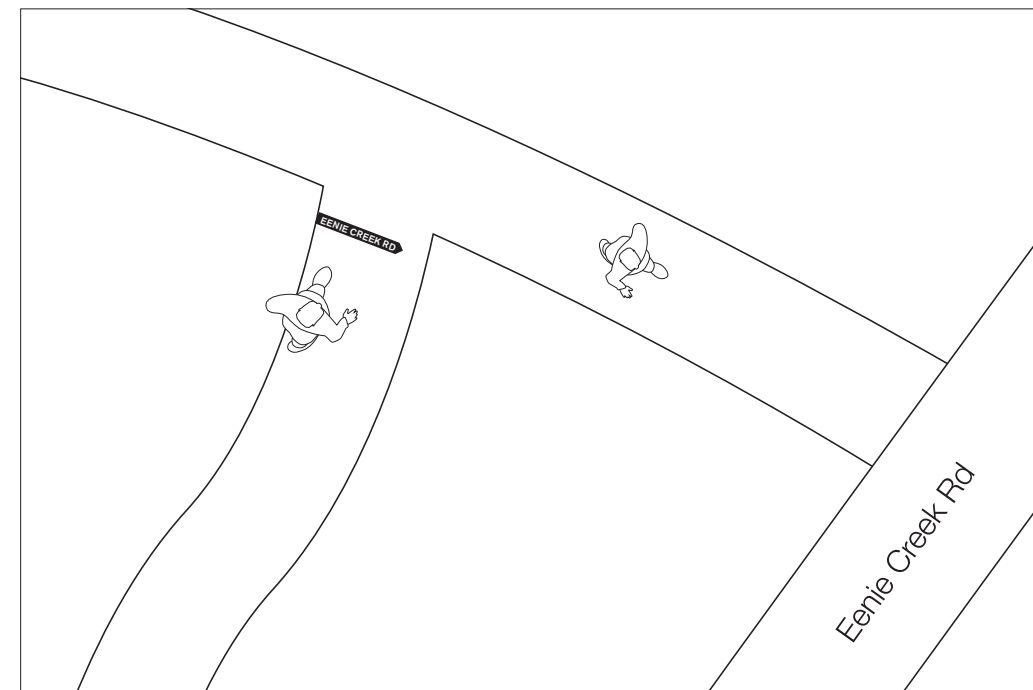

Application 2

Typical Location Details

Scale NTS

GENERAL CONSTRUCTION NOTES

- Drawings show design intent. Any changes to specification which affects design intent must be approved by the SCRC Project Representative.
- Signmaker to confirm all details for approval on shop drawings prior to manufacture.

Construction Details

Stencil graphics
 1. Cut out vinyl graphic mask and roller applied paint applied to pathway, anti-slip coatings. Ensure path is cleaned and primed to ensure paint adhesion. Apply non-slip coating over marking paint as required.

Graphic Details

FONT
 All text = Berthold Akzidenz Grotesk Medium (CAPS)
 COLOUR
 Option A = White text on Woodland Grey background
 Option B = Woodland Grey text on White Background

MOOLOOLABA ESPLANADE

Large Destination Name

EENIE CREEK RD

Medium Destination Name

ANN ST

Small Destination Name

Typical Destination Layout Details

Scale 1:20

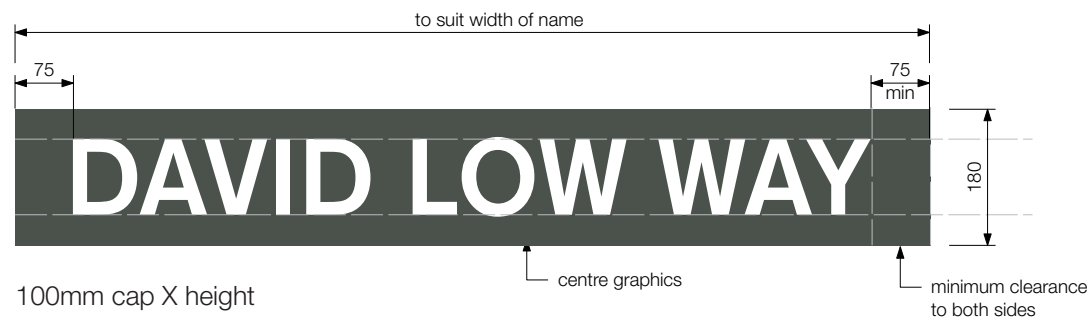

100mm cap X height

Typical Graphic Layout

Scale 1:10

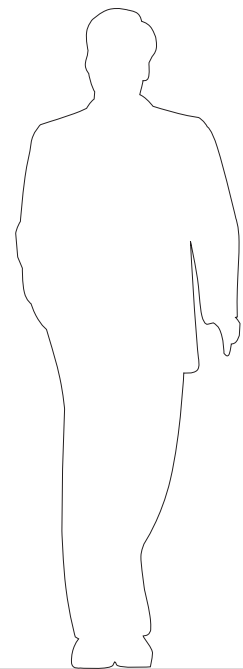

FRONT VIEW

Elevations

Scale 1:20

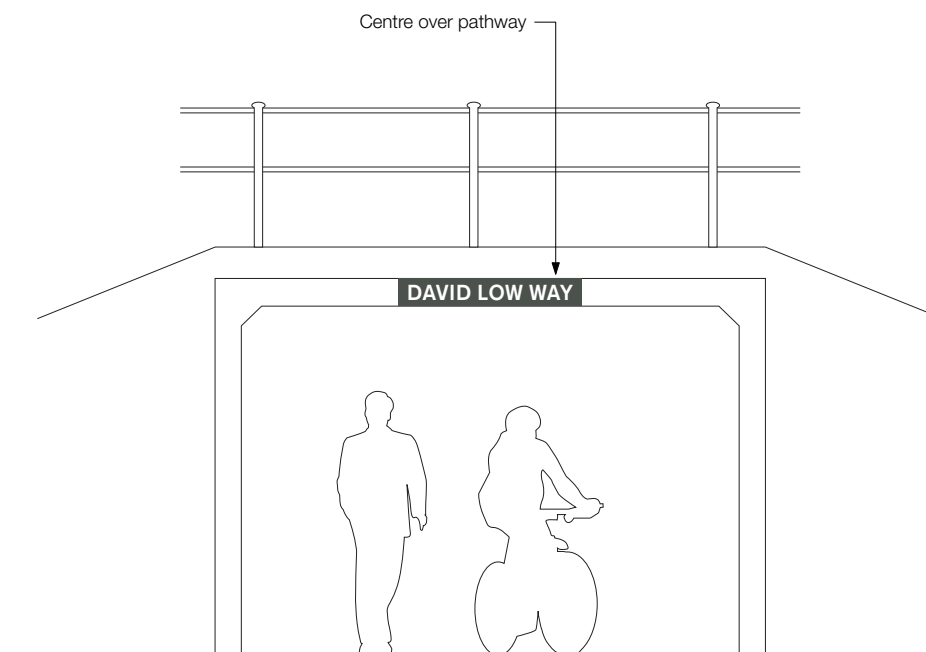

Typical Location

Scale 1:50

GENERAL CONSTRUCTION NOTES

- Drawings show design intent. Any changes to specification which affects design intent must be approved by the SCRC Project Representative.
- Signmaker to confirm all details for approval on shop drawings prior to manufacture.

Construction Details

Stencil graphics

1. Cut out vinyl graphic mask and roller applied paint applied to overpass/bridge surface. Ensure surface is cleaned and primed to ensure paint adhesion.

Sign panel

2. 2mm thick aluminium panel with applied vinyl graphics and finished with anti-graffiti clear spray coat, and security screw fixed.

Graphic Details

FONT

All text = Berthold Akzidenz Grotesk Medium (CAPS)

COLOUR

Option A = White text on Woodland Grey background

Option B = Woodland Grey text on White Background

ECONOMY SUITE 4



Economy Suite

Sign Suite Summary

Sign Type 4.1 – Economy Information Map Sign

Sign Type 4.2 – Economy Information Map Sign with Direction

Sign Type 4.3 – Economy Directional Finger Post (Post & Panels)

SUITE 4 SIGN SUMMARY

- Sign Type 4.1 – Economy Information Map Sign
- Sign Type 4.2 – Economy Information Map Sign with Direction
- Sign Type 4.3 – Economy Directional Finger Post (Post & Panels)

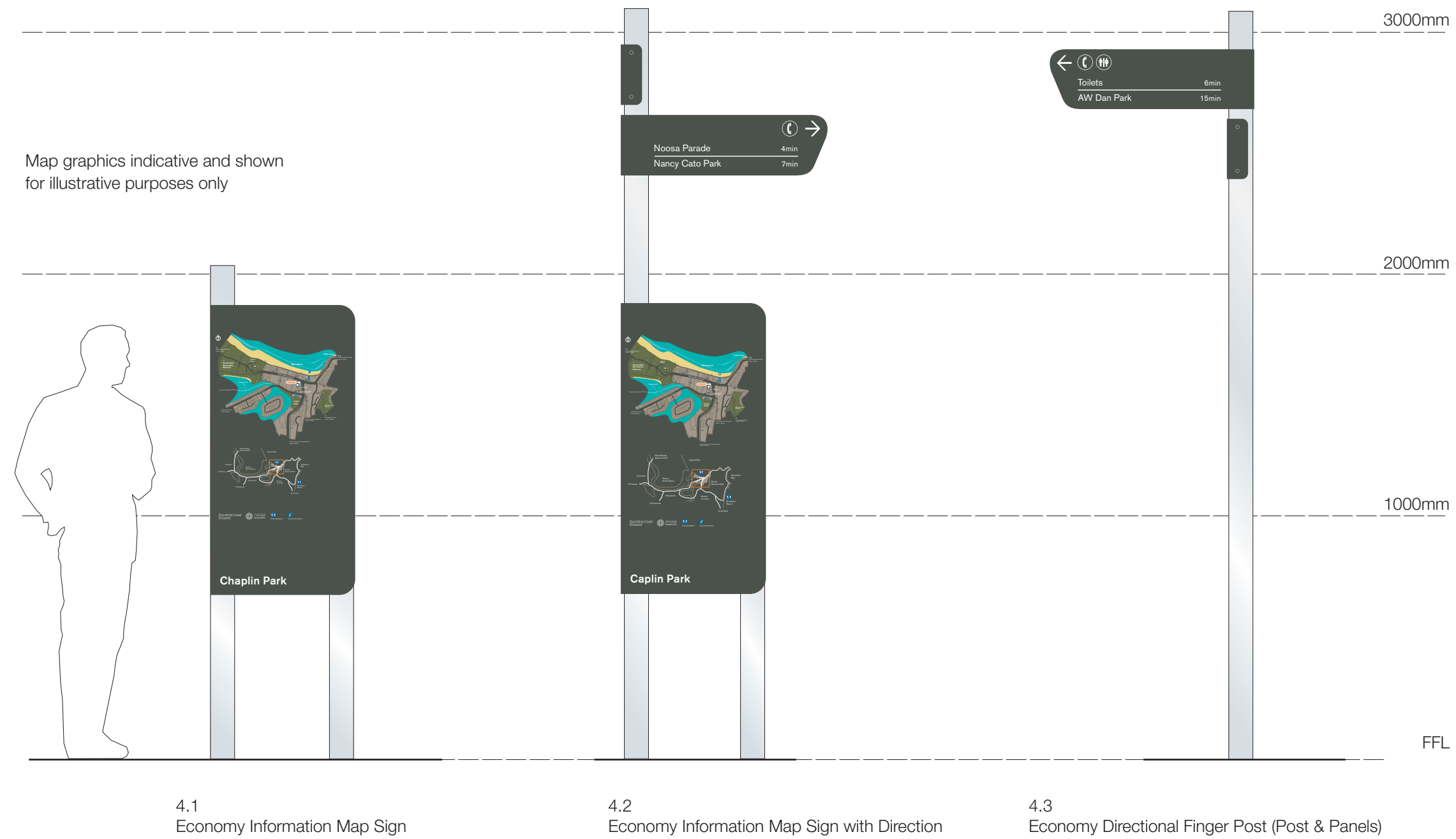

Elevations
Scale 1:20

GENERAL CONSTRUCTION NOTES

- Refer to sheet 2 for Construction details
- Refer to sheet 3 for Graphic layout details
- Refer to sheet 4 for Structural details

Map graphics indicative and shown
for illustrative purposes only

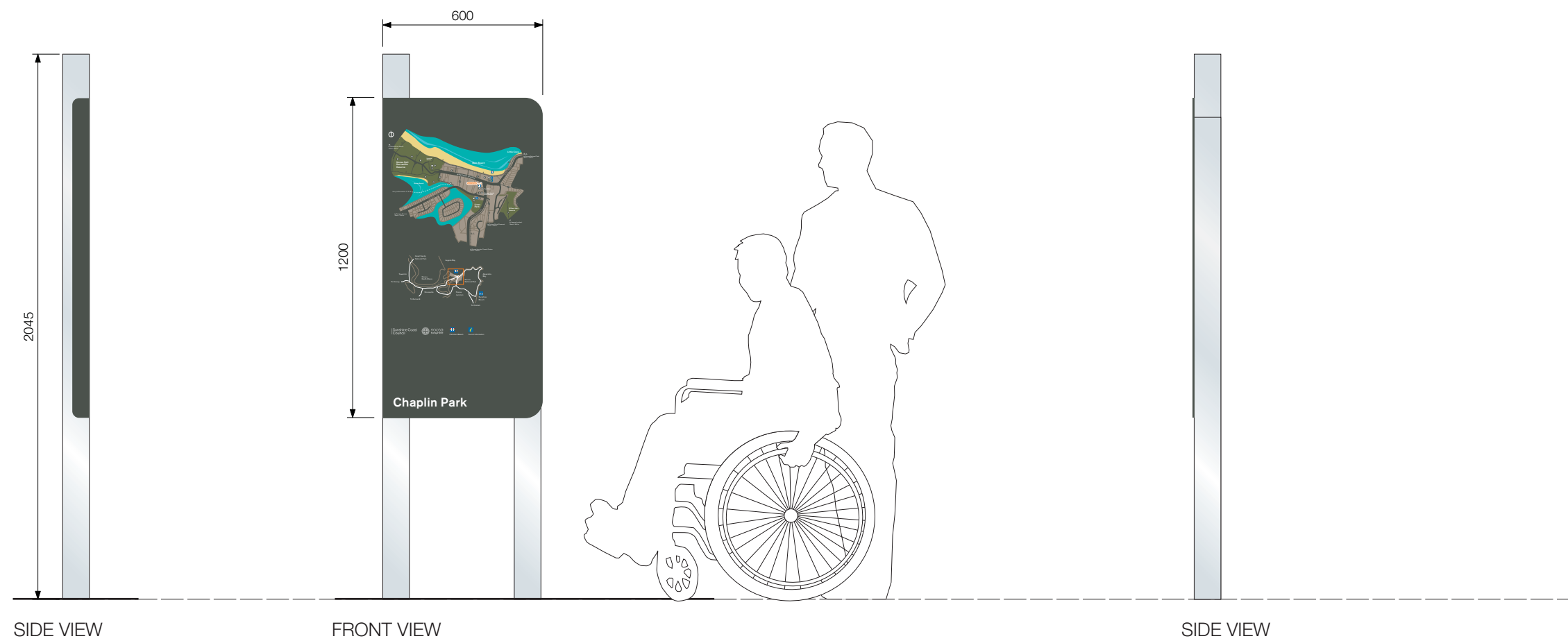

Elevations
Scale 1:20

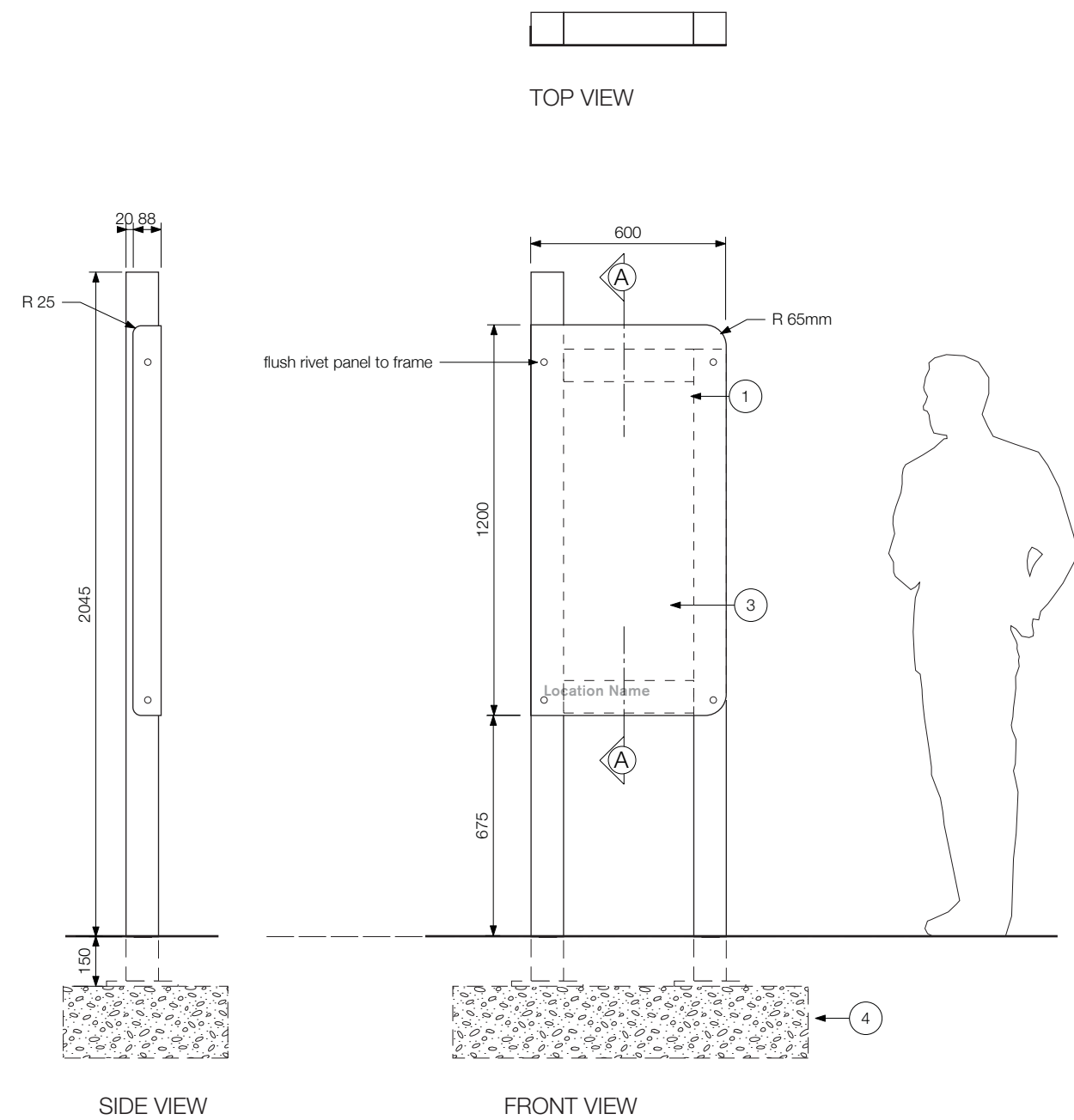

Typical Elevation
 Scale 1:20

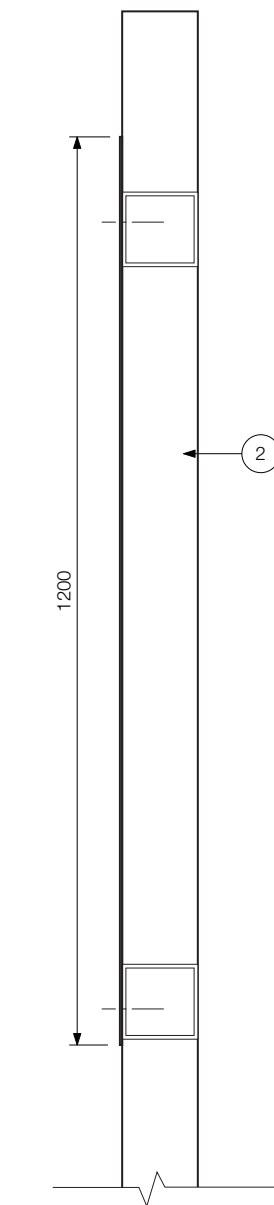

Section A
 Scale 1:10

GENERAL CONSTRUCTION NOTES

- Refer to sheet 2 for Construction details
- Refer to sheet 3 for Graphic layout details
- Refer to sheet 4 for Structural details
- Drawings show design intent. Any changes to specification which affects design intent must be approved by the SCRC Project Representative.
- All structural members, fixings and/or footings to be confirmed by sign maker's engineer.
- Signmaker to confirm all details for approval on shop drawings prior to manufacture.

Construction Details

1. 3mm thick aluminium sign panel with folded return. Flush rivet fixed to steel frame. Apply suitable clear silicone bead to back to prevent water egress.
2. 100 x 100 x 3.5mm SHS galvanised steel frame with fully welded base plate and capping.
3. Full colour, high quality digital print direct to premium 5-year polymeric external vinyl. Signmaker to provide manufacturer's warranty. To be printed on flatbed printer. Vinyl to be front applied and folded to return. Vinyl to be cut and trimmed to outer shape of sign panel edge. Nikkalite anti-graffiti overlay film NI-EF 40801-12-45 or equivalent (low gloss finish) to be applied over included folded return.
- 4a. **FOOTING OPTION 1 - BELOW GROUND**
 Reinforced concrete pad/pier footing to signmakers' engineer specification. All fixings shall be below ground level to reduce trip hazards. Re-instate / make good paving or pavement, with no changes of level greater than 3mm and no gradients steeper than 1:40.
- 4b. **FOOTING OPTION 2 - ABOVE GROUND**
 Mechanical anchors to existing concrete slab. Leveling grout as required. Suitable hold down bolts with stainless steel dome head nuts. Site inspection to confirm suitability of slab prior to installation.

Material Finish

Frame = Galvanised finish

GENERAL CONSTRUCTION NOTES

- Refer to sheet 1 for General arrangement
- Refer to sheet 2 for Construction details
- Refer to sheet 4 for Structural details

Graphic Details

FONT

Name = Berthold Akzidenz Grotesk Medium

COLOUR

Sign panel background = Dulux Woodland Grey®

Map = Full colour map. Refer Map Standards for details

Location name = White

Note

Contextual Map size to increase in comparison to the You Are Here Map if required - based on location.

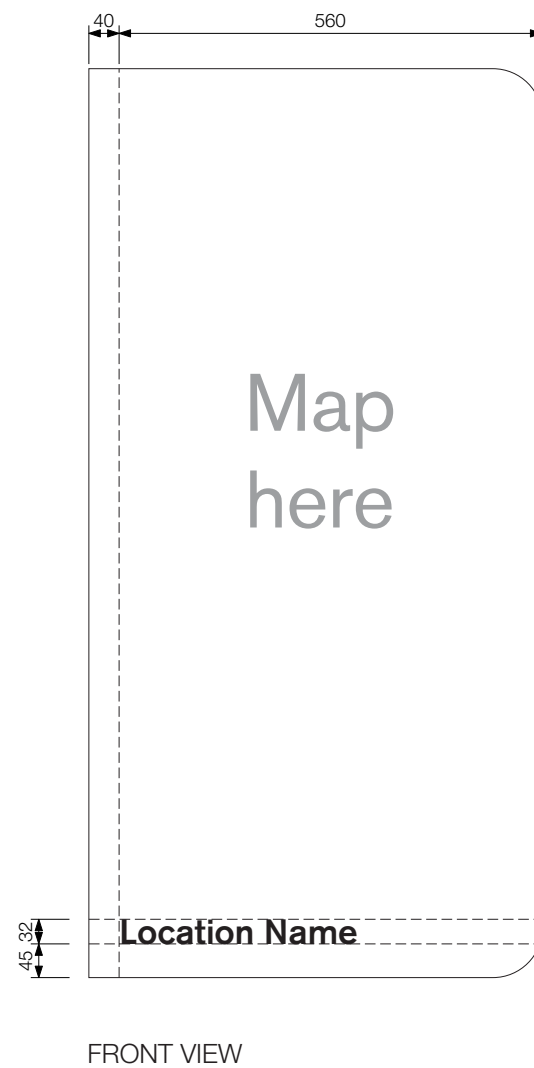
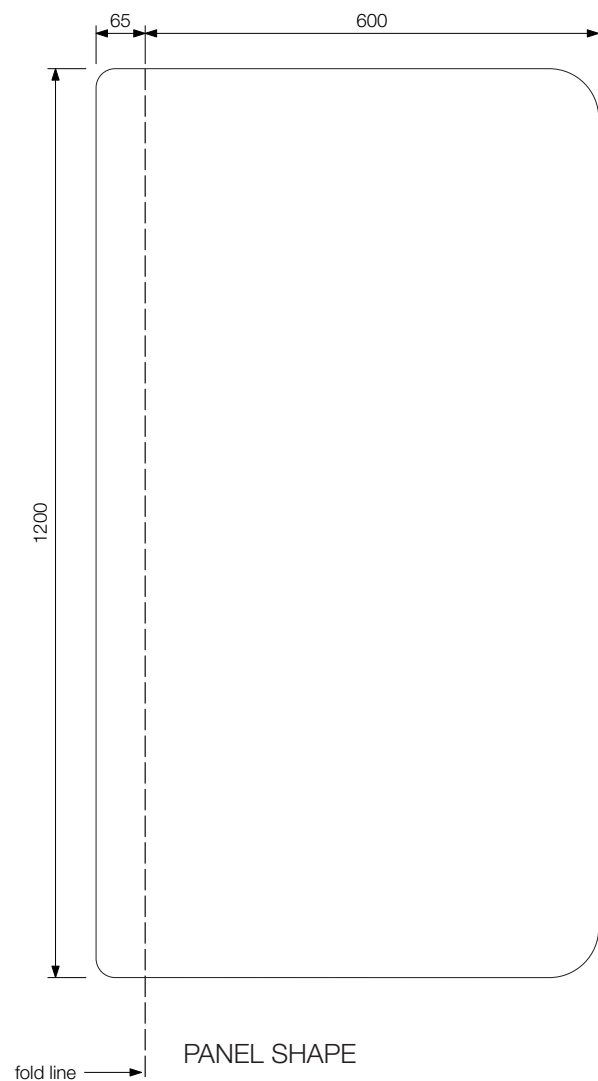

Typical Graphics

Scale 1:10

GENERAL CONSTRUCTION NOTES

- Refer to sheet 1 for General Arrangement
- Refer to sheet 2 for Construction details
- Refer to sheet 3 for Graphic details

NOTE

- Specifications shown are for preliminary advice only.
- All structural members, fixings and/or footings to be confirmed by sign maker's engineer.

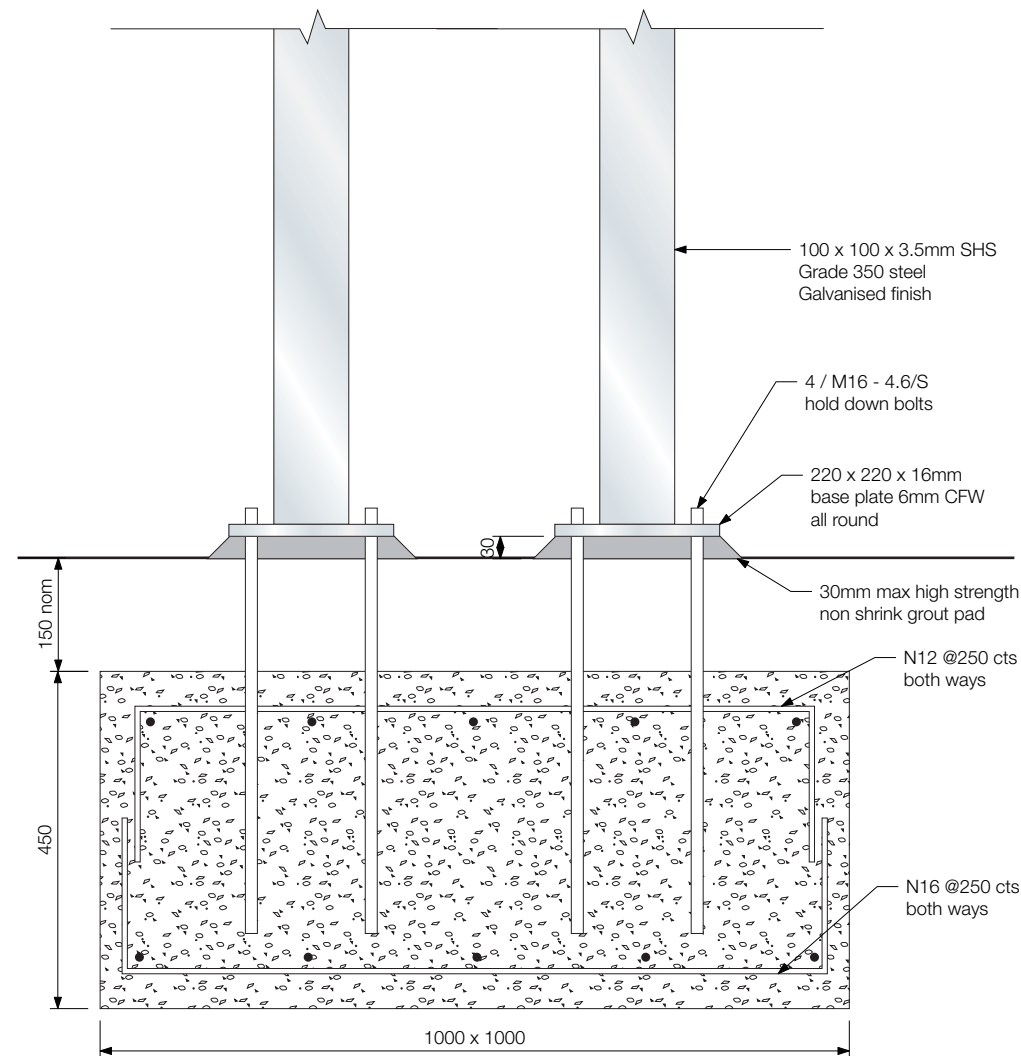

Pad footing

Above Ground Footing Detail

Scale 1:10

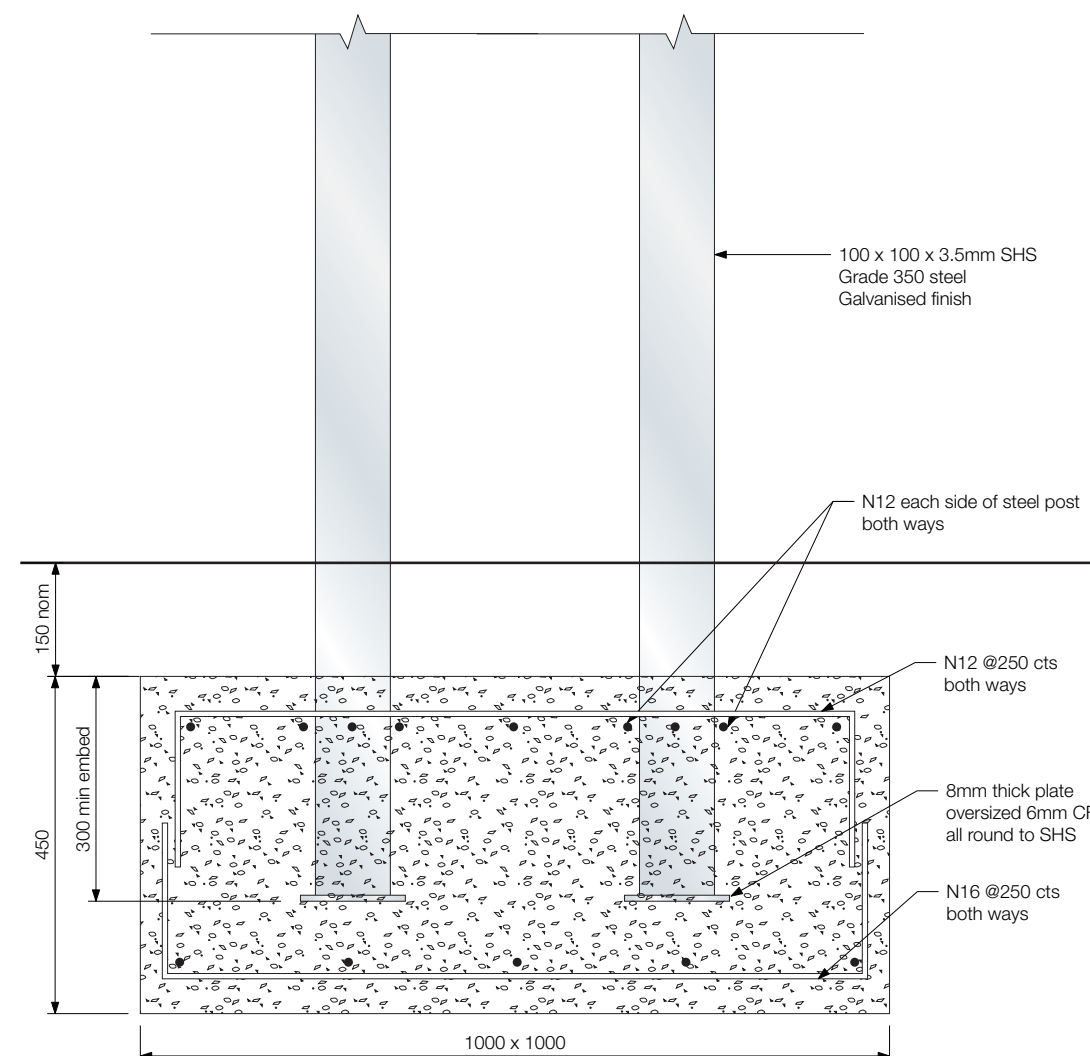

Pad footing

Direct Embed Footing Detail

Scale 1:10

- GENERAL CONSTRUCTION NOTES
- Refer to sheet 2 for Single Sided Arrangement
 - Refer to sheet 3 for Construction details
 - Refer to sheet 4 for Graphic Layout details
 - Refer to sheet 5 for Footing details
 - Refer to sheet 6 for Allocation of Fingerboards

Map graphics indicative and shown for illustrative purposes only

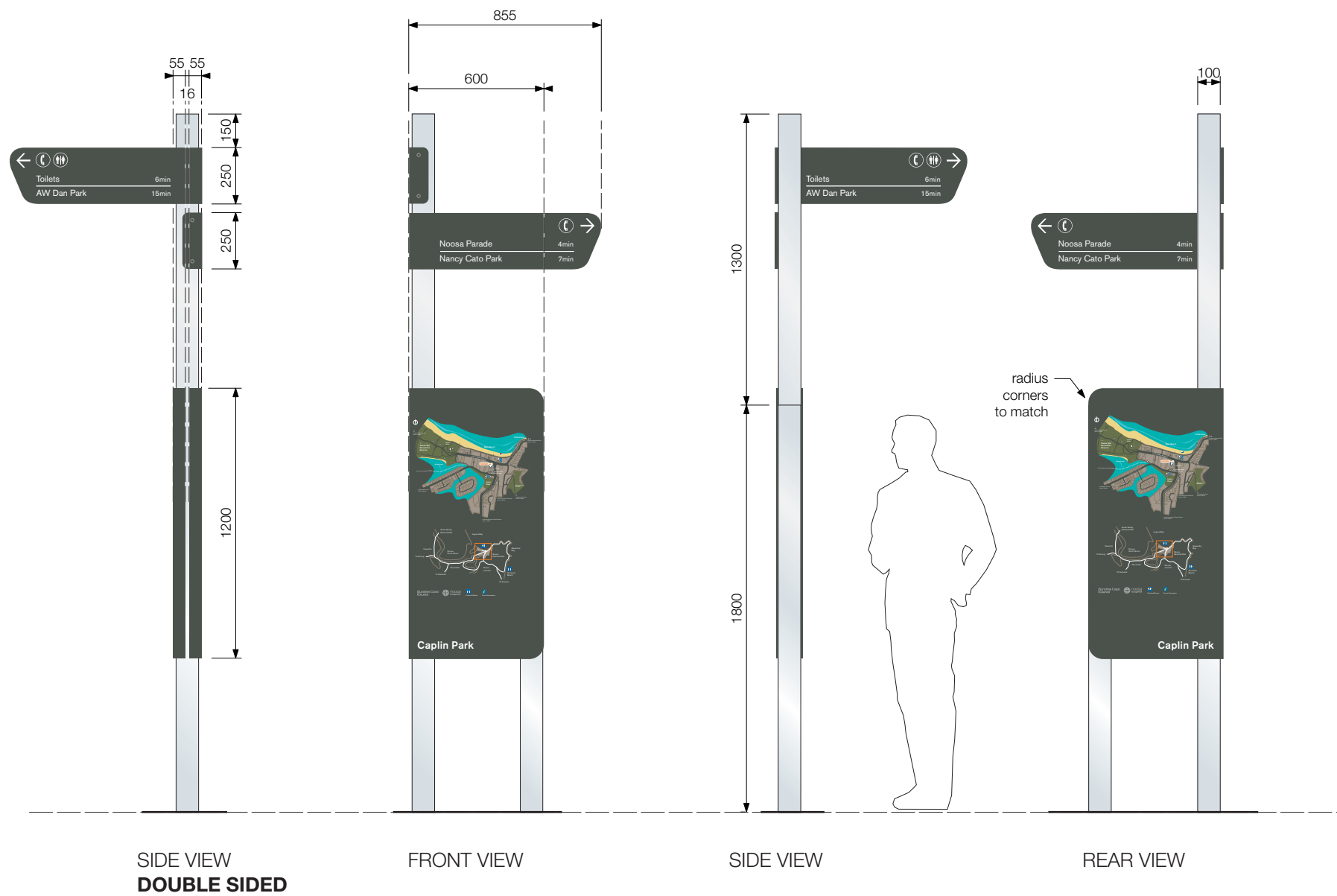

Elevations
Scale 1:25

GENERAL CONSTRUCTION NOTES

- Refer to sheet 1 for Double Sided Arrangement
- Refer to sheet 3 for Construction details
- Refer to sheet 4 for Graphic layout details
- Refer to sheet 5 for Footing details
- Refer to sheet 6 for Allocation of Fingerboards

Map graphics indicative and shown for illustrative purposes only

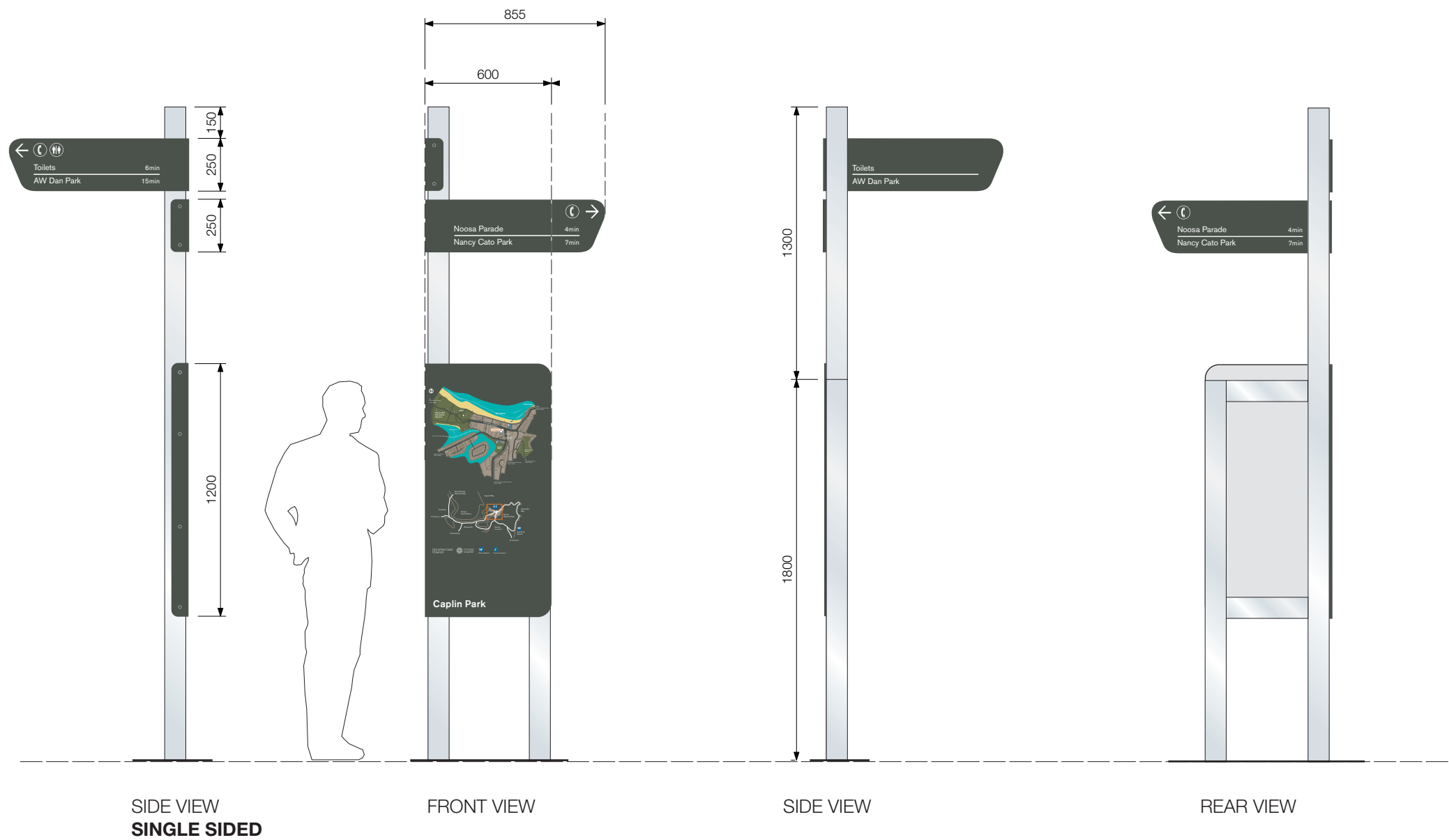

Elevations
Scale 1:25

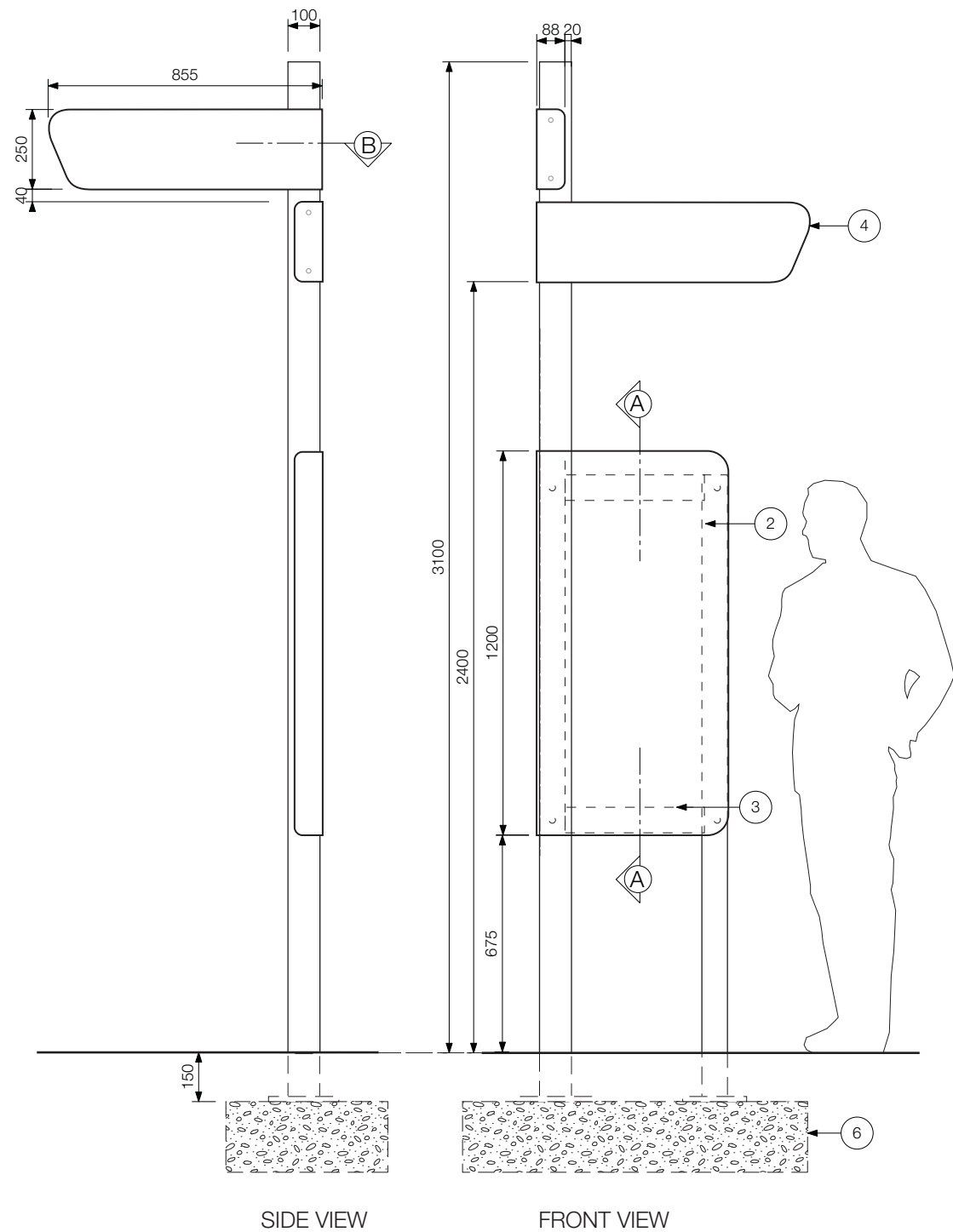

Typical Elevation - Map + Fingerboard panels
Scale 1:20

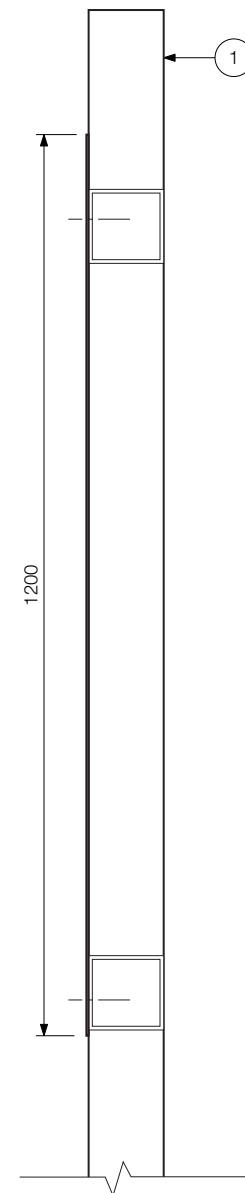

Map Panel fixing
Scale 1:10

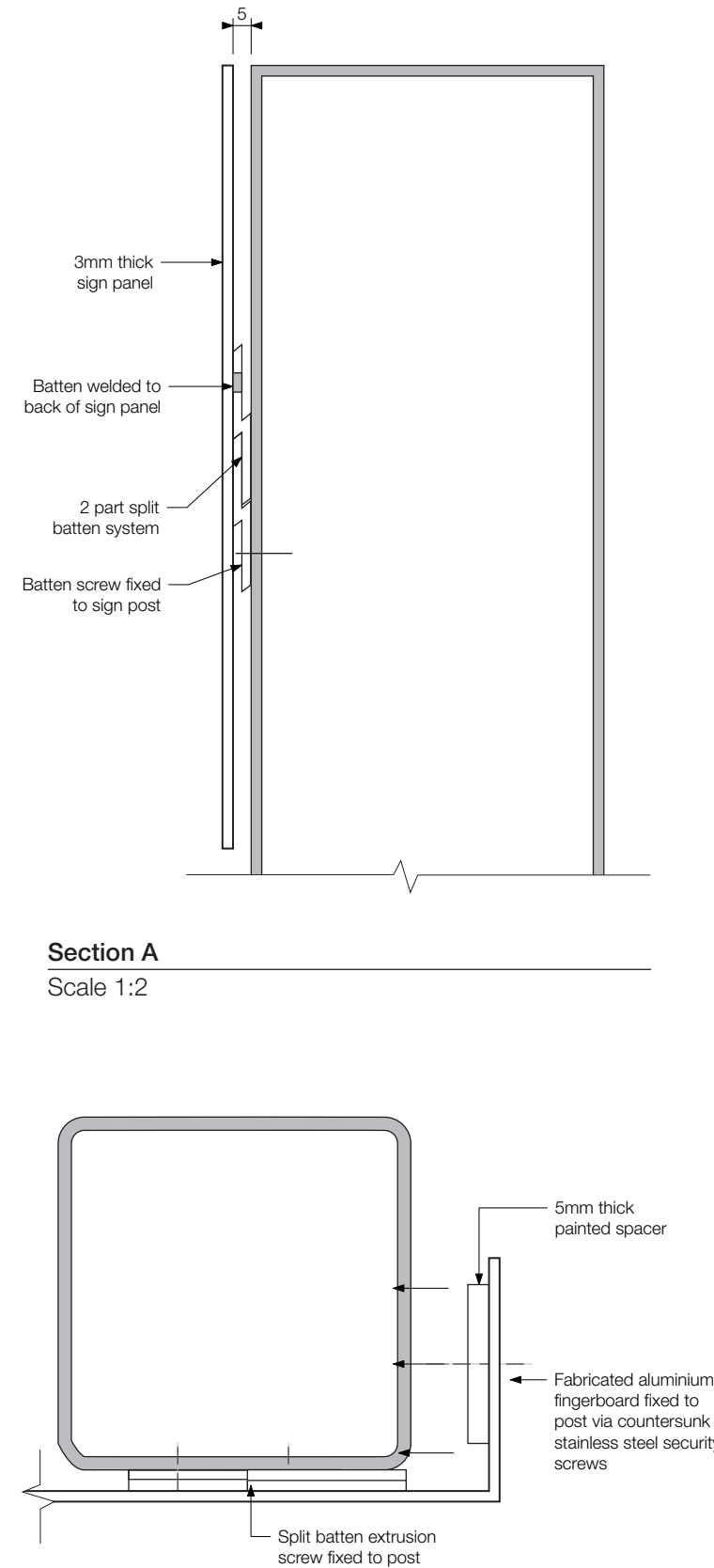

GENERAL CONSTRUCTION NOTES

- Refer to sheet 1 for Double Sided Arrangement
- Refer to sheet 2 for Single Sided Arrangement
- Refer to sheet 4 for Graphic layout details
- Refer to sheet 5 for Footing details
- Refer to sheet 6 for Allocation of Fingerboards
- Drawings show design intent. Any changes to specification which affects design intent must be approved by the SCRC Project Representative.
- All structural members, fixings and/or footings to be confirmed by sign maker's engineer.
- Signmaker to confirm all details for approval on shop drawings prior to manufacture.

Construction Details

1. 100 x 100 x 3.5mm SHS grade 350 post with fully welded base plate and 6mm thick capping. 6mm CFW 220 x 220 x 16mm thick base plate. Galvanised finish. Drill and tap frame to frame for fingerboard panel fixing.
2. 3mm thick aluminium sign panel with folded return. Flush rivet fixed to steel frame. Apply suitable clear silicone bead to back to prevent water egress.
3. Map sign panel details - refer Graphic Layout sheet.
4. Fingerboard panel
3mm thick fabricated aluminium sign panel with folded return. Post hexagon socket countersunk head machine stainless steel screws to fix to frame. For graphic details, Refer Graphic Layout sheet.

6a. FOOTING OPTION 1 - BELOW GROUND

Footing to be 150mm nominal to coordinate with paving. Reinforced concrete pad/pier footing to signmakers' engineer specification. All fixings shall be below ground level to reduce trip hazards. Re-instate / make good paving or pavement, with no changes of level greater than 3mm and no gradients steeper than 1:40.

6b. FOOTING OPTION 2 - ABOVE GROUND

Mechanical anchors to existing concrete slab. Leveling grout as required. Fixing via M12 hold down bolts with stainless steel dome head nuts. Site inspection to confirm suitability of slab prior to installation.

Material Finish

Frame = Galvanised finish

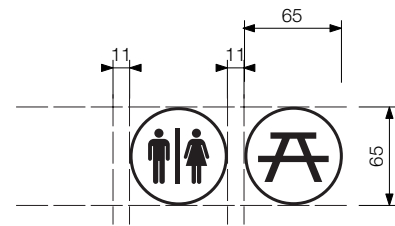

Toilets 6min

Alec Loveday Park 8min

Typical Graphic Layout

Scale 1:5

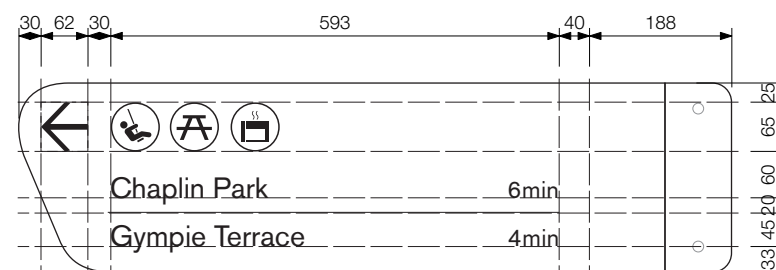
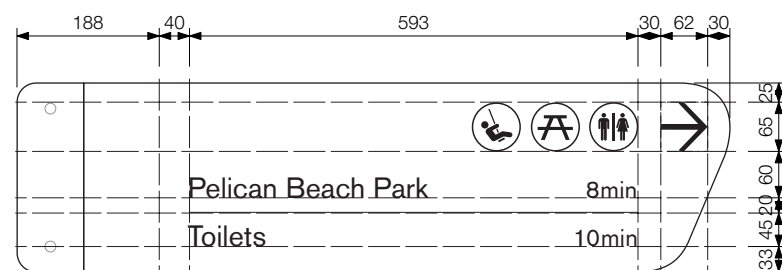
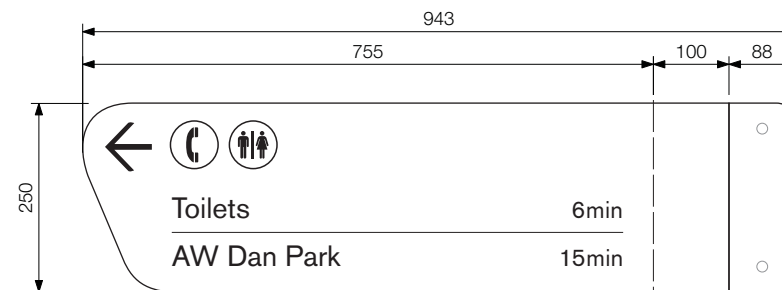
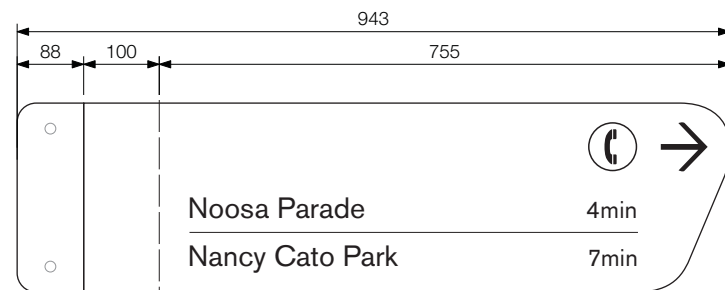

RIGHT DIRECTION

LEFT DIRECTION

Typical Graphic Layouts

Scale 1:10

GENERAL CONSTRUCTION NOTES

- Refer to sheet 1 for Double Sided Arrangement
- Refer to sheet 2 for Single Sided Arrangement
- Refer to sheet 3 for Construction details
- Refer to sheet 5 for Footing details
- Refer to sheet 6 for Allocation of Fingerboards

Graphic Details

FONT

Directional text = Berthold Akzidenz Grotesk Regular
 Name = Berthold Akzidenz Grotesk Medium

COLOUR

Sign panel background = Colorbond Woodland Grey
 Directional message = White

Pictograms - Refer to Pictogram standards for details

MAP DETAILS

Full colour, high quality digital print direct to premium 5-year polymeric external vinyl. Signmaker to provide manufacturer's warranty. To be printed on flatbed printer.

Vinyl to be front applied to both sides and folded to return. Vinyl to be cut and trimmed to outer shape of sign panel edge.

Nikkalite anti-graffiti overlay film NI-EF 40801-12-45 or equivalent (low gloss finish) to be applied over included folded return.

FINGER PANELS

Full colour, high quality digital print direct to premium 5-year polymeric external vinyl. Signmaker to provide manufacturer's warranty. To be printed on flatbed printer.

Vinyl to be front applied and folded to return. Vinyl to be cut and trimmed to outer shape of sign panel edge.

Nikkalite anti-graffiti overlay film NI-EF 40801-12-45 or equivalent (low gloss finish) to be applied over included folded return.

Note

Contextual Map size to increase in comparison to the You Are Here Map if required - based on location.

GENERAL CONSTRUCTION NOTES

- Refer to sheet 1 for Double Sided Arrangement
- Refer to sheet 2 for Single Sided Arrangement
- Refer to sheet 3 for Construction details
- Refer to sheet 4 for Graphic layout details
- Refer to sheet 6 for Allocation of Fingerboards

NOTE

- Specifications shown are for preliminary advice only.
- All structural members, fixings and/or footings to be confirmed by sign maker's engineer.

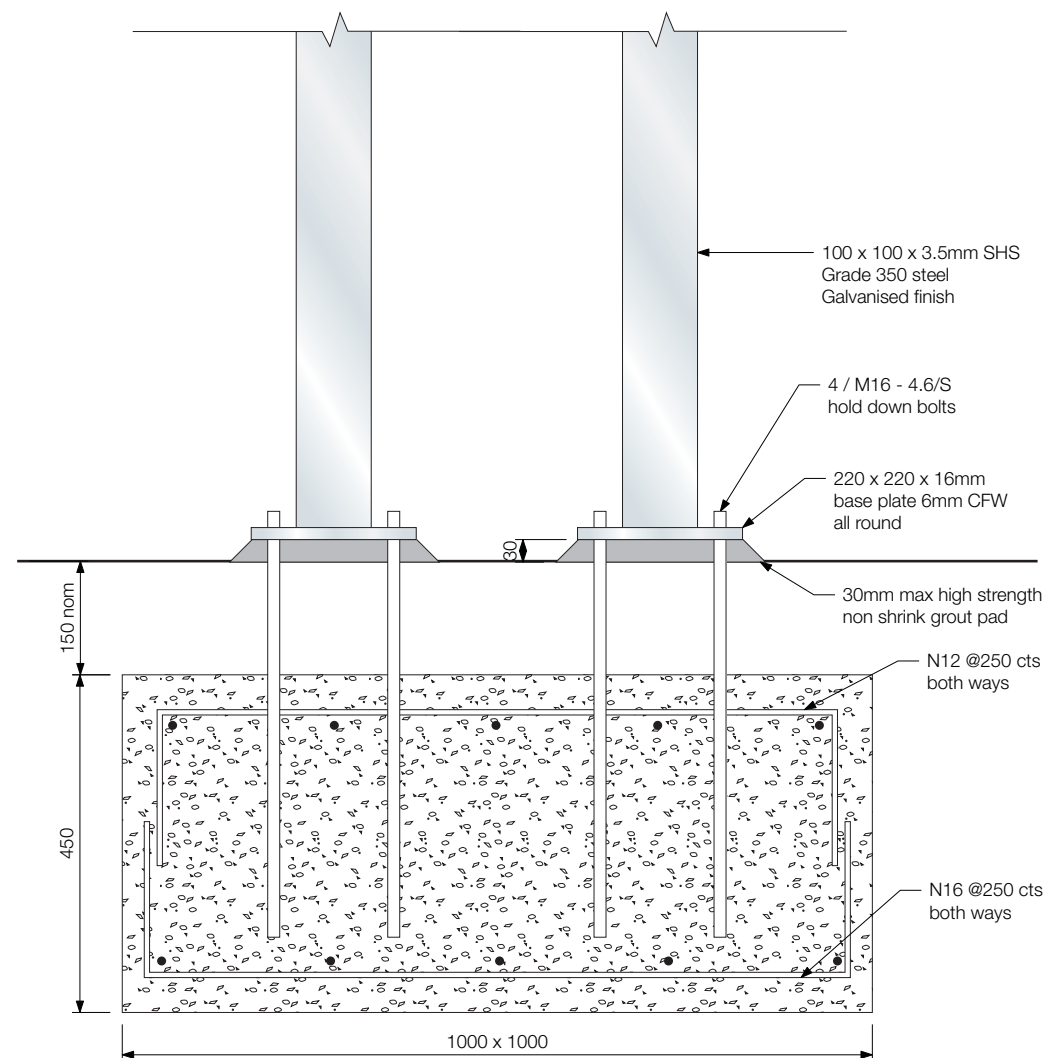

Above Ground Footing Detail

Scale 1:10

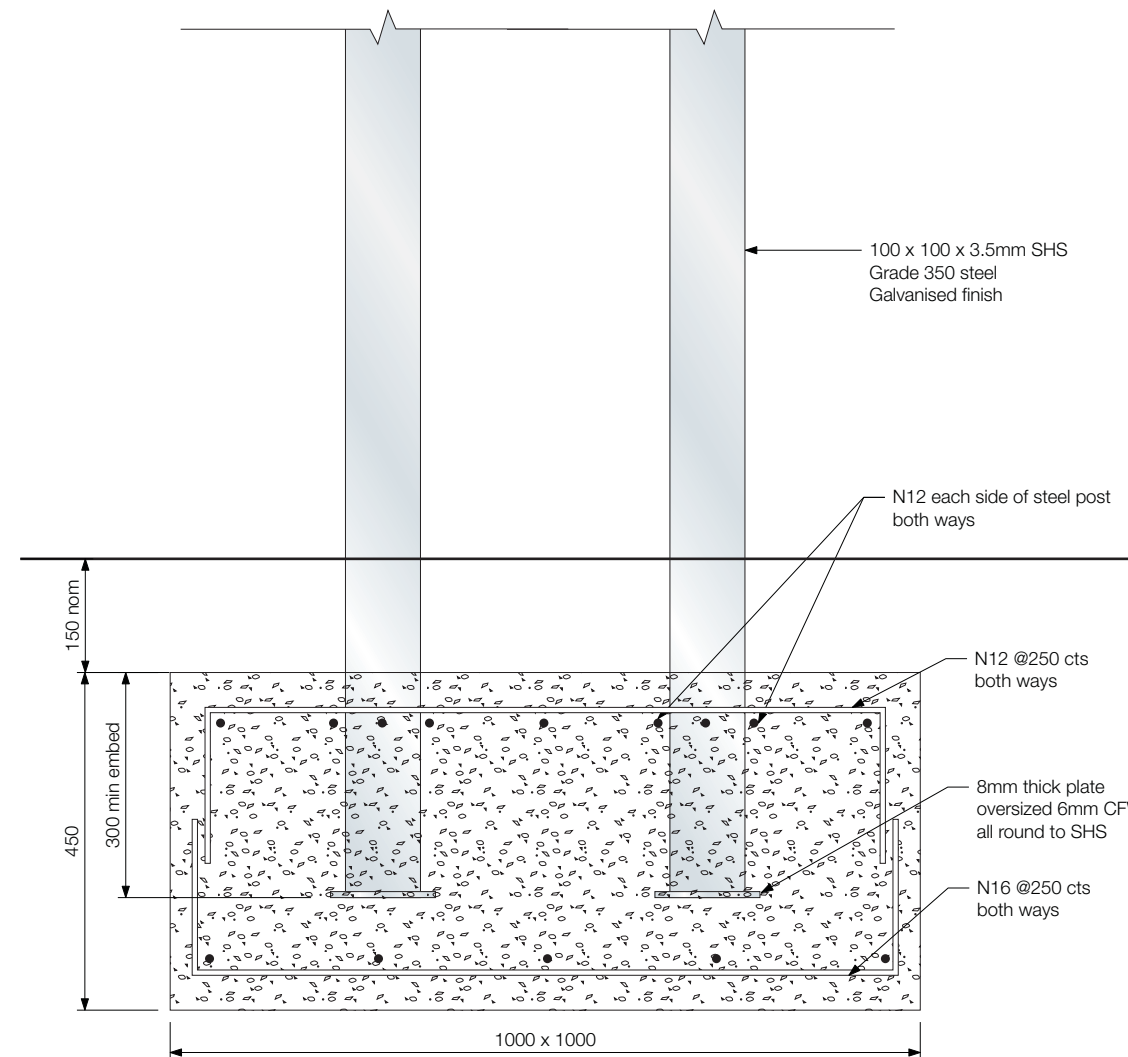

Direct Embed Footing Detail

Scale 1:10

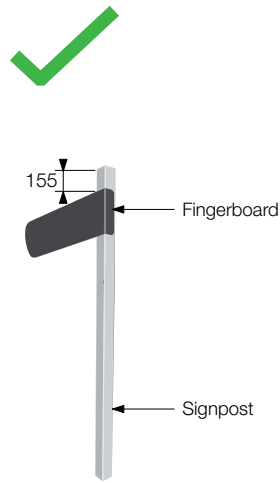

Single Fingerboard

Single directional fingerboard can point in any direction but top edge of fingerboard must be located 155mm from top of sign post

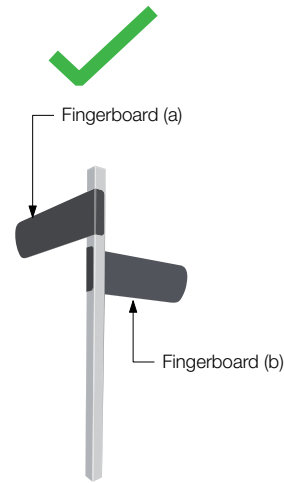

Two Fingerboards 90°

If there are two sign fingerboards at 90° to each other (a) (b), fingerboard (b) is located under fingerboard (a)

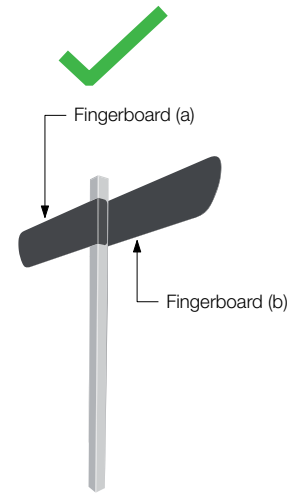

Two Fingerboards 180°

If there are two sign fingerboards at 90° to each other (a) (b), fingerboard (b) is located under fingerboard (a)



Three Fingerboards

A three directional layout always has two sign fingerboards sitting above a single fingerboard



Four Fingerboards

A four fingerboard sign has two fingerboards (180° to each other) at the top of the sign post and another two (180° to each other) underneath

GENERAL CONSTRUCTION NOTES

- Refer to sheet 1 for Single Sided Arrangement
- Refer to sheet 2 for Double Sided Arrangement
- Refer to sheet 3 for Construction details
- Refer to sheet 4 for Graphic layout details
- Refer to sheet 5 for Footing details

ALLOWED

Correct application for Directional Fingerboards

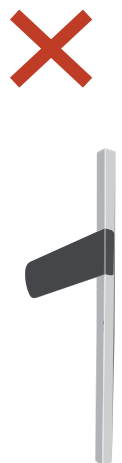

Single Fingerboard

The top edge of the single fingerboard should not sit lower than 155mm from the top edge of the sign post.



Two Fingerboards 90°

Two fingerboards at 90° should not sit on the same level



Two Fingerboards 180°

Two fingerboards at 180° should not sit on different levels



Three Fingerboards

A single fingerboard must not sit above two other fingerboards in a three directional layout



Four Fingerboards

Fingerboards should not sit 90° from each other on the same level

NOT ALLOWED

This configuration is not allowed and will not be accepted.

GENERAL CONSTRUCTION NOTES

- Refer to sheet 2 for Construction details
- Refer to sheet 3 for Graphic layout details
- Refer to sheet 4 for Above ground install
- Refer to sheet 5 for Direct embed install

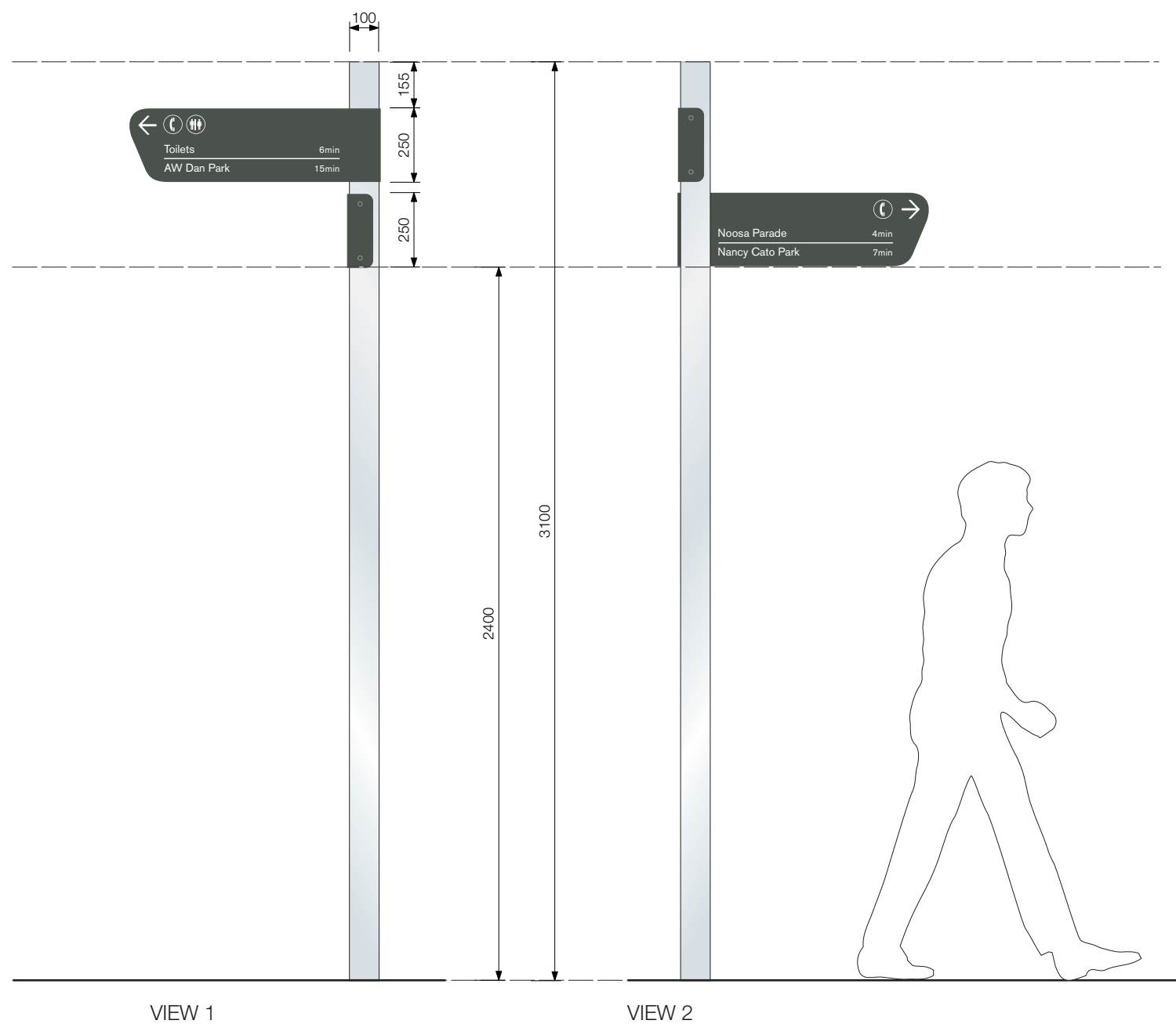

Elevations

Scale 1:20

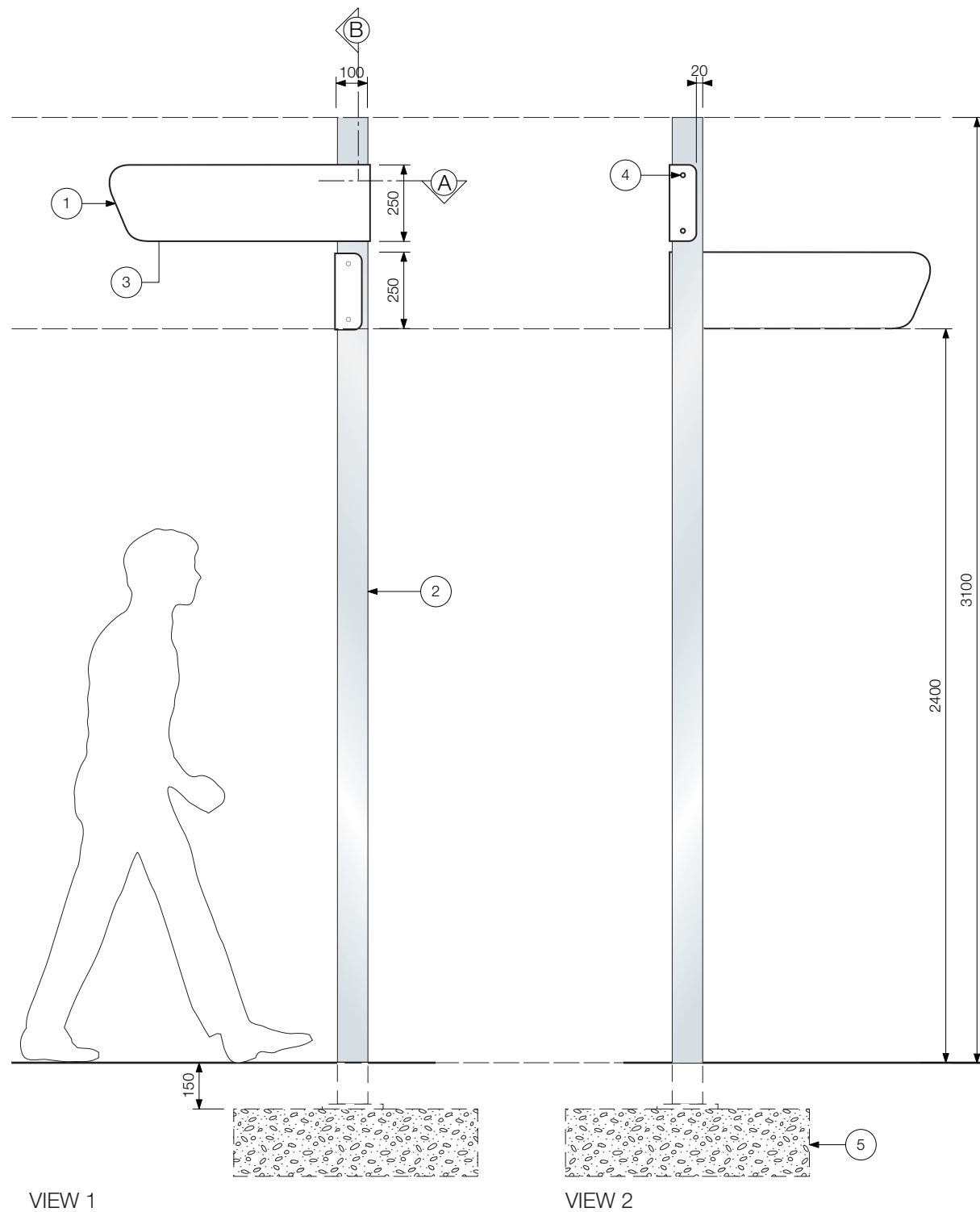

VIEW 1

VIEW 2

Elevations

Scale 1:20

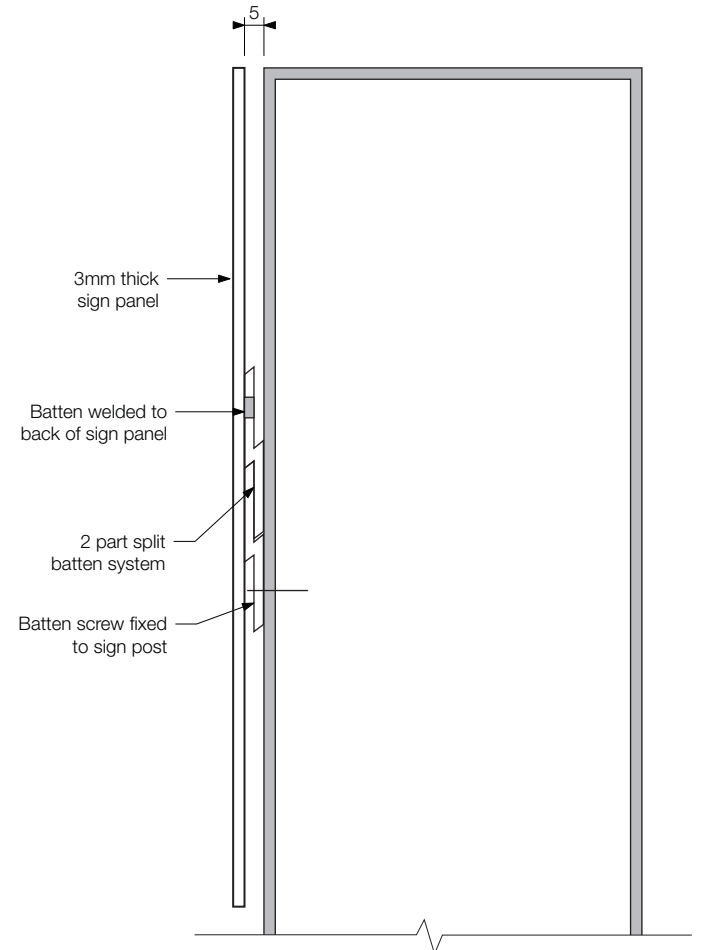

Section B

Scale 1:2

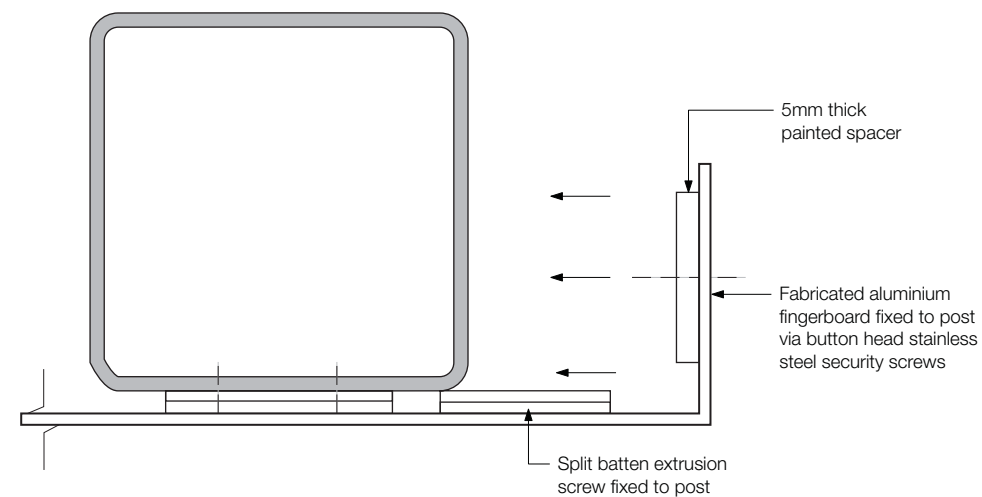

Section A

Scale 1:2

GENERAL CONSTRUCTION NOTES

- Refer to sheet 1 for General arrangement
- Refer to sheet 3 for Graphic layout details
- Refer to sheet 4 for Above ground install
- Refer to sheet 5 for Direct embed install
- Drawings show design intent. Any changes to specification which affects design intent must be approved by the SCRC Project Representative.
- All structural members, fixings and/or footings to be confirmed by sign maker's engineer.
- Signmaker to confirm all details for approval on shop drawings prior to manufacture.

Construction Details

1. 3mm thick fabricated aluminium sign panel with folded return. Fix 5mm thick spacer to panel edge.
2. 100 x 100 x 3.5mm SHS grade 350 post with fully welded base plate and 6mm thick capping. 6mm CFW 220 x 220 x 16mm thick base plate. Galvanised finish.
3. Full colour, high quality digital print direct to premium 5-year polymeric external vinyl. Signmaker to provide manufacturer's warranty. To be printed on flatbed printer.

Vinyl to be front applied to both sides and folded to return. Vinyl to be cut and trimmed to outer shape of sign panel edge.

Nikkalite anti-graffiti overlay film NI-EF 40801-12-45 or equivalent (low gloss finish) to be applied over included folded return.

4. Sign panel fixed to post via security fixings. Post hexagon Socket countersunk head machine stainless steel fixing on return edge. Signlink Split Batten LB to provide a support to post. Refer detail.

5.a FOOTING OPTION 1 - BELOW GROUND

Footing to be 150mm nominal to coordinate with paving. Reinforced concrete pad/pier footing to signmakers' engineer specification. All fixings shall be below ground level to reduce trip hazards. Re-instate / make good paving or pavement, with no changes of level greater than 3mm and no gradients steeper than 1:40.

5.b. FOOTING OPTION 2 - ABOVE GROUND

Mechanical anchors to existing concrete slab. Leveling grout as required. Fixing via M12 hold down bolts with stainless steel dome head nuts. Site inspection to confirm suitability of slab prior to installation.

Material Finish

Steel post = Galvanised finish

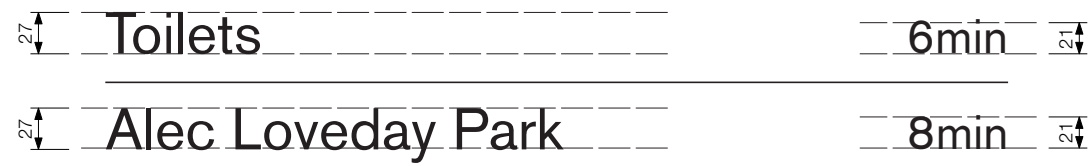
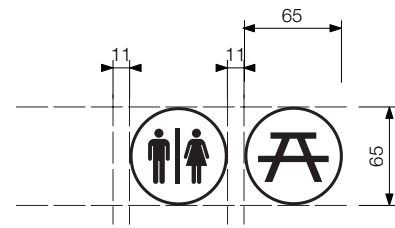

GENERAL CONSTRUCTION NOTES

- Refer to sheet 1 for General arrangement
- Refer to sheet 2 for Construction details
- Refer to sheet 4 for Above ground install
- Refer to sheet 5 for Direct embed install

Graphic Details

FONT

All text = Berthold Akzidenz Grotesk Regular

COLOUR

Sign panel background = Dulux Woodland Grey®

Directional message = White

Pictograms - Refer to Pictogram standards for details

Typical Graphic Layout

Scale 1:5

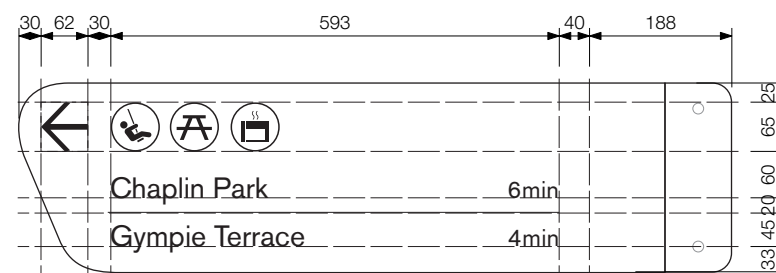
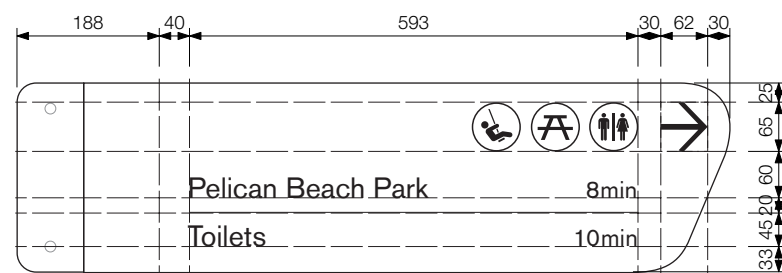
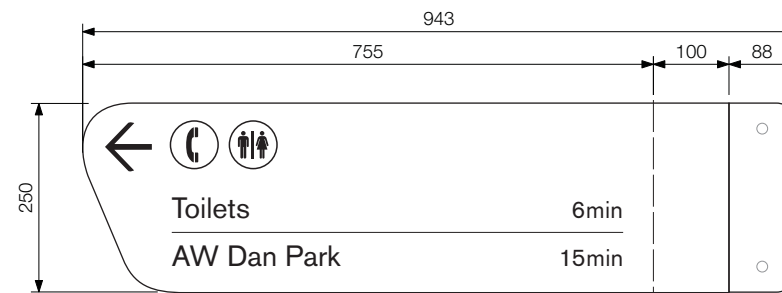
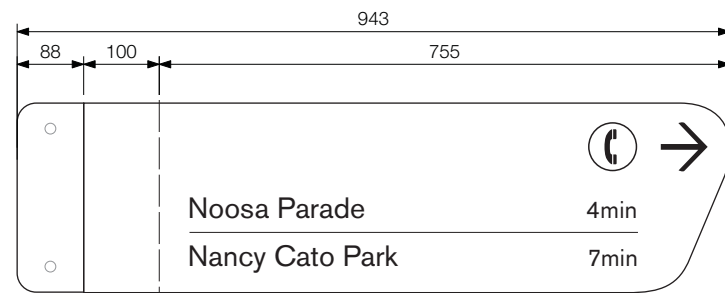

RIGHT DIRECTION

LEFT DIRECTION

Typical Graphic Layouts

Scale 1:10

GENERAL CONSTRUCTION NOTES

- Refer to sheet 1 for General Arrangement
- Refer to sheet 2 for Construction details
- Refer to sheet 3 for Graphic details
- Refer to sheet 5 for Direct embed footings

Note

- Specifications shown are for preliminary advice only.
- All structural members, fixings and/or footings to be confirmed by sign maker's engineer.

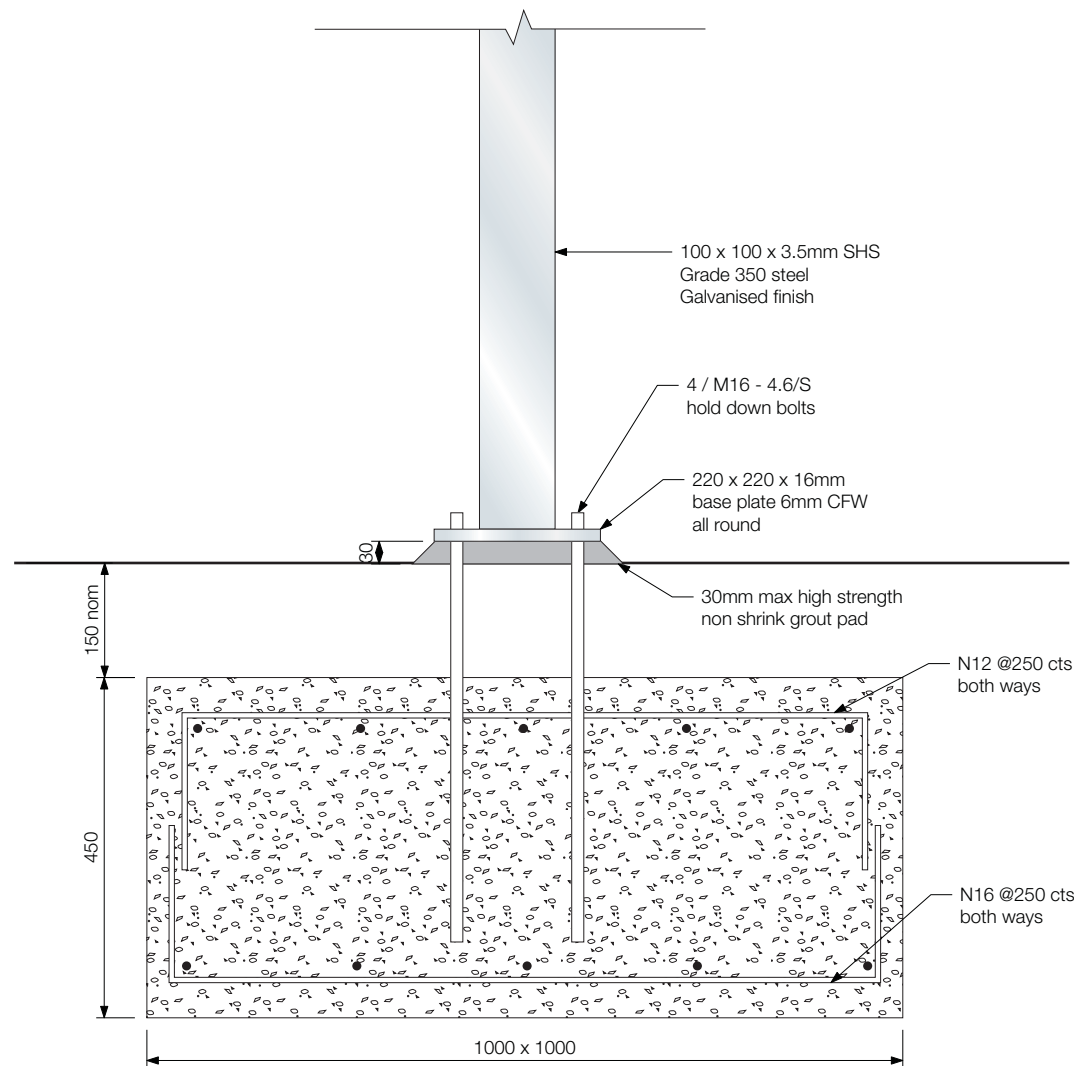

Option 1 - Pad footing

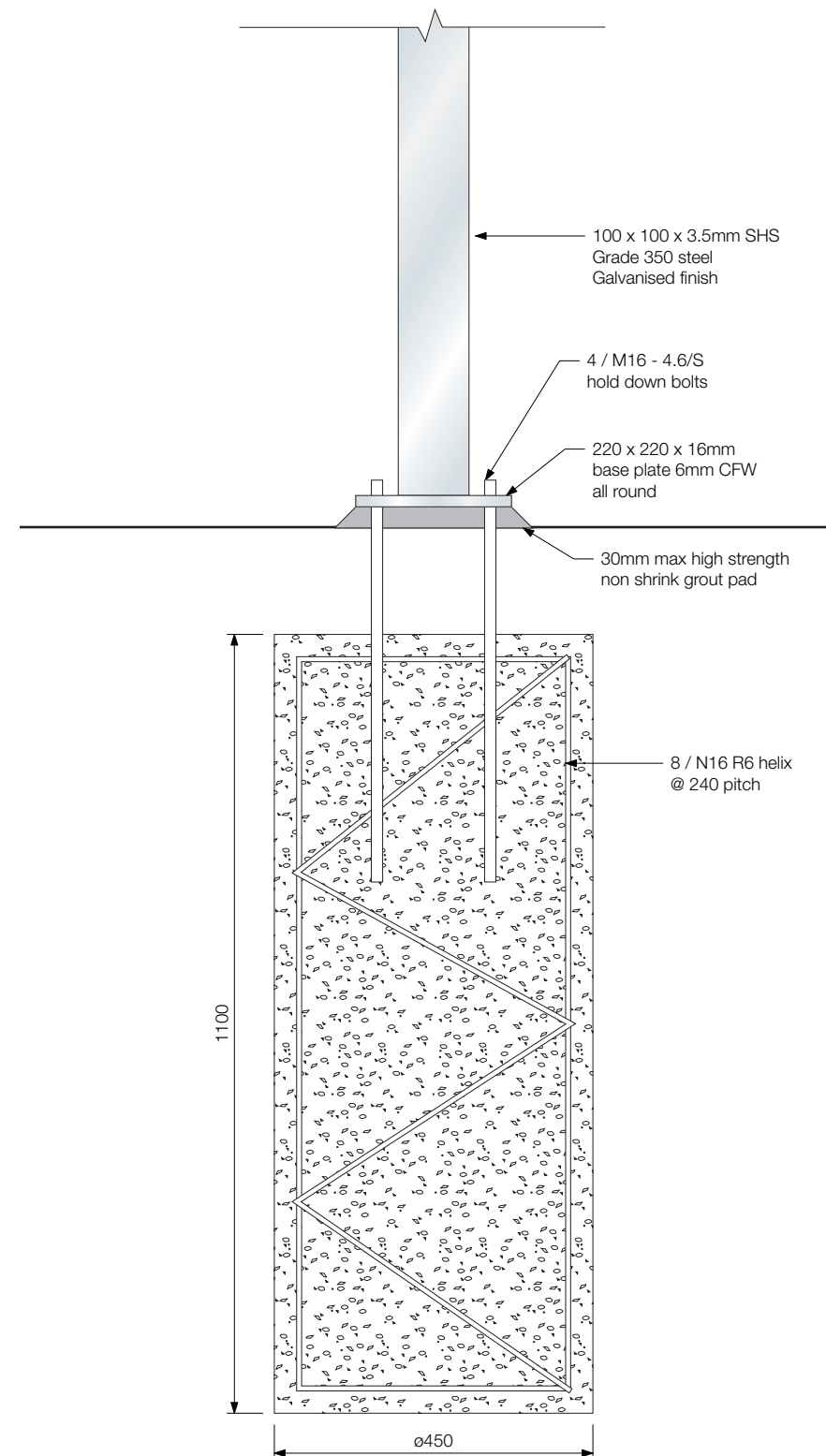

Option 2 - Pier footing

Above Ground Footing Detail
 Scale 1:10

GENERAL CONSTRUCTION NOTES

- Refer to sheet 1 for General Arrangement
- Refer to sheet 2 for Construction details
- Refer to sheet 3 for Graphic details
- Refer to sheet 4 for Above ground footings

Note

- Specifications shown are for preliminary advice only.
- All structural members, fixings and/or footings to be confirmed by sign maker's engineer.

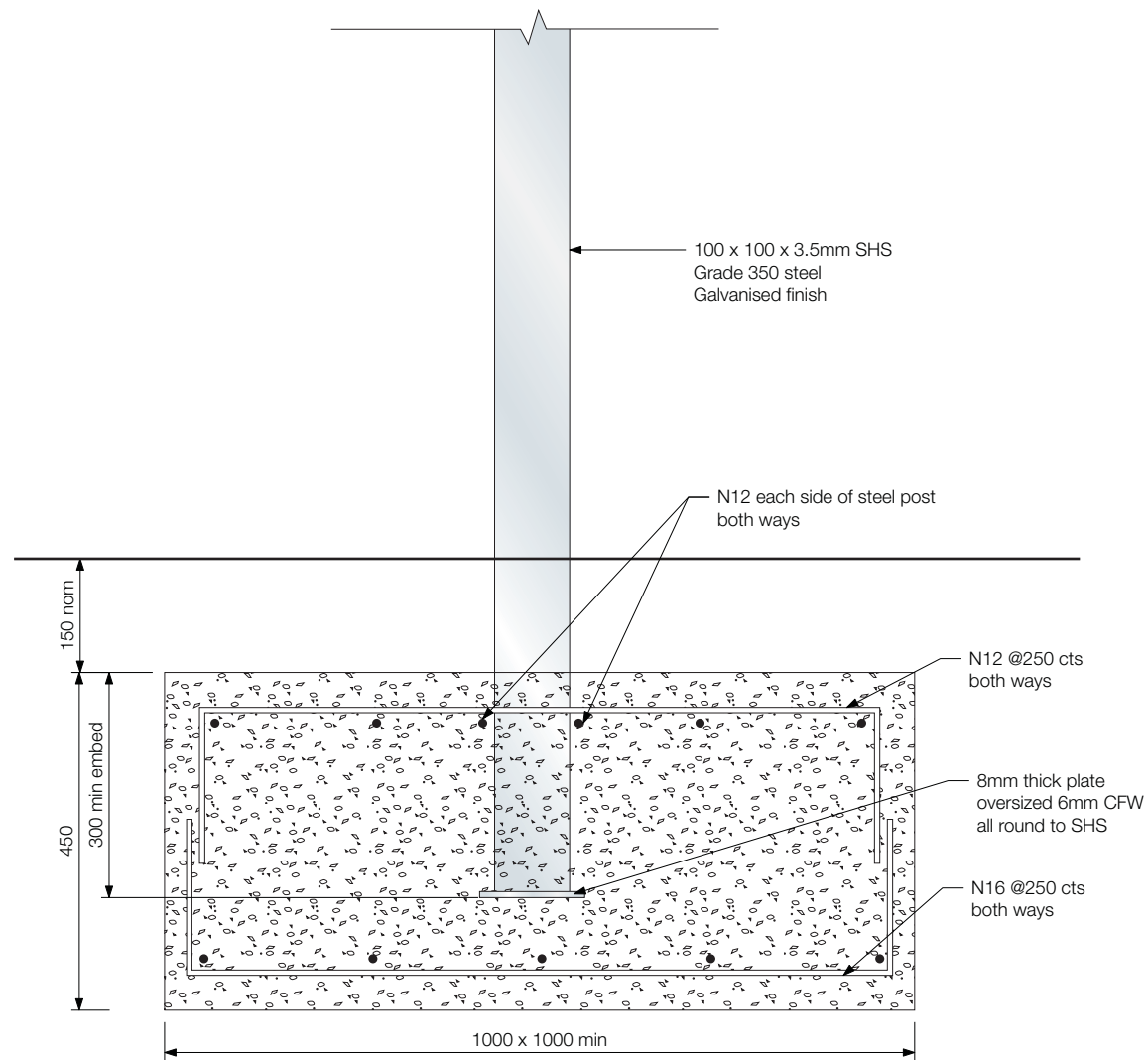

Option 1 - Pad footing

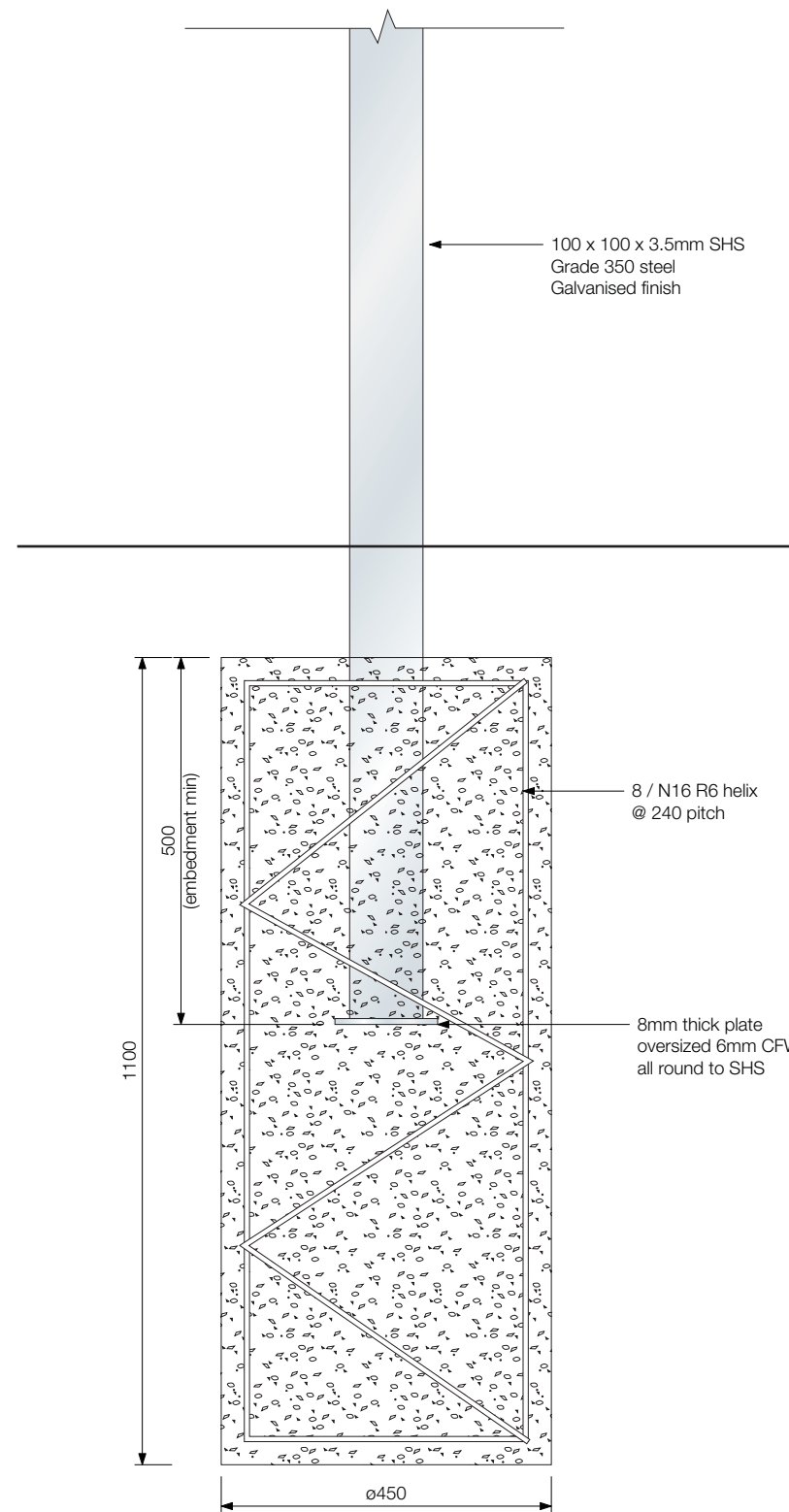

Option 2 - Pier footing

Direct Embed Footing Detail

Scale 1:10

GENERAL CONSTRUCTION NOTES

- Refer to sheet 1 for General Arrangement
- Refer to sheet 2 for Construction details
- Refer to sheet 3 for Graphic details
- Refer to sheet 4 for Above ground footings
- Refer to sheet 5 for Direct embed footings

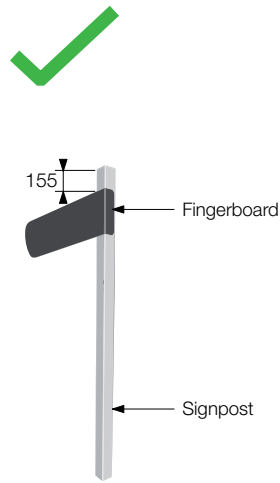

Single Fingerboard

Single directional fingerboard can point in any direction but top edge of fingerboard must be located 155mm from top of sign post

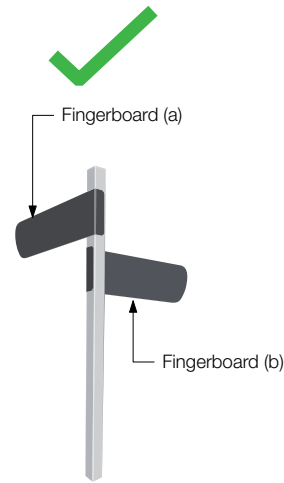

Two Fingerboards 90°

If there are two sign fingerboards at 90° to each other (a) (b), fingerboard (b) is located under fingerboard (a)

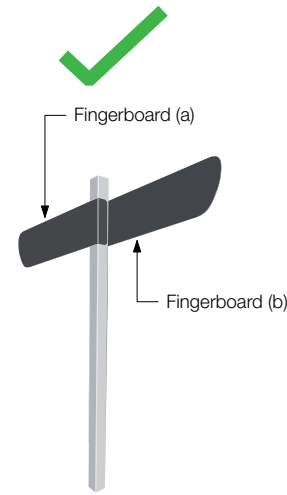

Two Fingerboards 180°

If there are two sign fingerboards at 90° to each other (a) (b), fingerboard (b) is located under fingerboard (a)



Three Fingerboards

A three directional layout always has two sign fingerboards sitting above a single fingerboard



Four Fingerboards

A four fingerboard sign has two fingerboards (180° to each other) at the top of the sign post and another two (180° to each other) underneath

ALLOWED

Correct application for Directional Fingerboards

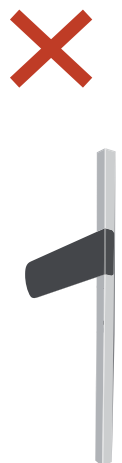

Single Fingerboard

The top edge of the single fingerboard should not sit lower than 155mm from the top edge of the sign post.



Two Fingerboards 90°

Two fingerboards at 90° should not sit on the same level



Two Fingerboards 180°

Two fingerboards at 180° should not sit on different levels



Three Fingerboards

A single fingerboard must not sit above two other fingerboards in a three directional layout



Four Fingerboards

Fingerboards should not sit 90° from each other on the same level

NOT ALLOWED

This configuration is not allowed and will not be accepted.



APPLICATION

Preparing a Sign Program
Sign Location Plan Example
Sign Schedule Example

A Sign Program is required when planning wayfinding for new and existing sites. Once completed it is packaged along with documentation drawings provided in this manual and handed over to a sign maker.

A wayfinding program is created by following this process:

1. Research – Understand the site

The first stage is based around getting to know the site and the various destinations within it. Based on consultation with relevant stake holders (including landscape architects of a new or re-developed site) an understanding should be attained in respect to the wayfinding needs of all user groups. During this stage, things that should be taken into account include; viewing site lines and distance, landscape features, coordination with other signs and consistency throughout the site.

2. Planning – Visual communication in the built environment

In order to create an effective and coherent communication system throughout a site, all locations where information is required, should be identified based on the understanding of visitor requirements and should reference the Wayfinding Signage Principles. Next, the type of information required at each location should be determined and sign type/s assigned to each location.

The following pages describe the Sign Location Plan and Sign Schedule.

Sign Location Plan Example



The first stage is to prepare a Sign Location Plan showing the location of all signs. This should be based on an accurate plan of the site.

Study the site and refer to the Wayfinding Strategy and Plans in Section A to determine which signs are required and where. Also refer to each Sign Type Drawing from the selected Signage Suite to determine the purpose and location of each sign type.

Sign Location Number

The sign location is numbered numerically beginning with the prefix for that particular town or city centre. This provides each sign with a unique number.

Town Prefix



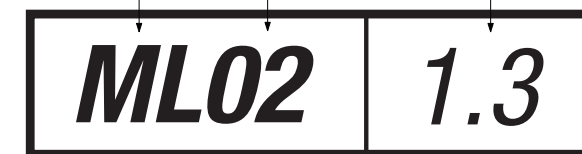

- ML Mooloolaba
- NJ Noosa Junction
- NB Nambour

Sign Type (Suite)

Sign Number



Sign Schedule Example

<p>Sign Location Number ML01</p> <p>Sign Type 1.1</p> <p>Revision – Issue C Message to be confirmed</p> <p>Notes Review of pedestrian circulation to ensure appropriate space. Land ownership and power access to be confirmed by Council</p>		<p>SIDE 1</p> <p>↑ <PPB><PA><PMF></p> <p>Mooloolaba Beach Brisbane Road Toilets</p> <p><Map></p>	<p>SIDE 2</p> <p>↑ <PPB><PLO> HMAS Brisbane Memorial Lookout Alexandra Headland Beach</p> <p><Map></p>	
<p>Sign Location Number ML02</p> <p>Sign Type 1.3</p> <p>Revision – Issue C Message to be confirmed</p> <p>Notes -</p>		<p>FINGER 1</p> <p>Side 1 <PINF><PPB> → Mooloolaba Beach Tourist Information</p> <p>Side 2 <PINF><PPB> ← Mooloolaba Beach Tourist Information</p>	<p>FINGER 2</p> <p>Side 1 <PTR> → Mooloolaba Esplanade Taxi Rank</p> <p>Side 2 <PTR> ← Mooloolaba Esplanade Taxi Rank</p>	
<p>Sign Location Number ML03</p> <p>Sign Type 1.2</p> <p>Revision – Issue C Message to be confirmed</p> <p>Notes Review of pedestrian circulation to ensure appropriate space</p>		<p>SIDE 1</p> <p>↑ <PPB><PINF><PA><PMF> Mooloolaba Beach Brisbane Road Tourist Information Toilets</p> <p>→ First Avenue</p>	<p>SIDE 2</p> <p>↑ <PTR><PLO> Taxi Rank HMAS Brisbane Memorial Lookout</p> <p>← First Avenue</p>	
<p>Sign Location Number ML04</p> <p>Sign Type 1.3</p> <p>Revision – Issue C Message to be confirmed</p> <p>Notes -</p>		<p>FINGER 1</p> <p>Side 1 <PTR> ← Mooloolaba Esplanade Taxi Rank</p> <p>Side 2 <PTR> → Mooloolaba Esplanade Taxi Rank</p>	<p>FINGER 2</p> <p>Side 1 <PPB><PA><PMF> ← Mooloolaba Beach Toilets</p> <p>Side 2 <PPB><PA><PMF> → Mooloolaba Beach Toilets</p>	

The next stage is to prepare a Sign Schedule listing all the signs shown on the Sign Location Plan. The schedule may be generated as a database document and should code the signs and provide the following minimum information:

- Sign type code (e.g. ML02);
- Sign number (e.g. 1.3);
- Location reference or photograph;
- Side 1 message;
- Side 2 message (if required);
- Specific notes about the sign.

The message must follow the standard nomenclature established in this manual and include pictograms wherever possible. Refer to the Wayfinding Signage Principles in Section A and the Graphic Standards in Section D for each sign type in the manual to determine the correct message.

1. Number sign: Site prefix (e.g. ML) followed by the number of that sign within the site (e.g. 09 - the 9th sign within Mooloolaba), i.e. ML09.

2. Choose the most appropriate sign type (reference Section B), e.g. S1.2

3. Provide Revision Issue number. Add notes if necessary, for example concerning installation or location.

4. Provide photograph or detail plan information showing location and context.

5. Note if the sign is one or two sided. Detail the message to be applied to the sign on both sides. Refer to Section D for nomenclature, naming conventions and pictograms.

Once the schedule of signs is completed, total up the signs based on each sign type. Create a list of the sign types required and extract the relevant pages from the sign manual. Ensure the construction details for each sign type are included.

MAINTENANCE

General Cleaning and Graffiti Removal



General Cleaning

Step 1 – Wipe clean with mild detergent and soft lint free cloth.

Step 2 – When panels have dried, apply furniture polish ('Mr Sheen' or similar). DO NOT use abrasive cleaners, solvents or chemicals.

Touch Up Paint

Use only 2 pac polyurethane paint (in the specified colours) when repairing minor chips, cracks, etc. For major damage, panels will need to be removed and sprayed professionally.

Graffiti Removal

General procedure as outlined below:

Step 1 – Use general purpose thinners such as Acetic Acid Alcohol, Toluene or IPA (Isopropyl Alcohol) to clean graffiti from the surface.

Step 2 –Wipe off with clean white rag (Do not re-use dirty rags). If more than 2 applications are needed to remove stubborn stains, rinse the area with clean water and wipe dry before additional application.

Step 3 – Rinse all cleaned surfaces with water.

Step 4 – Allow surface to dry. Disregard used rags in closed container.



SIGN SPECIFICATION

Codes and Standards

Quality Management

Fabrication, Finishes and Installation

Construction Standards

Graphic Standards

Installation Standards

Codes and Standards

All work and materials shall comply with the Building Code of Australia, the Workplace Health and Safety Act, and, except where otherwise noted in this Specification, comply with the latest editions of all relevant Australian codes or standards (current issue) of which the following is a selected list:

Quality Management

AS/NZS ISO 9001 Quality systems for design/ development, production, installation and servicing

METALWORK

AS 1170.2-2002 Minimum design loads on structures – wind loads

AS 1627 Metal finishing – preparation and pre-treatment of surfaces

Part 1 – cleaning using liquid solvents and alkaline solutions

Part 2 – power tool cleaning

Part 4 – abrasive blast cleaning

Part 7 – hand tool cleaning of metal surfaces

Part 9 – pictorial surface preparation standards for painting steel surfaces

AS/NZS 4680 Hot-dip galvanised (zinc) coatings on fabricated ferrous articles

AS 1734 Aluminium and aluminium alloys, flat sheet, coiled sheet and plate

CONCRETE

AS 3600 Concrete structures

AS 3610 Formwork for Concrete

FASTENERS

AS 1214 Hot dip galvanised coatings on threaded fasteners

AS 1420 ISO metric hexagon socket head cap screws

AS 1421 ISO metric hexagon socket set screws

AS 1427 ISO metric machine screws

SEALANTS

AS 1527 Two-part polysulphide based sealing compounds for the building industry.

AS 001543a Sealing compound silicone rubber base (US specification)

PAINTS AND COATINGS

AS 2310 Glossary of paint and painting terms

AS 2312 Guide to the protection of iron and steel against exterior atmospheric corrosion

AS 2700 Colour standards for general purposes

ASTM 03363 Test method for film hardness by pencil

Fabrication, Finishes and Installation

In conformity with the current applicable Australian Standard Code. All materials shall be new, the best of their respective kind and suitable for their purposes. Materials are to be free from corrosion, prime painted and compatible with the final finish, where applicable. Provide all screws, bolts, rivets, pop rivets, plain and countersunk fastenings and washers of a type and material suitable, sufficient and matching in finish and appearance to the components fastened. Unless otherwise specified, comply with the following where applicable.

Properties: Allow for expansion/contraction of materials.

Electrolysis: Provide insulation between dissimilar metals to prevent electrolysis.

Concrete

Concrete for footings shall be of structural quality and free of defect and constructed to Australian Standard Codes for Concrete Reinforcement and Form work. Neat & uniform surrounds where visible.

Aluminium

Aluminium sheet & extruded sections where specified to be used. Single full sheets are to be used for each sign face, there are to be no joints in sheet unless otherwise shown on drawings.

Mild Steel

All mild steel work to be hot dipped galvanised.

Stainless Steel

All stainless steel to be marine grade 316 in sheet form and/or extruded sections as shown on the drawings. Material: Grade 316 stainless steel sheet

Paint

Paint to be 2 pack Polyurethane and applied in accordance with manufacturer's recommendations for spray application. Generic or unbranded products shall not be used. Use only branded premium quality lines from Dulux, Altex, or an equivalent alternative to be approved by the Sunshine Coast Project Representative prior to use.

All material required for the application of each finish must be manufactured by one approved manufacturer and used in conjunction with priming and undercoats produced by that manufacturer as a total coating system.

All signs shall be factory painted using sprayed finishes or other approved finishes. Surfaces to be satin finish (20 to 50 degree gloss level), with full and even cover. Where screws bolts or both are applied to prefinished material, retouch to match.

Paint to be Dulux Acrathane IF 2 pack polyurethane or equal standard and applied as per manufacturers instructions. Primers and undercoats to be applied prior to the final coatings. The final coat to be satin finish (20 to 50 degree gloss level).

Pre-treatment

All materials subject to corrosion shall be suitably primed or otherwise treated with permanent protection. Undercoats shall be evenly applied to concealed frames and supports prior to assembly. Non corrosive materials are to be preferred in all cases.

The Subcontractor shall ensure that all surfaces are properly prepared and in suitable condition to receive the coating system prior to the first application as follows:

- Un-primed or damage primed steelwork shall be abrasive blasted, or power tool cleaned to near white metal, immediately prior to priming or spot priming
- Primed steelwork shall be brushed down and degreased using white spirit
- Galvanised steelwork scheduled to be paint finished shall be degreased using white spirit, and washed with water
- Concrete and masonry surfaces shall be cleaned of all oil, grease and loose foreign matter, including efflorescence and dirt, prior to the application of any paint finishes
- Aluminium should be lightly abraded using fine emery cloth and mineral turpentine as a lubricant. Surfaces should be cleaned with mineral turpentine, washed thoroughly and dried. As soon as surfaces are thoroughly dry, apply self-etching primer to all surfaces. Fine sanding and painting should follow immediately thereafter.

Mixing and Blending

All paints shall be mixed in accordance with manufacturer's recommendations.

Chemically cured coatings shall be blended in exact quantities either by weight or by the use of volume matched containers. Accurate and properly calibrated equipment is required capable of weighing to an accuracy of 5g. The whole contents of volume matched containers shall be blended at once. On no account shall part only of volume matched containers be blended.

Each container shall be thoroughly and separately mixed using clean mixing equipment that has not been in contact with the other containers.

Blended material shall be poured from mixing container; care being taken not to scrape out materials left adhering to the container.

Application shall be carried out within 1 hour of mixing.

Thinning shall only be permitted for spray applications or sealing coats and then only with thinners supplied by the finish manufacturer for this purpose.

Powder Coatings

Powder coatings to meet performance standard AS3715 (Dulux Alphatec Plus or equal standard) and applied as per manufacturers instructions.

Adhesives

Adhesives must be suitable for their application and applied as per manufacturers instructions. Silicone adhesive is to be Dow Corning, Sikaflex or equal standard. The adhesive must meet the following criteria:

- A one part formulation resistant to UV radiation, aging and weathering
- Capable of withstanding high dynamic stresses
- Very low VOC content and not contain silicone, PVC or acetic acid
- High recovery and elastic with low odour, one-part formulation

Double Sided Tape

Double sided adhesive tape is to be 3M brand 4016 or equal.

Vinyl Graphics

Cut from self adhesive vinyl by computer operated flat bed knife cutter.

TYPE - Exterior grade cast vinyl

COLOURS - As noted on the colour reference page. Gloss level to match painted surfaces. Thickness: .08mm to .10mm thickness range
Manufacturer: 3M, Calon or equal standard.

Digital Prints

All digital prints are to conform to the following requirements,

- Final output to accurately reflect supplied artwork
- True solvent inks to be used for digital print applications
- Minimum 200dpi resolution at full size printed on Flatbed printer
- Minimum 5 year outdoor life
- Print inks and substrates to suit application ie. external
- Apply spray clear coat over for UV and graffiti protection.
- Ensure all surfaces are cleaned and prepared prior to application of print
- Finished print to be free of any air bubbles, creases or distortions.
- Cast external grade 5-year polymeric vinyl to be used for external applications. Signmaker to provide manufacturer's warranty.

Screen Printing

Where noted on the drawings, graphics are to be accurately screen printed using silk screens and two pack paints.

Protective anti-graffiti coating

All painted faces shall have a final clear coat applied over the face to protect from graffiti. The clear coat shall be consistent and compatible with the paint finish and applied as per manufacturers instructions.

All signs with vinyl graphics front applied shall have a final clear coat applied over the face to protect the vinyl from scratching. A clear coat shall consist of four sprayed layers of clear non yellowing two pack polyurethane paint

Sacrificial Coatings

Sacrificial anti-graffiti clear coat over all sign panels, consistent with the paint finish and applied as per manufacturers instructions ('The Graffiti Specialists' or equal).

The final coat to be satin finish (20 to 50 degree gloss level) to match other painted surfaces. Signs not matching this standard will be rejected through sampling process.

Fixings

Materials subject to anodic reactions must be fixed with suitable hardware to eliminate anodic reactions between dissimilar metals. Fixings must suit design requirements ie. galvanised, zinc coated bolts to fix to galvanised structures.

- Tek-screw type fixings are not permitted where visible.
- Stainless steel fixings to be grade 316 with anti-theft heads as shown on drawings.

Construction Standards

Generally

Form graphics items accurately to the specified shapes and surfaces with clean, well defined edges or arrises, free from blemishes. The Subcontractor shall be responsible for the quality of all materials and workmanship required to manufacture the signs including the materials and workmanship of any firms or individuals who act on behalf of the Subcontractor and/or suppliers.

Construction Standards

Construction is to be of the highest of industry standards. Where connection or suspensions are made, plates, bolts, angles and screws are to be concealed as much as possible from view unless otherwise detailed. Box frames or tube shall be extruded and prefinished. Spaces, drilled holes and fixings shall be consistent from one sign to another. Screws, adhesives and

silicones shall be concealed and or made flush with the surface. Fit components with care. Graphic standards are to be carefully adhered to.

Structural Support

Structural support of signs shall be independent of the existing structure except where specifically fixed to walls, floors or ceilings. For all signs, the Subcontractor is to be responsible for strength and suitability of the structural support and connection of all signs. Where visible plinths are shown on the sign drawings, match details as shown. Internal structure may be amended to suit relevant structural requirements.

Cut out Shapes

Cut out shapes must be accurately pantographed or laser cut from solid material and hand finished as necessary. Fixing pins to be drilled & tapped into back of each shape, minimum 2 per shape/letter.

Fabrication

For metals weld lines where visible are to be ground back and polished.

Welding

All welding and welding equipment shall satisfy the requirement of the appropriate standards for the specified material and conform to SAA code. All visible welds to be neat, ground back and polished.

Warranty

The signs shall not show deterioration, fading, crazing, peeling or bond failure for a period not less than (5) years from the date of completion.

Graphics Standards

Sign messages are to be created from electronic artwork to faithfully reproduce the shapes and typefaces specified. The graphic layouts shall follow the guidelines outlined in the Sign Type Drawings.

Graphics shown on the Sign Type Drawings as Illustrator .ai or .eps files in Macintosh format. These will be provided on CD ROM for pick up by the sign maker or sent via e-mail.

It is the responsibility of the sign maker to ensure that all electronic files are accurately converted and match the SignType Drawings provided in form, size & colour. Hard copy drawings provided are to be used as the primary reference.

If the Subcontractor finds any text messages or graphics that are not catered for in the Sign Type Drawings, the Subcontractor shall prepare a layout of the message at a minimum 1:10 scale and submit the layout for approval prior to production.

Graphic Standards

The following rules of graphic quality apply:

1. All lettering shall be true to its letter form in face weight and construction.
2. All graphics are to be electronically, photographically or mechanically reproduced.
3. All colours are as specified in Pantone colour reference system or other specified colour.

Typeface

The font Berthold Akzidenz Grotesk as shown on the sign type drawings and Graphic Standards is to be used for all messages, text and numerals except where specifically stated otherwise. No other versions of typefaces will be accepted. It is the responsibility of the sign maker to purchase the font(s) as specified.

Pictograms and Arrows

Only the symbols as shown on the sign type drawings are to be used. No other versions will be accepted.

Colours

Colours for all parts and faces are as noted on the drawings.

Installation Standards**Site Conditions**

Site inspections are to be carried out prior to installation to verify locations, confirm all architectural details, mounting conditions and dimensions.

General

All installations to be plumb and level, at the heights indicated, securely mounted with theft-resistant fixings. Locate all signs in the correct position and orientation as indicated on Sign Location Plans & Schedules.

Work shall be complete with all bolts, rivets and other fittings to adequately transmit the loads and stresses imposed. Where bolting of metal work to concrete is specified, fixings to be of approved masonry anchors of the required size. Proper edge clearances should be observed so there is no risk of possible damage to concrete or structural framing. Packing of fixings is permitted to approved tolerances to level and square installations.

APPENDIX A

Blank Sign Schedule Templates

Sign Location
Number

Sign Type

Specific Notes

Location reference - photograph or note

SIDE 1

SIDE 2



side 1 side 2

Location reference - photograph or note

Sign Location
Number

Sign Type

Specific Notes

Location reference - photograph or note

SIDE 1

SIDE 2



side 1 side 2

Location reference - photograph or note

Sign Location Number

Sign Type

Specific Notes

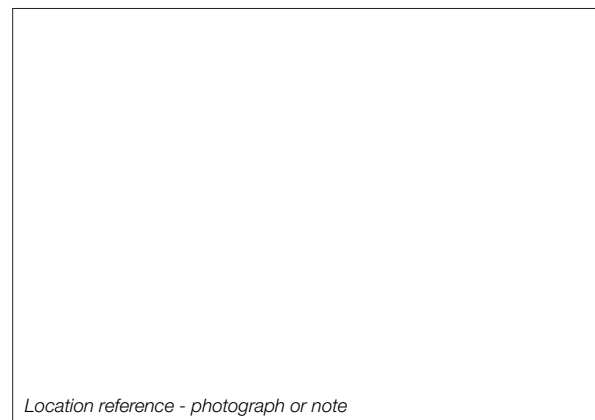

Location reference - photograph or note

FINGER 1

Side 1

FINGER 2

Side 1

FINGER 3

Side 1

FINGER 4

Side 1

Side 2

Side 2

Side 2

Side 2

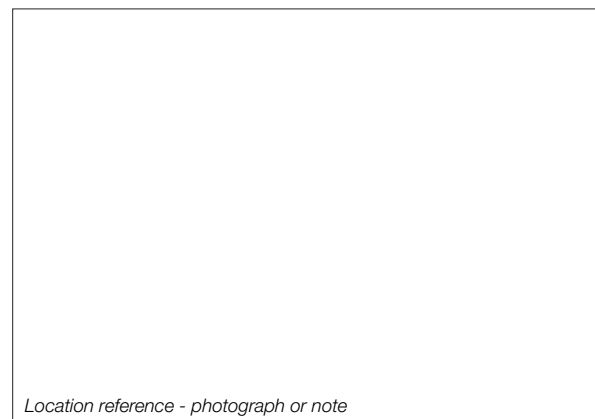
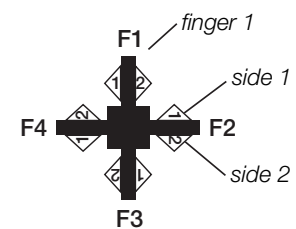

Location reference - photograph or note

Sign Location Number

Sign Type

Specific Notes

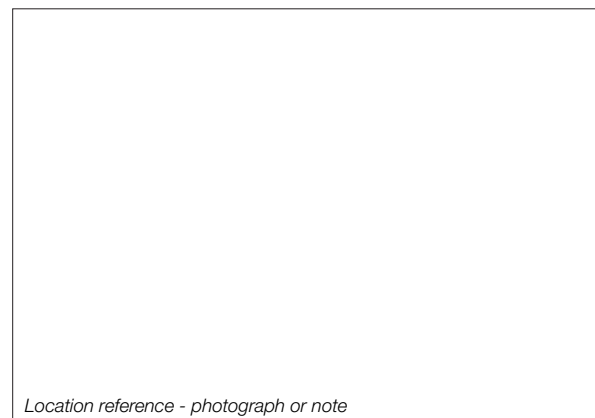

Location reference - photograph or note

FINGER 1

Side 1

FINGER 2

Side 1

FINGER 3

Side 1

FINGER 4

Side 1

Side 2

Side 2

Side 2

Side 2

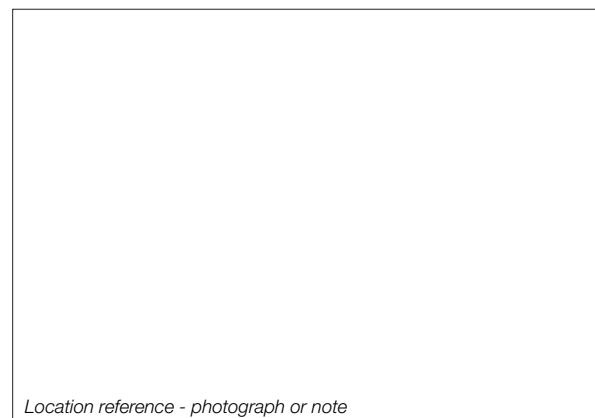
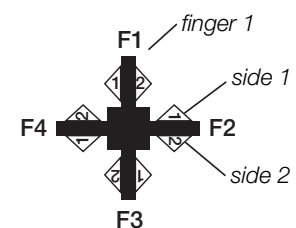

Location reference - photograph or note

APPENDIX B

Engineer Reports

PROPOSED WAYFINDING SIGNAGE FOR: SUNSHINE COAST REGIONAL COUNCIL

GENERAL

- G1. READ THESE DRAWINGS IN CONJUNCTION WITH ARCHITECTURAL AND OTHER ENGINEERING DRAWINGS AND SPECIFICATIONS AND WITH SUCH OTHER WRITTEN INSTRUCTIONS AS MAY BE ISSUED.
- G2. VERIFY SET OUT DIMENSIONS SHOWN ON THE DRAWINGS BEFORE SITE WORKS, CONSTRUCTION AND FABRICATION COMMENCES. REFER ANY DISCREPANCY TO THE ENGINEER BEFORE PROCEEDING WITH THE WORK.
- G3. DO NOT OBTAIN DIMENSIONS BY SCALING FROM THE DRAWINGS.
- G4. ALL WORKMANSHIP AND MATERIALS SHALL BE IN ACCORDANCE WITH THE CURRENT S.A.A CODES AND THE BY-LAWS AND ORDINANCES OF THE RELEVANT BUILDING AUTHORITY.
- G5. THE STRUCTURAL WORK SHOWN ON THE DRAWINGS HAS BEEN DESIGNED FOR THE LOADS SET OUT IN THE TABLE BELOW IN ACCORDANCE WITH AS 1170 PARTS 1 & 2.
- G6. ALL STRUCTURAL WORK MUST BE INSPECTED AND APPROVED BY THE ENGINEER.
- G7. FORTY-EIGHT (48) HOURS NOTICE MUST BE GIVEN TO THE ENGINEER PRIOR TO ANY CONCRETE POURS OR OTHER SIMILARLY CRUCIAL PHASES OF CONSTRUCTION.

GENERAL CONTINUED

- G8. THE DOCUMENTED DESIGN IS STABLE FOR THE FINAL AS-BUILT CONDITION OF THE STRUCTURE, WITH ALL STRUCTURAL ELEMENTS, BRACING AND CONNECTIONS IN PLACE. THE MEANS, METHODS, TECHNIQUES, SEQUENCES, TEMPORARY WORKS AND SAFETY MEASURES REQUIRED TO EXECUTE THE WORKS AND MAINTAIN STABILITY OF THE PARTIALLY COMPLETED STRUCTURE REMAIN THE RESPONSIBILITY OF THE BUILDER. THE BUILDER IS RESPONSIBLE FOR ENGAGING A QUALIFIED (REGISTERED ENGINEER QLD AND VIC) TO DESIGN, CERTIFY AND INSPECT THE TEMPORARY WORKS. NO TEMPORARY PROPPING OR FALSEWORK IS TO BE REMOVED WITHOUT INSPECTION AND WRITTEN APPROVAL FROM A REGISTERED (VIC AND QLD) ENGINEER.

FOOTING & FOUNDATION PREPARATION

- F1. PREPARE EXISTING FOUNDATION BELOW THE BUILDING BY REMOVAL OF ANY TOPSOIL CONTAINING ORGANIC AND/OR INORGANIC MATTER WHICH MAY INHIBIT COMPACTION.
- F2. DEEPEN FOOTINGS AND SLAB STIFFENING BEAMS TO BEAR ON FOUNDATION MATERIAL WITH MINIMUM SAFE BEARING PRESSURE AS NOTED IN THE TABLE BELOW LEFT.
- F3. COMPACT FOUNDATION BELOW THE CONCRETE SLABS TO THE STANDARD OF COMPACTION FOR FILL UNDER SLABS OR FOOTINGS HEREUNDER UNLESS NOTED OTHERWISE.
- F4. SAND FILLING UNDER SLABS OR FOOTINGS SHALL BE PLACED IN MAX. 200mm LAYERS. (UNCOMPACTED DEPTH) COMPACTED IN ACCORDANCE WITH AS 1289 (DENSITY INDEX TO BE GREATER THAN 70% IN ACCORDANCE WITH AS 1289).
- F5. FILL MATERIAL OTHER THAN SAND (ie. GRAVEL, DECOMPOSED ROCK OR BROKEN ROCK, FREE FROM ORGANIC MATERIAL AND LUMPS OF CLAY) UNDER SLABS OR FOOTINGS TO BE COMPACTED TO ACHIEVE A DENSITY RATIO (CALCULATED BY AS 1289) OF NOT LESS THAN 98% AT MAXIMUM DRY DENSITY AS DETERMINED BY AS 1289.
- F6. PROOF ROLL THE FOUNDATION AND REMOVE AND RECONSTRUCT AREAS THAT BREAK UP OR SHOW EVIDENCE OF MOVEMENT UNDER THE PROOF LOADING.
- F7. CONSTRUCT FOOTINGS UNDER ALL LOAD BEARING WALLS (TYPICAL).
- F8. LAP AND CORNER BARS EQUIVALENT TO THE REINFORCEMENT IN THE FOOTING TO BE PROVIDED AT CHANGES IN DIRECTION AND JUNCTION OF FOOTINGS.

FOOTING & FOUNDATION PREPARATION CONTINUED

- F9. LARGE TREES ADJACENT TO THE BUILDING ARE TO BE REMOVED. THE VOIDS SHALL BE EXCAVATED, BACKFILLED & COMPACTED WITH SUITABLE MATERIAL SIMILAR TO THE EXCAVATED MATERIAL.
- F10. ALL TREES, PROPOSED OR EXISTING, SHALL NOT BE CLOSER TO THE FOOTING THAN 0.8 TIMES THEIR MATURE HEIGHT. WHERE THIS CAN NOT BE ACHIEVED, BUILDER IS TO SEEK ADVICE FROM ENGINEER.
- F11. TRENCHES FOR SERVICES SHALL BE LOCATED AT A MINIMUM OF 1.0m CLEAR OF FOOTINGS.
- F12. PROPER SITE DRAINAGE & FOUNDATION MAINTENANCE MUST BE STRICTLY OBSERVED TO MINIMISE MOISTURE VARIATIONS IN REACTIVE CLAY SOILS. IT IS THE HOUSE OWNERS RESPONSIBILITY TO BE FAMILIAR WITH & COMPLY WITH THE REQUIREMENTS OF "GUIDE TO HOME OWNERS ON FOUNDATION MAINTENANCE & FOOTING PERFORMANCE." PUBLISHED BY CSIRO.
- F13. REFER TO THE GEOTECHNICAL REPORT AS NOTED IN THE TABLE TO LEFT.

REINFORCED CONCRETE

- C1. ALL CONCRETE WORK AND REINFORCEMENT TO BE EXECUTED IN ACCORDANCE WITH THE RELEVANT S.A.A CODES AND SPECIFICATIONS: IN PARTICULAR THE CURRENT EDITION OF AS 3600.
- C2. CONCRETE COMPONENTS AND QUALITY TO BE N25 (EXPOSURE CLASSIFICATION A1) U.N.O. MAXIMUM AGGREGATE SIZE TO BE 20mm U.N.O.
- C3. CONCRETE TESTING TO CONFORM WITH THE ACCEPTABILITY REQUIREMENTS OF THE CURRENT EDITION OF AS 3600.
- C4. THE CONCRETE SLUMP SHALL NOT BE LESS THAN 75mm AND NOT MORE THAN 100mm.
- C5. ALL CONCRETE SHALL BE ADEQUATELY VIBRATED INTO PLACE, NO WATER TO BE ADDED ON SITE., CURE CONTINUOUSLY FOR NOT LESS THAN SEVEN (7) DAYS IN AN APPROVED MANNER.
- C6. NO HOLES, CHASES OR VOIDS, OTHER THAN THOSE SHOWN ON THE STRUCTURAL DRAWINGS ARE TO BE MADE WITHOUT PRIOR APPROVAL OF THE ENGINEER.

REINFORCED CONCRETE CONTINUED

- C7. SYMBOLS ON DRAWINGS FOR GRADE & TYPE OF REINFORCEMENT ARE AS FOLLOWS:-
 R DENOTES STRUCTURAL GRADE 230 PLAIN ROUND BAR TO AS 4671.
 N DENOTES HOT ROLLED GRADE 500 DEFORMED BAR TO AS 4671.
 SL DENOTES HARD DRAWN WIRE REINFORCING FABRIC TO AS 1304.
 S STRUCTURAL GRADE DEFORMED BARS TO AS 1302.
- C8. MINIMUM LAPS OF REINFORCEMENT (U.N.O.):
 MESH 250mm
 12mm Ø BAR 300mm
 16mm Ø BAR 400mm
- C9. ALL REINFORCEMENT SHALL BE CONTINUOUS WITH THE FOLLOING LAPS AT SPLICE:
 TRENCH MESH 300mm
 FABRIC 250mm
- C10. ALL REINFORCEMENT SHALL BE CHAIRED TO THE SATISFACTION OF THE ENGINEER.
- C10. WHERE BRITTLE FLOOR COVERINGS ARE USED OVER AN AREA GREATER THAN 16m², EXTRA MEASURES SHALL BE TAKEN TO CONTROL THE EFFECT OF SHRINKAGE CRACKING. SUCH MEASURES SHALL INCLUDE ONE OF THE FOLLOWING:

- A THE AMOUNT OF SHRINKAGE REINFORCEMENT SHALL BE INCREASED TO SL92 OR EQUIVALENT THROUGHOUT THE AFFECTED SLAB PANELS. ALTERNATIVELY, AN ADDITIONAL SHEET OF SLAB MESH SHALL BE PLACED OVER AFFECTED AREAS.
- B THE BEDDING SYSTEM FOR BRITTLE COVERINGS SHALL BE SELECTED ON THE BASIS OF THE EXPECTED SLAB MOVEMENT AND THE CHARACTERISTICS OF THE FLOOR COVERINGS.
- C THE PLACEMENT OF FLOOR COVERINGS SHALL BE DELAYED (THREE MONTHS).

STRUCTURAL STEELWORK

- S1. ALL WORKMANSHIP & MATERIALS SHALL BE IN ACCORDANCE WITH AS 4100 & AS 1554 EXCEPT WHERE VARIED BY THE SPECIFICATION.
- S2. ALL STEEL SHALL BE IN ACCORDANCE WITH AS 3679 GRADE 250 OR 300 U.N.O. (AS 1163 GRADE C350 FOR RECTANGULAR & SQUARE HOLLOW SECTIONS OR GRADE 200 FOR CIRCULAR HOLLOW SECTIONS TO 165.1mm O.D. & GRADE C350 ABOVE 165.1mm O.D)
- S3. WELDS SHALL BE TO THE REQUIREMENTS OF AS 1554 & SHALL BE 6mm CONTINUOUS FILLET WELDS UNLESS SHOWN OTHERWISE.
- S4. BUTT WELDS SHALL BE PRE-QUALIFIED COMPLETE PENETRATION BUTT WELDS. ALL WELDS SHALL BE CATEGORY SP IN ACCORDANCE WITH AS 1554 UNLESS NOTED OTHERWISE.
- S5. ALL GUSSET AND CONNECTION PLATES SHALL BE 10mm UNLESS SHOWN OTHERWISE.
- S6. BASE PLATES SHALL BE 16mm UNLESS SHOWN OTHERWISE.
- S7. MINIMUM 5mm RADIUS CUT SHALL BE MADE TO ALL RE-ENTRANT CORNERS.
- S8. ALL INTERNAL STEELWORK IS TO BE MECHANICALLY WIRE BRUSHED TO REQUIREMENTS OF AS 1627.2 AND HAVE 2 COATS OF A ZINC RICH PRIMER PAINT COMPLYING WITH AS 3750.
- ALL EXTERNAL STEELWORK IS TO BE HOT DIPPED GALVANISED. STEELWORK TO BE GALVANISED SHALL BE CLEANED TO REQUIREMENTS OF AS 4680 CLASS 2 1/2 OR BETTER & HOT DIP GALVANISED TO REQUIREMENTS OF AS 4680
- S9. BOLTS TO BE HIGH STRENGTH, SNUG TIGHT TO AS 4100, (I.E. 8.8/S) U.N.O.
- S10. ALL NUTS, BOLTS & WASHERS TO BE GALVANISED.
- S11. HOLDING DOWN BOLTS TO BE SUPPLIED COMPLETE WITH LEVELLING NUTS, NUTS AND WASHERS.
- S12. DAMAGED PAINT WORK & ALL NUTS, BOLTS AND WASHERS SHALL BE CLEANED AND RETOUCHE AFTER ERECTION.
- S13. CONCRETE ENCASED STEELWORK TO BE LEFT UNPAINTED AND BE WRAPPED IN FGW 41 FABRIC UNLESS OTHERWISE SHOWN.

- S14. TWO (2) COPIES OF ALL WORKSHOP DRAWINGS TO BE SUBMITTED TO THE ENGINEER AND APPROVAL OBTAINED IN WRITING BEFORE FABRICATION IS COMMENCED. APPROVAL DOES NOT INCLUDE CHECKING DIMENSIONS.

MAINTENANCE

- MA1. THE OWNERS ATTENTION IS DRAWN TO APPENDIX A OF AS 2870 'PERFORMANCE REQUIREMENTS AND FOUNDATION MAINTENANCE.'
- MA2. LARGE, MOISTURE-ABSORBING TREES ARE NOT TO BE PLANTED IN CLOSE PROXIMITY TO THE FOOTINGS.
- MA3. NATURAL WATER RUN-OFF IS TO BE DIRECTED AWAY FROM SLAB AND PLATFORM GENERALLY.
- MA4. EXCESSIVE WATERING OF GARDENS ADJACENT TO THE HOUSE SLAB IS TO BE AVOIDED, TO MINIMISE ANY GROUND HEAVING.

WIND LOADS:

- REGION: B
- TERRAIN CATEGORY: 2.0
- DESIGN GUST WIND SPEED: N4
- (V₂₀): 41 m/s
- (V₁₀₀): 50 m/s
- (V₅₀₀): 61 m/s

LIVE LOADS:

- BALCONIES: 3.0kPa
- STAIRS: 2.0kPa
- FLOORS: 1.5kPa

MIN. SAFE BEARING PRESSURE:

- 50kPa

GEOTECHNICAL REPORT:

- BY: N/A

FOR CONSTRUCTION

A	ISSUED FOR CONSTRUCTION	22.02.2011	SGT	<p>COPYRIGHT THIS DRAWING IS COPYRIGHT AND THE PROPERTY OF VDM CONSULTING (QLD) PTY LTD. IT MUST NOT BE RETAINED, COPIED OR USED WITHOUT THE AUTHORITY OF VDM CONSULTING (QLD) PTY LTD.</p> <p>DISCLAIMER THIS DRAWING AND ITS CONTENTS ARE ELECTRONICALLY GENERATED, ARE CONFIDENTIAL AND MAY ONLY BE USED FOR THE PURPOSE FOR WHICH THEY WERE INTENDED. VDM CONSULTING (QLD) PTY LTD WILL NOT ACCEPT RESPONSIBILITY FOR ANY CONSEQUENCES ARISING FROM THE USE OF THE DRAWING FOR OTHER THAN ITS INTENDED PURPOSE OR WHERE THE DRAWING HAS BEEN ALTERED, AMENDED OR CHANGED EITHER MANUALLY OR ELECTRONICALLY BY ANY THIRD PARTY.</p> <p>NOTE THIS IS AN UNCONTROLLED DOCUMENT ISSUED FOR INFORMATION PURPOSES ONLY. UNLESS THE CHECKED SECTIONS ARE SIGNED OR COMPLETED, FIGURED DIMENSIONS TAKE PRECEDENCE OVER SCALED. DO NOT SCALE REDUCED SIZE DRAWINGS. VERIFY DIMENSIONS PRIOR TO COMMENCING ANY WORKS OR FABRICATION. IF IN DOUBT - ASK.</p>	<p>VDM CONSULTING</p> <p>VDM Consulting (QLD) Pty Ltd ABN: 91 087 601 296</p>	<p>Sunshine Coast Level 1, 181 Brisbane Road PO Box 200 Mooloolaba QLD 4557 T: +61 7 5444 0400 F: +61 7 5444 0536 E: sunshinecoast@vdmgroup.com.au</p> <p>Fraser Coast Coral Coast Gladstone T: +61 7 4128 3955 T: +61 7 4152 6655 T: +61 7 4972 9522 F: +61 7 4124 1683 F: +61 7 4152 6633 F: +61 7 4972 9577</p>	<p>PROJECT: PROPOSED WAYFINDING SIGNAGE.</p> <p>FOR: SUNSHINE COAST REGIONAL COUNCIL.</p>	DATE: FEB 2011	SCALE AS SHOWN	A3
	Amendment	Date	By					DESIGNED: RTP	APPROVED: <i>Malcolm</i>	DRAWN: NJN
No.								SC110004	01.01	A

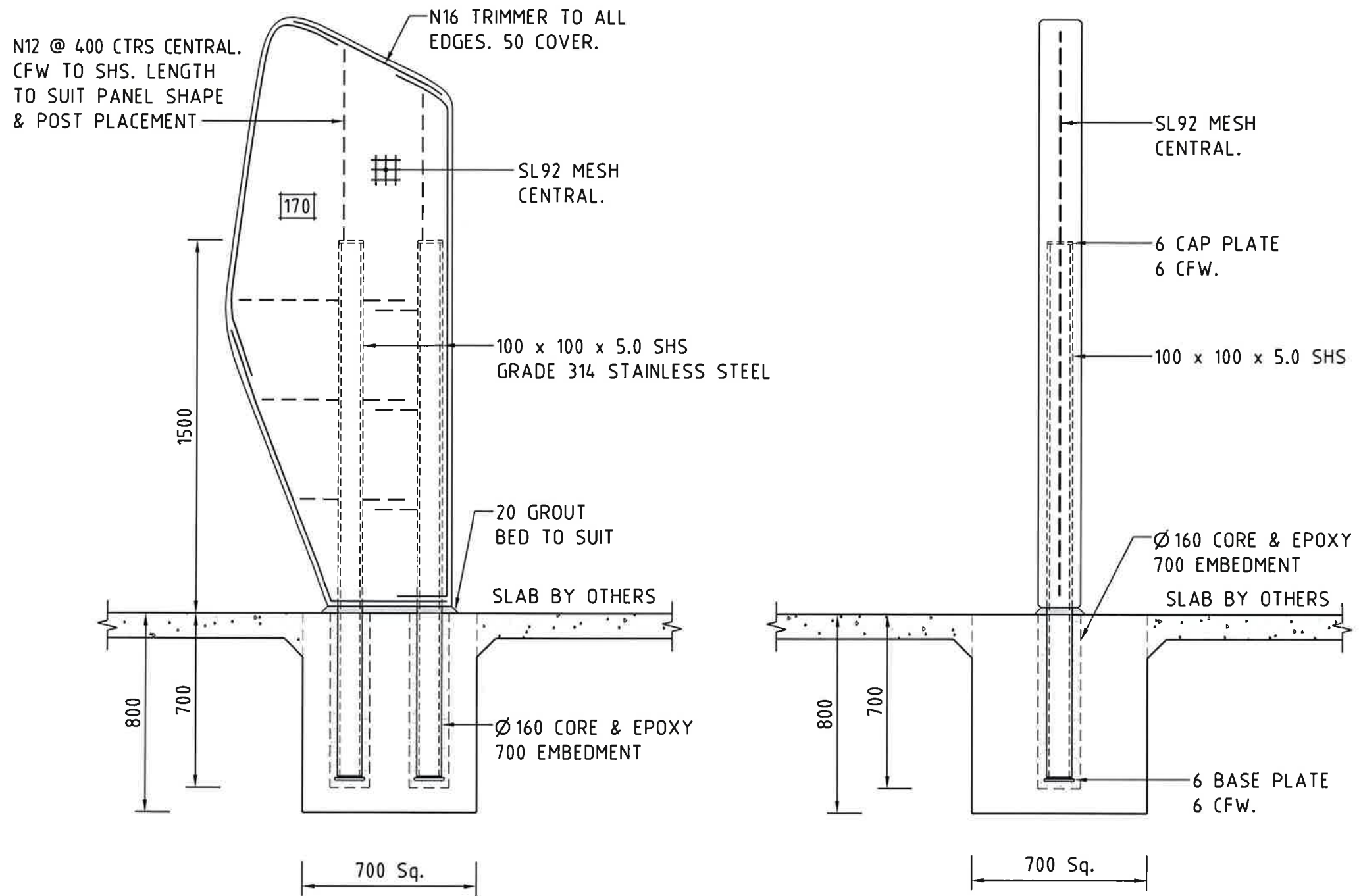

GENERAL NOTES:

1. ALL BEAMS TO HAVE N12 CORNER BARS (500 x 500) TO MATCH REINF. AS SPECIFIED. PROVIDE 2/N12 SPLICE BARS (600 MIN. LAP) AT ALL BEAM JUNCTIONS.
2. BASES OF ALL EXCAVATIONS TO BE FINISHED SOUND AND FREE OF ANY LOOSE MATERIAL PRIOR TO PLACEMENT OF CONCRETE.
3. TERMITE PROTECTION TO BE PROVIDED IN ACCORDANCE WITH THE BUILDING CODE OF AUSTRALIA AND OTHER RELEVANT CODES.
4. ALL FOOTINGS TO FOUND 300 INTO NATURAL SURFACE BY MEANS OF DIRECT BEARING. ALTERNATIVELY PROVIDE Ø350 M.C. BORED PIERS @ 1800crs TO FOUND 300 INTO NATURAL SURFACE.
5. IF LARGE TREES ARE REMOVED DURING SITE PREPARATION. THE VOIDS ARE TO BE EXCAVATED, BACKFILLED & COMPACTED WITH SUITABLE MATERIAL SIMILIAR TO THE EXCAVATED MATERIAL.

FOOTING SCHEDULE

FB1 700sq x 800d MC FOOTING

CONCRETE GRADES

FOOTINGS - N20 CONCRETE
TILT PANELS - N40 CONCRETE

TILT PANEL INFORMATION MAP 1:20 at A3

REFER TO ARCHITECTURAL SPECIFICATION FOR ALL SET OUT DIMENSIONS, FINISHINGS, FLASHINGS, WATERPROOFINGS, ETC.

FOR CONSTRUCTION

A	ISSUED FOR CONSTRUCTION	22.02.2011	SGT	<p>VDM CONSULTING</p> <p>Copyright THIS DRAWING IS COPYRIGHT AND THE PROPERTY OF VDM CONSULTING (QLD) PTY LTD. IT MUST NOT BE RETAINED, COPIED OR USED WITHOUT THE AUTHORITY OF VDM CONSULTING (QLD) PTY LTD.</p> <p>Disclaimer THIS DRAWING AND ITS CONTENTS ARE ELECTRONICALLY GENERATED ARE CONFIDENTIAL AND MAY ONLY BE USED FOR THE PURPOSE FOR WHICH THEY WERE INTENDED. VDM CONSULTING (QLD) PTY LTD WILL NOT ACCEPT RESPONSIBILITY FOR ANY CONSEQUENCES ARISING FROM THE USE OF THE DRAWING FOR OTHER THAN ITS INTENDED PURPOSE OR WHERE THE DRAWING HAS BEEN ALTERED, AMENDED OR CHANGED EITHER MANUALLY OR ELECTRONICALLY BY ANY THIRD PARTY.</p> <p>NOTE THIS IS AN UNCONTROLLED DOCUMENT ISSUED FOR INFORMATION PURPOSES ONLY. UNLESS THE CHECKED SECTIONS ARE SIGNED OR COMPLETED, FIGURED DIMENSIONS TAKE PRECEDENCE OVER SCALED. DO NOT SCALE REDUCED SIZE DRAWINGS. VERIFY DIMENSIONS PRIOR TO COMMENCING ANY WORKS OR FABRICATION. IF IN DOUBT - ASK.</p>	<p>Sunshine Coast Level 1, 181 Brisbane Road PO Box 200 Mooloolaba QLD 4557 T: +61 7 5444 0400 F: +61 7 5444 0536 E: sunshinecoast@vdmgroup.com.au</p> <p>Fraser Coast Coral Coast Gladstone T: +61 7 4128 3955 T: +61 7 4152 6655 T: +61 7 4972 9522 F: +61 7 4124 1683 F: +61 7 4152 6633 F: +61 7 4972 9577</p>	<p>PROJECT: PROPOSED WAYFINDING SIGNAGE.</p> <p>FOR: SUNSHINE COAST REGIONAL COUNCIL.</p>	DATE: FEB 2011	SCALE AS SHOWN	A3
	No.	Amendment	Date				By	DESIGNED: RTP	APPROVED: <i>Mark Ward</i>
							DRAWN: NJN		
							CHECKED: NDW	R.P.E.Q.	
							PROJECT	SET.SHEET	REV
							SC110004	01.02	A

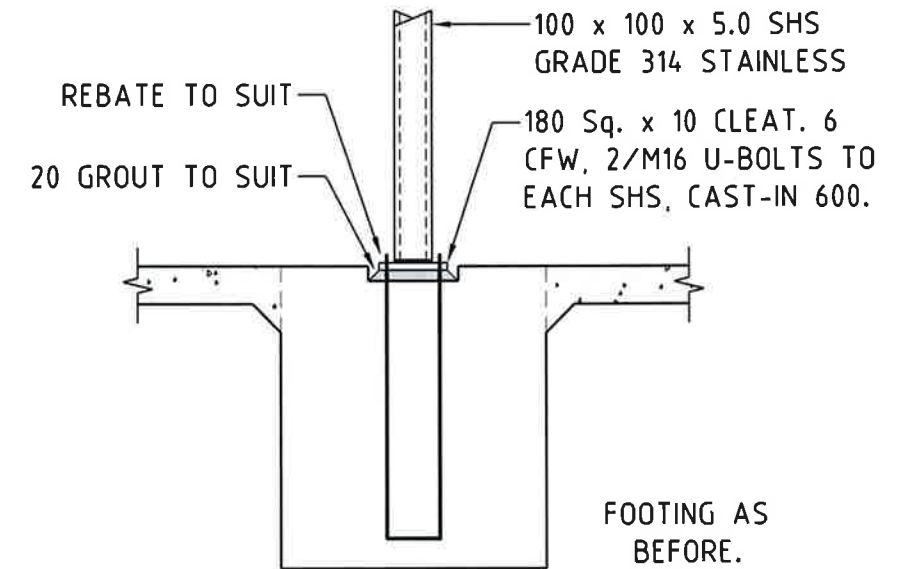
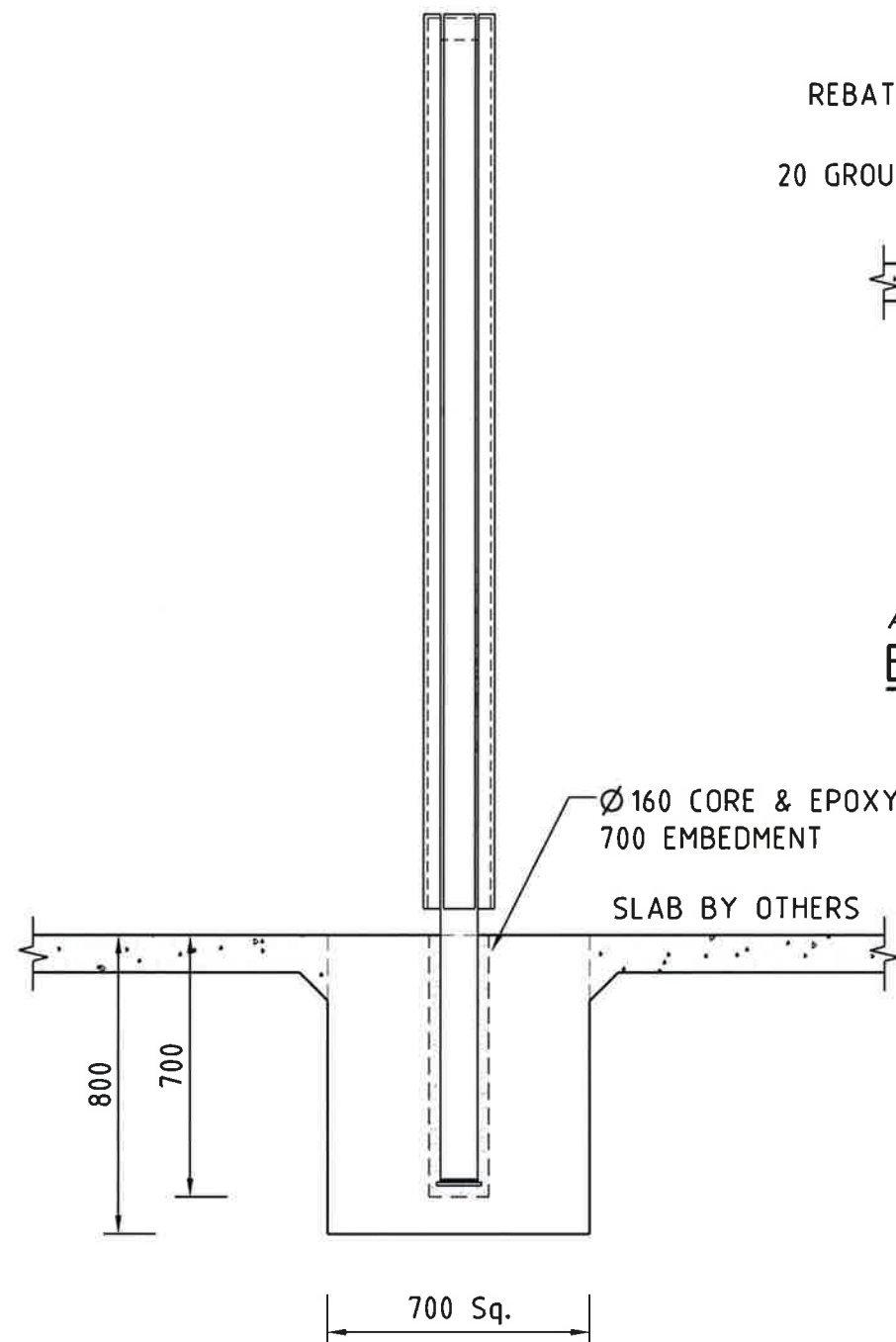
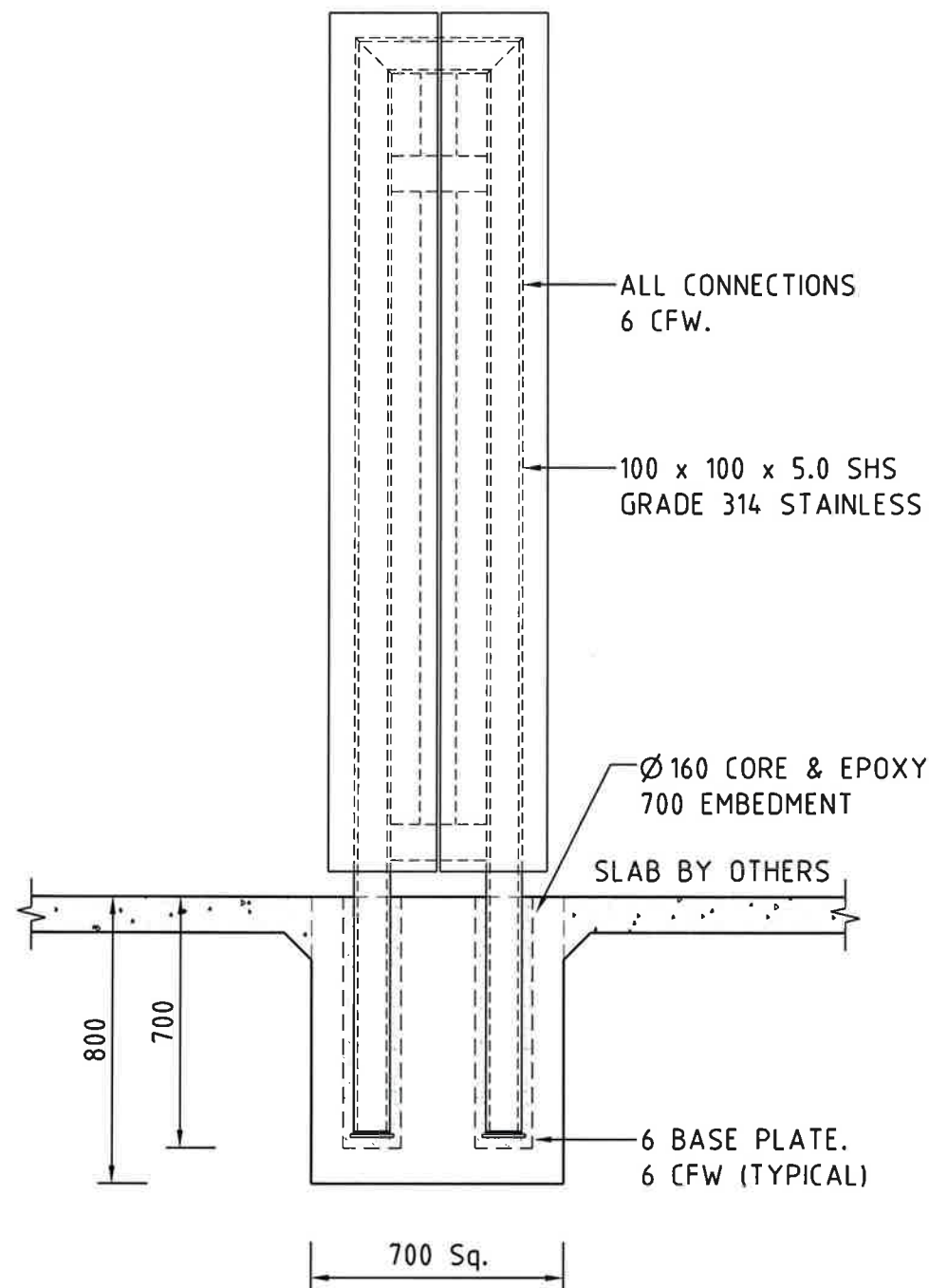

ALTERNATIVE
BASE PLATE DETAIL 1:20 at A3

TIMBER CLAD INFORMATION MAP 1:20 at A3

REFER TO ARCHITECTURAL SPECIFICATION FOR ALL SET OUT DIMENSIONS, FINISHINGS,
 FLASHINGS, WATERPROOFINGS, ETC.

FOR CONSTRUCTION

A	ISSUED FOR CONSTRUCTION	22.02.2011	SGT	<small>COPYRIGHT THIS DRAWING IS COPYRIGHT AND THE PROPERTY OF VDM CONSULTING (QLD) PTY LTD. IT MUST NOT BE RETAINED, COPIED OR USED WITHOUT THE AUTHORITY OF VDM CONSULTING (QLD) PTY LTD.</small> <small>DISCLAIMER THIS DRAWING AND ITS CONTENTS ARE ELECTRONICALLY GENERATED, ARE CONFIDENTIAL AND MAY ONLY BE USED FOR THE PURPOSE FOR WHICH THEY WERE INTENDED. VDM CONSULTING (QLD) PTY LTD WILL NOT ACCEPT RESPONSIBILITY FOR ANY CONSEQUENCES ARISING FROM THE USE OF THE DRAWING FOR OTHER THAN ITS INTENDED PURPOSE OR WHERE THE DRAWING HAS BEEN ALTERED, AMENDED OR CHANGED EITHER MANUALLY OR ELECTRONICALLY BY ANY THIRD PARTY.</small> <small>NOTE THIS IS AN UNCONTROLLED DOCUMENT ISSUED FOR INFORMATION PURPOSES ONLY. UNLESS THE CHECKED SECTIONS ARE SIGNED OR COMPLETED, FIGURED DIMENSIONS TAKE PRECEDENCE OVER SCALED. DO NOT SCALE REDUCED SIZE DRAWINGS. VERIFY DIMENSIONS PRIOR TO COMMENCING ANY WORKS OR FABRICATION. IF IN DOUBT - ASK.</small>		Sunshine Coast Level 1, 181 Brisbane Road PO Box 200 Mooloolaba QLD 4557 T: +61 7 5444 0400 F: +61 7 5444 0536 E: sunshinecoast@vdmgroup.com.au	PROJECT: PROPOSED WAYFINDING SIGNAGE.	DATE: FEB 2011	SCALE AS SHOWN	A3
	No.	Amendment	Date					By	 VDM Consulting (QLD) Pty Ltd ABN: 91 087 601 296	Fraser Coast Coral Coast Gladstone T: +61 7 4128 3955 T: +61 7 4152 6655 T: +61 7 4972 9522 F: +61 7 4124 1683 F: +61 7 4152 6633 F: +61 7 4972 9577

SC110004 01.03 A

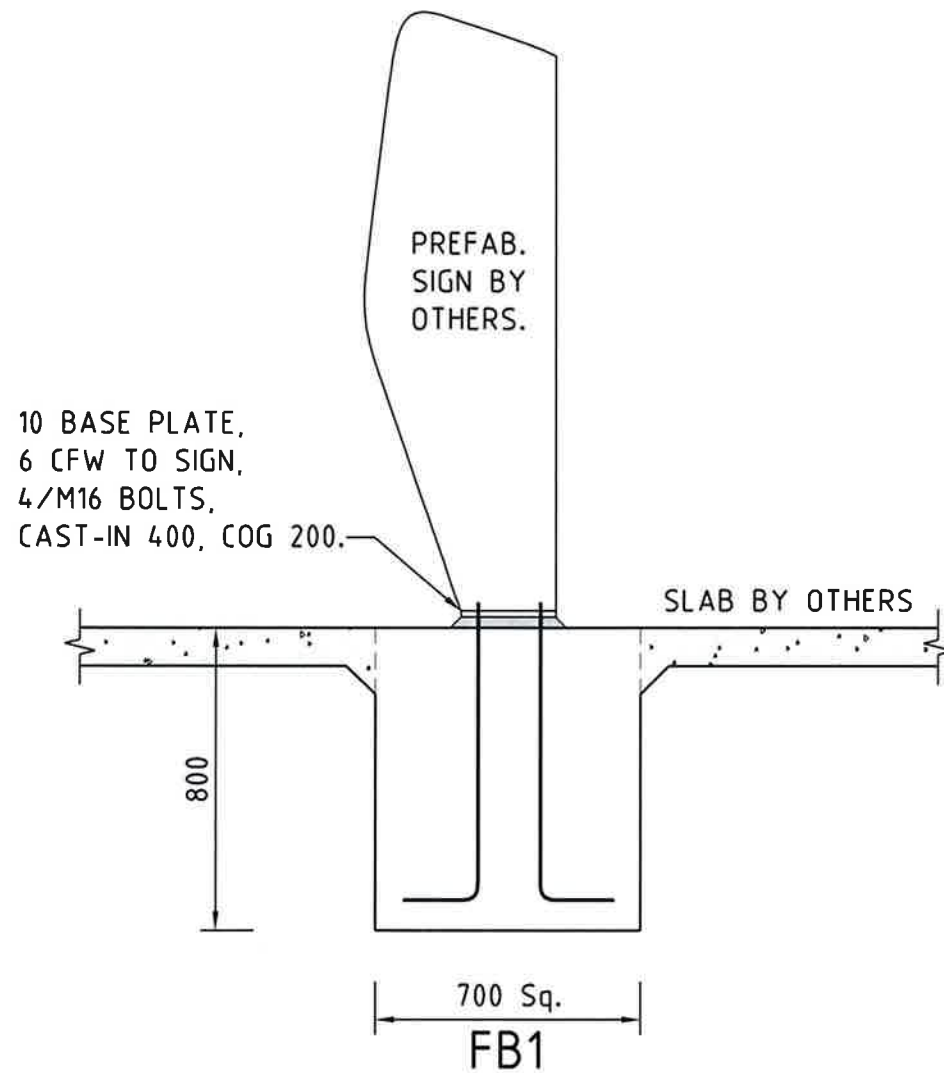

ALL EXTERNAL BOLTS,
NUTS/ WASHERS ETC. TO
BE STAINLESS STEEL
(UNLESS NOTED OTHERWISE)

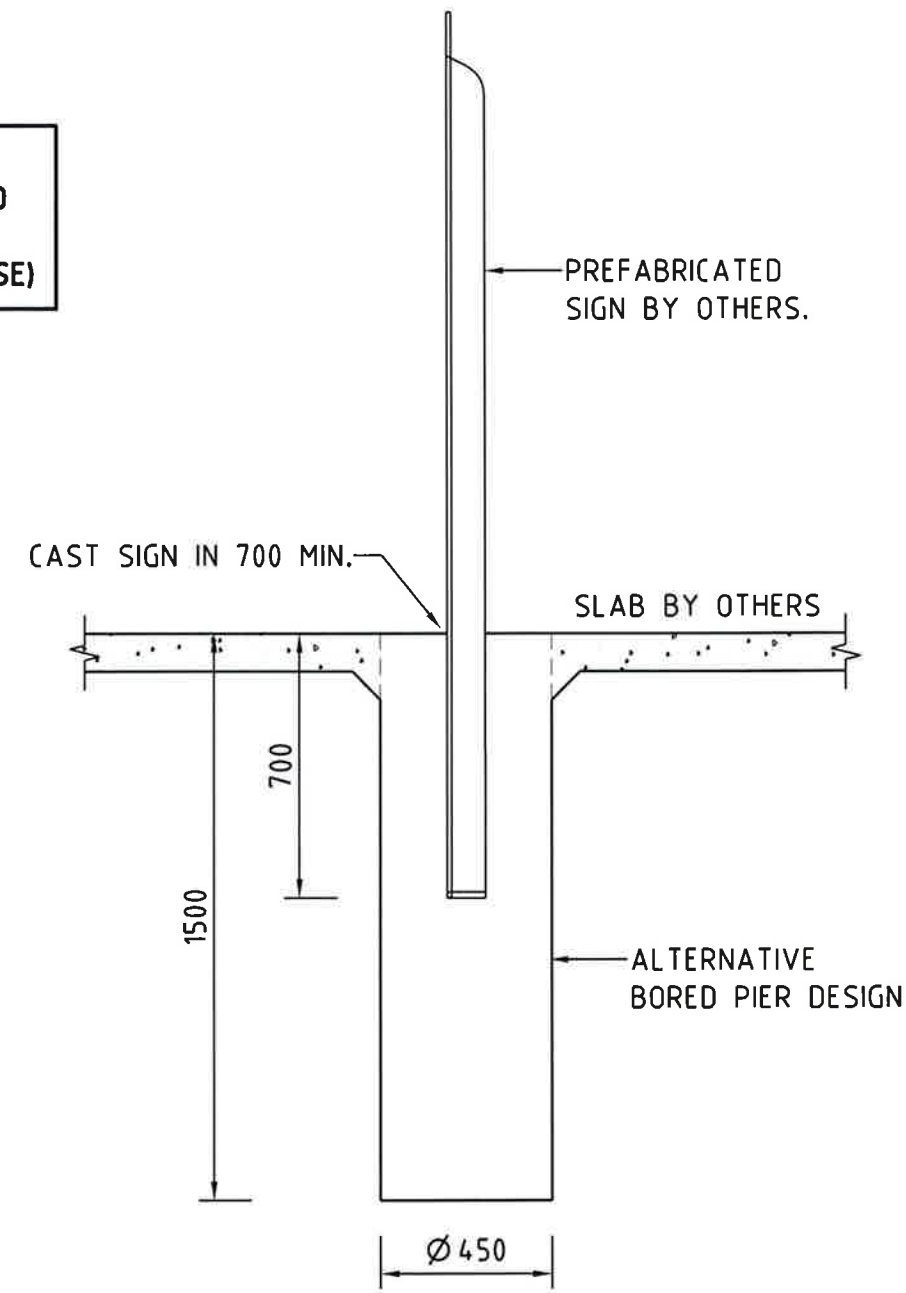

DIRECTIONAL BLADE SIGN 1:20 at A3

REFER TO ARCHITECTURAL SPECIFICATION FOR ALL SET OUT DIMENSIONS, FINISHINGS,
FLASHINGS, WATERPROOFINGS, ETC.

ALTERNATIVE FOOTING/FIXING DETAIL 1:20 at A3

FOR CONSTRUCTION

A	ISSUED FOR CONSTRUCTION	22.02.2011	SGT	<small>COPYRIGHT</small> THIS DRAWING IS COPYRIGHT AND THE PROPERTY OF VDM CONSULTING (QLD) PTY LTD. IT MUST NOT BE RETAINED, COPIED OR USED WITHOUT THE AUTHORITY OF VDM CONSULTING (QLD) PTY LTD. <small>DISCLAIMER</small> THIS DRAWING AND ITS CONTENTS ARE ELECTRONICALLY GENERATED, ARE CONFIDENTIAL AND MAY ONLY BE USED FOR THE PURPOSE FOR WHICH THEY WERE INTENDED. VDM CONSULTING (QLD) PTY LTD WILL NOT ACCEPT RESPONSIBILITY FOR ANY CONSEQUENCES ARISING FROM THE USE OF THE DRAWING FOR OTHER THAN ITS INTENDED PURPOSE OR WHERE THE DRAWING HAS BEEN ALTERED, AMENDED OR CHANGED EITHER MANUALLY OR ELECTRONICALLY BY ANY THIRD PARTY. <small>NOTE</small> THIS IS AN UNCONTROLLED DOCUMENT ISSUED FOR INFORMATION PURPOSES ONLY. UNLESS THE CHECKED SECTIONS ARE SIGNED OR COMPLETED, FIGURED DIMENSIONS TAKE PRECEDENCE OVER SCALED. DO NOT SCALE REDUCED SIZE DRAWINGS. VERIFY DIMENSIONS PRIOR TO COMMENCING ANY WORKS OR FABRICATION. IF IN DOUBT - ASK.	 VDM Consulting (QLD) Pty Ltd ABN: 91 087 601 296	Sunshine Coast Level 1, 181 Brisbane Road PO Box 200 Mooloolaba QLD 4557 T: +61 7 5444 0400 F: +61 7 5444 0536 E: sunshinecoast@vdmgroup.com.au Fraser Coast Coral Coast Gladstone T: +61 7 4128 3955 T: +61 7 4152 6655 T: +61 7 4972 9522 F: +61 7 4124 1683 F: +61 7 4152 6633 F: +61 7 4972 9577	PROJECT: PROPOSED WAYFINDING SIGNAGE. FOR: SUNSHINE COAST REGIONAL COUNCIL.	DATE: FEB 2011	SCALE AS SHOWN	A3
	Amendment	Date	By					DESIGNED: RTP	APPROVED:	DRAWN: NJN
No.								SC110004	01.04	A

APPENDIX C

Sunshine Coast Regional Council Wayfinding Strategy Report