

QUEENSLAND

Residential Design

g u i d e l i n e s



Queensland Department of
LOCAL GOVERNMENT & PLANNING
incorporating
RURAL COMMUNITIES



FOREWORD

The Queensland Residential Design Guidelines have been prepared to provide clear guidance for developing residential areas in Queensland. The guidelines have been produced as part of a program to implement the Australian Model Code for Residential Development (AMCORD) throughout Australia with funding assistance from the National Office of Local Government within the Commonwealth Department of the Environment, Sport and Territories.

The purpose of the guidelines is to have a document which is more practically suited to Queensland conditions than the current AMCORD. They are designed to promote a degree of consistency across local governments in their approach to residential development, and to respond to market demands by promoting flexibility and taking a performance-based approach to development assessment.

The Guidelines are targeted at designers and assessors of residential development, and apply to all residential types, up to and including three storeys in height (or three storeys over car parking). The Guidelines are exactly that – guidelines – and are not meant to be mandatory. It is up to individual local governments to determine whether they incorporate the document in total or in part in their planning schemes. Alternatively they may create their own guidelines using the principles within this document.

Consultation with local governments, peak industry and practitioner bodies and individuals was undertaken during the document's preparation, resulting in their support for the approach taken in the Guidelines. Use of the Guidelines and their performance-based approach to design and assessment is being promoted throughout Queensland to practitioners, the finance sector, education authorities, communities and consumers.

The document will be able to be referenced as a code under the Integrated Planning legislation, and we commend its use as a means of achieving more efficient and better quality urban development in Queensland.



(Mrs) Di McCauley MLA
Minister for Local Government
and Planning
Member for Callide



Warwick Smith, MP
Minister for Sport, Territories
and Local Government
Federal Member for Bass

ACKNOWLEDGMENTS

This booklet was developed by the Queensland Department of Local Government and Planning with funding assistance from the National Office of Local Government within the Commonwealth Department of Environment Sport and Territories.

It was developed in collaboration with the Local Government Association of Queensland, the Building Designers Association of Queensland, the Royal Australian Planning Institute (Queensland Division), the Association of Consulting Surveyors Queensland, the Urban Development Institute of Australia, the Housing Industry Association, the Institute of Municipal Engineering Australia (Queensland Division), the Queensland Master Builders Association and consultants Emily Schindeler of S and S Consultants Pty Ltd and Paul Eagles of Green Street Designs Pty Ltd.

Thanks are expressed to numerous other organisations and individuals who contributed in various ways through workshops held in Cairns, Townsville, Rockhampton and Brisbane.

TABLE OF CONTENTS

	SECTION PAGE NUMBERS
PART 1 SINGLE DETACHED HOUSING	1 – 37
PART 2 ATTACHED HOUSING	1 – 53
PART 3 INTEGRATED DEVELOPMENT	1 – 70
PART 4 SUBDIVISION	1 – 31

Queensland Residential Design Guidelines

ISBN 0 7242 7801 X

This work is copyright. It may be reproduced in whole or in part for study or training purposes, or by State, Territory and local government officers for work related purposes, subject to the inclusion of acknowledgment of the source and no commercial usage or sale. Reproduction for purposes other than those indicated above, requires the written permission from the Queensland Department of Local Government and Planning. Requests and inquiries concerning reproduction rights should be directed to Corporate Communications, Queensland Department of Local Government and Planning, PO Box 187, Albert Street, Brisbane 4002.

PREFACE

The Queensland Residential Design Guidelines manual is consistent with the aims of regional planning in Queensland, as clearly evident in the various projects being undertaken throughout the State. For example, the South East Queensland Regional Framework for Growth Management's (RFGM) objective on urban growth is "to establish a pattern of development for the year 2011, which utilises land efficiently in accordance with social and environmental objectives...". One of the RFGM's priority actions on residential development is to "increase average residential densities in new areas and by infill and redevelopment in existing areas, by the application of guidelines such as the Australian Model Code for Residential Development (AMCORD)." In addition, the Guidelines reinforce the need to set aside appropriate open spaces as essential elements in any land planning project.

The overall intent of this document is to illustrate best practice in urban residential design, widen the choice of housing and land development styles that are currently available, and enable more creative and efficient use of land.

The approach taken in developing the Guidelines has a number of features.

- 1 The document is derived from AMCORD, with variations more practically suited to priorities of Queensland practice. This is consistent with the intent of AMCORD, as it was produced as a resource document only. As such, it was intended for State and local governments to use it as a basis for their own more locally relevant guidelines, while retaining the integrity of the basic research.
- 2 The Queensland document has been designed as a basic working reference with a minimum of 'frills' - for example, explanatory text does not appear for each design element, and the reader may refer to AMCORD if they require further background.
- 3 The design element topics in total remain as per AMCORD, with the following exceptions. The element on 'Site Planning' is removed and a new element entitled 'Site Works' is added in relation to housing development. Part of the former element is relocated within the document as "Site Analysis" requirements, while the latter is included to further ensure minimal impact on adjacent land. In addition, 'Integrated Movement Networks', 'Pedestrian and Cyclist Facilities' and 'Public Transport', have been removed. This was on the basis that either the principles were considered to be sufficiently covered in other sections of the document, or that local governments would not have the ability to directly address some of the issues.
- 4 Specific references to housing density levels deemed as acceptable, are not included in the document. This is on the basis that, in the Queensland context, such decisions need to have already been taken, either during Planning Scheme, Strategic Plan or other Local Control Plan preparation, or when land use allocation decisions were made.

The Guidelines, while advisory in nature, have been the result of both industry and local government consultation. As a result, it is expected any variations in their proposed usage will require adequate justification.

QUEENSLAND RESIDENTIAL
DESIGN GUIDELINES

Single Detached

h o u s i n g

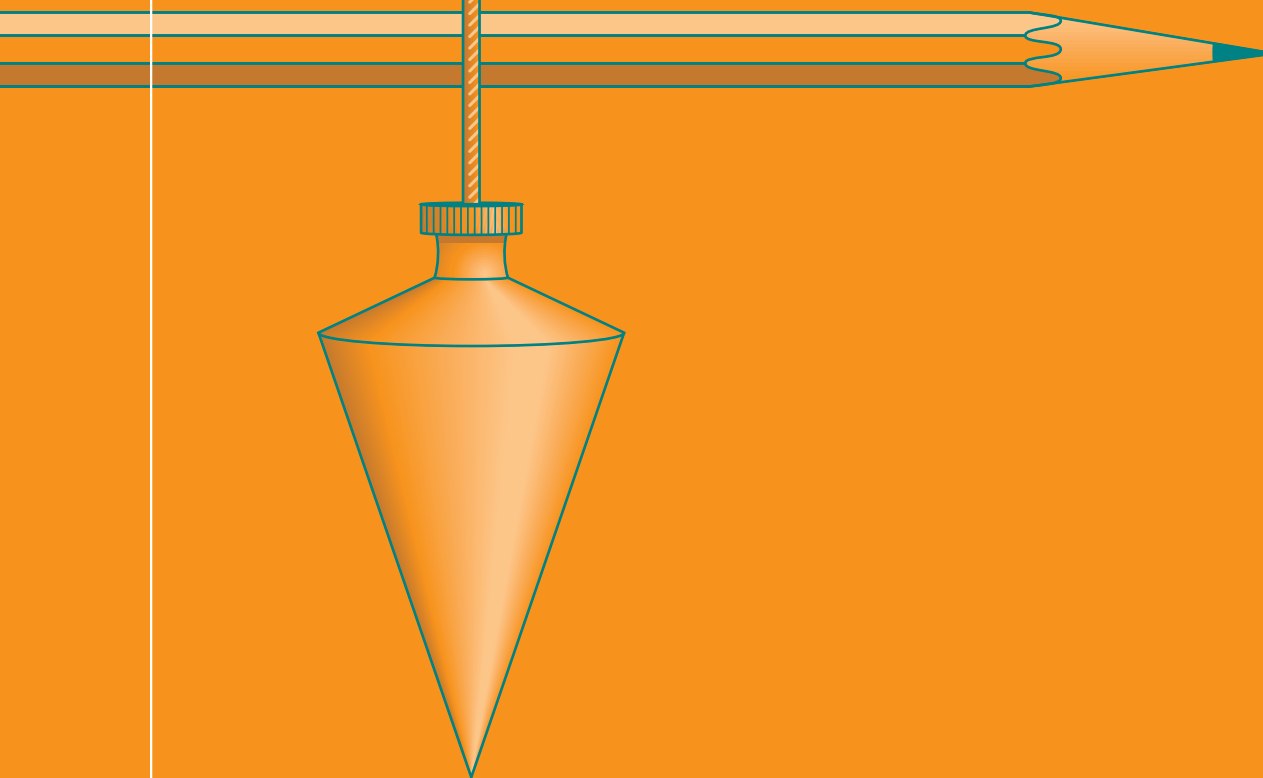

TABLE OF CONTENTS

Part 1 – Single Detached Housing

1.0	INTRODUCTION	1
1.1	APPLICATION OF DESIGN GUIDELINES	2
1.2	THE PERFORMANCE APPROACH	2
1.3	SITE ANALYSIS	3
1.4	DESIGN ELEMENTS	5
A GENERAL		
A1	Street Setbacks	5
A2	Building Envelope and Siting	7
A3	Storm Drainage	9
A4	On-site Carparking	10
A5	Private Open Space	11
A6	Site Works	12
B SITE SPECIFIC		
B1	Streetscape and Landscape	14
B2	Building Appearance and Neighbourhood Character	16
B3	Fences and Walls	18
B4	Bushfire Protection	20
	DEFINITIONS	21
	REFERENCES	23
APPENDIX		
C ADVISORY DESIGN ELEMENTS		
C1	Safety and Security	27
C2	Design for Climate	28
C3	Housing on Traffic Routes	33
C4	Privacy	36

1.0 Introduction

The Queensland Residential Design Guidelines have been produced for use by planners, designers, local government development control officers, builders, and developers involved in housing and residential development in Queensland.

The Guidelines are derived from the provisions of the Australian Model Code for Residential Development – A National Resource Document (AMCORD 1995), with modifications to suit Queensland conditions.

The Guidelines have four sections:

- 1 Single Detached Housing – for planning, design, and development of detached houses.
- 2 Attached Housing – for planning, design, and development of all forms, types, and arrangements of attached housing up to 3 storeys in height or 3 storeys over carparking.
- 3 Integrated Development – for integrated planning, design, and development of projects comprising 2 or more houses (includes residential components of mixed-use projects).
- 4 Subdivision – for planning, design and development of land subdivision for residential purposes, prior to housing construction.

Each section:

- comprises design elements presented using a performance-based approach (including intent, performance criteria, and a range of acceptable solutions suitable for Queensland).
- includes only those design elements of relevance to the particular type of residential development under consideration.
- references to related publications such as Queensland Streets and the Queensland Urban Drainage Manual.

Queensland Streets (IMEAQ 1996) provides the basis for a uniform standard of residential streetworks design, with detailed design criteria in accordance with AMCORD principles.

The Queensland Urban Drainage Manual (DPI et al, 1993) as well as considering environmental and legal aspects, provides planning guidelines and design processes and methods for urban stormwater drainage works in Queensland.

Each section has been prepared acknowledging that:

- certain design elements are essential to be complied with to achieve a satisfactory design solution;
- some design elements may only apply to certain parts of a local government area or may only apply to specific development applications; and
- other design elements exist which will result in a more highly sophisticated level of performance and have been included for their education role.

This has been achieved by the following organisation of the design elements:

General

Compliance with these elements is required to achieve an acceptable level of performance in planning, design, and development of residential projects.

Site Specific

Compliance with these elements is only required in special circumstances, where sufficient community interest warrants detailed consideration of them and/or a sophisticated residential planning, design, and development outcome is desired. These elements would usually be specified in specialised documents produced through community consultation, such as in conditions of rezoning and/or town planning consent, and/or provisions of a Development Control Plan.

Alternatively, developers might wish to voluntarily comply with these elements to dispel perceived community concerns.

Advisory

Advisory design elements have also been included as an appendix. Compliance with these design elements is not required to achieve compliance with the Residential Design Guidelines. They have been included as they are considered to be 'desirable' design elements from the perspective of creating good design outcomes. However, due to the subjective nature of the design elements and the difficulty in specifying acceptable solutions, it is not considered appropriate that these design elements be required to be complied with to achieve an approval. Consequently, the decision to apply these design elements is to remain with the designer, rather than the approving authority.

1.1 Application of Design Guidelines

In Queensland, the majority of detached housing applications are assessed for compliance against the Standard Building Law which incorporates the Building Code of Australia. The Single Detached Housing Guidelines have not been formulated, and are inappropriate, to be applied to these types of applications.

Rather, the Single Detached Housing Guidelines are appropriate where the planning scheme requires planning approval for detached housing due to specific circumstances such as:

- for small allotments (eg: less than 450m²) and no previously approved Plan of Development exists for these lots;
- lots in drainage problem areas; and
- areas of heritage value, or of a particularly desirable neighbourhood character.

Where a plan of development has been approved as part of an earlier development application, these guidelines will not apply. In this instance, the design criteria detailed in the plan of development will take precedence; unless stated otherwise in the plan of development.

Applications for duplexes are not covered by these guidelines as they come within the scope of the Attached Housing Guidelines.

The Single Detached Housing Guidelines apply irrespective of lot tenure (eg: community title or torrens title).

In the circumstance of community title development, the site boundary shall be taken as the community title lot boundary.

If the development application is for a number of detached houses, the Integrated Development Guidelines apply.

1.2 The Performance Approach

The Queensland Residential Design Guidelines adopts a performance-based system of control. Instead of specifying prescriptive standards, it focuses on matters to be addressed (called Performance Criteria) in order to achieve a desired outcome (called Intent).

Such a performance-based system centred on objectives and desired outcomes, offers an opportunity for diversity and choice, and provides flexibility to respond to market

needs and preferences, and changes in approaches and technology.

Performance-based regulation is enhanced if examples of ways in which the desired result can be achieved are indicated. Acceptable Solutions are provided as examples of what is considered acceptable, while not precluding other options.

The Acceptable Solutions illustrate ONE WAY only of meeting the associated Performance Criteria. The acceptability of other solutions would need to be demonstrated. This may be achieved with reference to built examples, plans and/or illustrations representing contemporary best practice in residential planning, design and development.

Each Design Element has a consistent format (refer figure 1). A concise statement of intent is at the top of the page (1). The left column sets the Performance Criteria (2) and the right column Acceptable Solutions (3) relates to the relevant Performance Criteria.

The Guidelines do not repeat the explanatory and background material included in AMCORD for each Design Element. This material however, should be referenced where alternative solutions are proposed, or where clarity is required in relation to the source and/or intention of the Performance Criteria.

1 Intent

The Intent outlines the aim of the Design Element and reflects identified planning and policy requirements.

In complying with the Intent, an applicant must conform to all relevant Performance Criteria. Where Acceptable Solutions have been documented to cover specific Performance Criteria, designers can use these in satisfaction of the Performance Criteria.

2 Performance Criteria

Performance Criteria are general statements of the means of achieving the Intent. They are not meant to be limiting in nature. Instead, they provide designers and developers with an opportunity to develop a variety of design responses.

Not all Performance Criteria will be applicable to every development. In submitting a proposal for approval, the designer and developer must indicate those criteria not relevant to their particular development.

1.2 The Performance Approach (continued)

In other circumstances, some performance criteria may be found to conflict with other performance criteria. In these instances, “trade-offs” may need to be considered as part of the design and approval process in arriving at an acceptable solution.

3 Acceptable Solutions

Acceptable Solutions are provided as examples of what may satisfy Performance Criteria. They should not be interpreted as an alternative prescriptive form of regulation, nor should they preclude other solutions.

Acceptable solutions may not be provided for all Performance Criteria. In those instances, solutions specific for each circumstance will need to be developed by the designer.

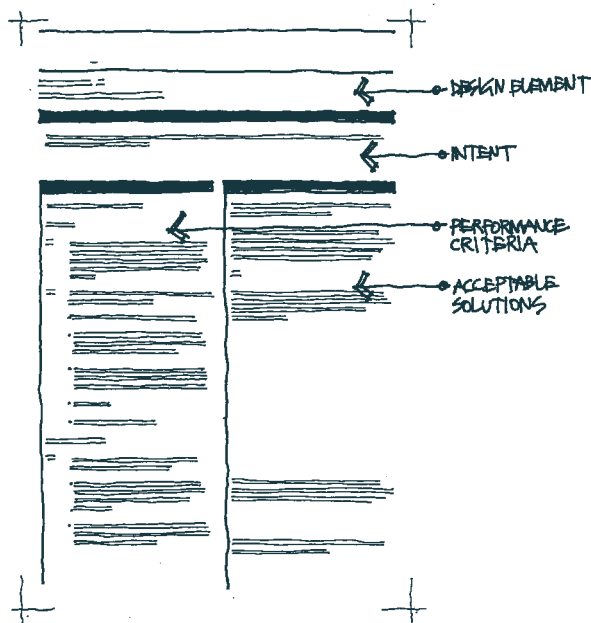

Figure 1: The layout of a typical page for a Design Element

1.3 Site Analysis

A detailed and comprehensive site analysis is the foundation of any good design and should be carried out if the intent of these guidelines is to be achieved.

Specifically, the objective of the site analysis is to ensure that a coherent site layout and design is achieved which:

- identifies the constraints of the site;
- highlights the site’s opportunities; and

- shows the important aspects of the surrounding environment.

The site analysis plan highlights a number of aspects which can be readily otherwise overlooked, namely:

- the need for retaining walls and the impact on adjoining properties’ amenity;
- redirection of overland flow paths; and
- clashes of services and building works.

The submission of a site analysis plan will assist in the development assessment process and is needed should more innovative design solutions be proposed. The site analysis plan should include at least:

- existing and proposed contours;
- where practicable, identification of previously filled areas;
- drainage paths entering the site;
- all existing services and easements on the site or adjoining roadway;
- existing buildings, fences, vegetation or other natural site features of identified conservation or heritage value.

In addition, other matters which may be relevant depending on the specific circumstance include:

- orientation, significant noise sources and micro-climate (eg: keeping potential for breezes);
- views to and from the site;
- prevailing winds; and
- built form and character of adjacent and nearby development.

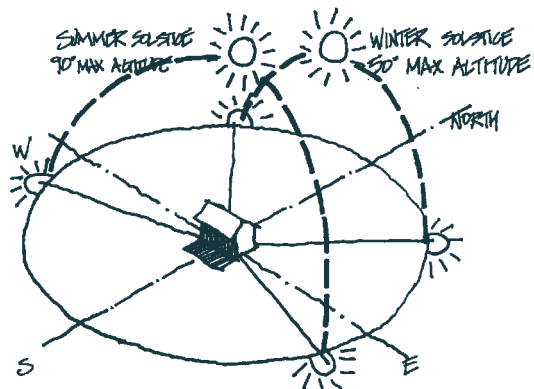

Figure 2: Solar path diagram

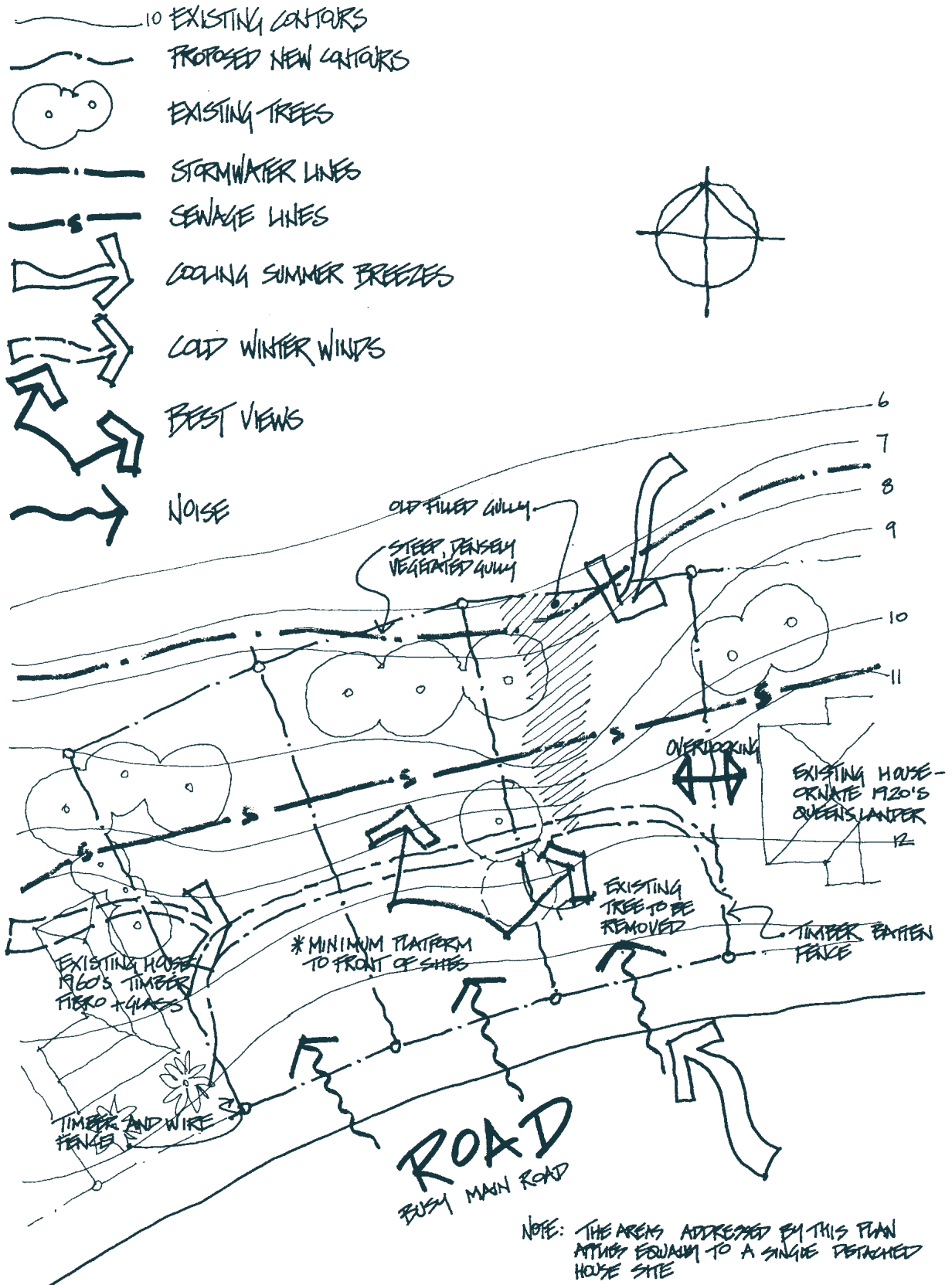

Figure 3: Typical site analysis plan

ELEMENT A1

Street Setbacks

INTENT

To setback dwellings and garages/carports from the street to provide adequate space for landscape or open space, visual and acoustic privacy and vehicle parking.

PERFORMANCE CRITERIA

The intent may be achieved where:

- P1** The setback of dwellings makes efficient use of the site, provides amenity for residents and allows space for the required vehicle parking.

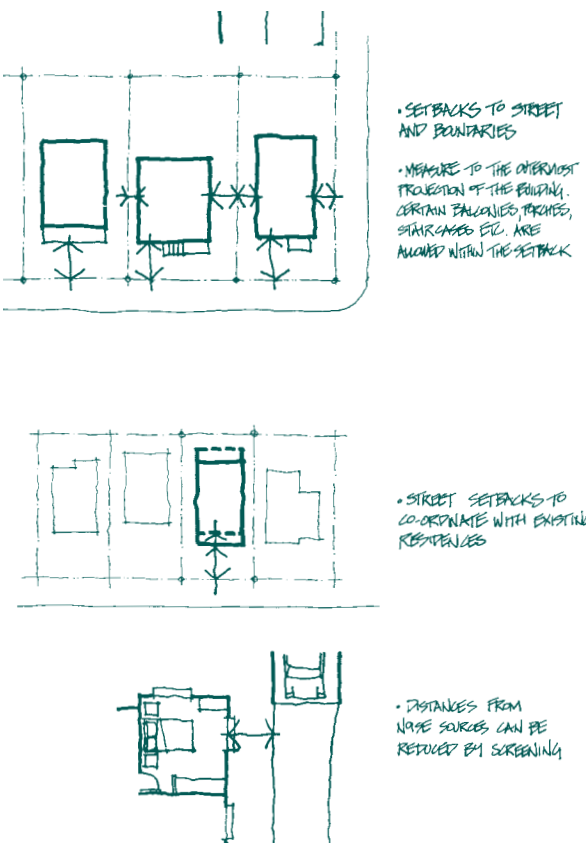

Figure 4: Street / noise source setbacks

ACCEPTABLE SOLUTIONS

The Acceptable Solutions illustrate ONE WAY of meeting the associated Performance Criteria.

- A1.1** A Streetscape Concept Plan and/or Landscape Plan is submitted that demonstrates how the Performance Criteria is met.

OR

- A1.2** In areas being urbanised or newly-developed areas, setbacks (inclusive of any verandah, porch etc) from the street boundary should be as follows:

TABLE 1: Street setbacks in new areas¹

Street type	Minimum frontage setback (m)	Minimum side setback to corner street (m)
Access Place and Access Street	3.0	1.0
Collector Street	4.0	2.0

¹ The setback may be averaged, providing no part of the building is setback less than 2m.

OR

- A1.3** In established areas where the setback of an adjacent building is greater than 3m, the minimum street setback of infill development is to be the lesser of:

- the setback specified in the Standard Building Law; and
- the same distance as one or the other of the adjoining buildings, provided the difference between the setbacks of the two adjoining buildings is less than or equal to 2m; or
- the average of the setbacks of the adjoining dwellings, if the difference between the setbacks of the adjoining buildings is greater than 2m.

ELEMENT A 1

Street Setbacks continued

PERFORMANCE CRITERIA

ACCEPTABLE SOLUTIONS

- A1.4** In established areas where the setbacks of adjacent buildings are 0–3m, infill development is to be setback the same distance as one or the other of the adjoining dwellings.
- A1.5** Setback of buildings in significant urban conservation and heritage streetscapes shall generally match with that of adjacent development unless an alternative policy has been developed for that street.
- A1.6** In community title developments, walls of dwellings incorporating a habitable room to be setback a minimum of 1.5m from shared driveways, communal streets and visitor carparks. This setback may be reduced if suitable privacy screening and/or acoustic treatment to the dwelling walls is provided.
- A1.7** Single garages/carports associated with dwellings for which more than one on-site parking space is required are to be setback from the public street frontage a minimum of 5.5m if tandem parking is proposed.
- A1.8** Double garages/carports are setback from a corner or secondary street frontage to not less than half the setback to the street of any existing adjacent dwelling that faces the secondary street, provided that the setback is not less than that of the associated dwelling.

ELEMENT A 2

Building Envelope and Siting

INTENT

To enable flexibility in dwelling siting while protecting reasonable neighbour amenity expectations, maintaining appropriate residential character and visual bulk, and providing adequate daylight to dwellings and sunlight to private open space.

PERFORMANCE CRITERIA

Building Envelope Setbacks

- P1** Setbacks are progressively increased as wall height increases to reduce bulk and overshadowing while maintaining adequate daylight and sunlight.
- P2** Dwelling siting and height is related to land form.
- P3** Building bulk is generally distributed to reduce impact on neighbours and on the public street.
- P4** Dwelling heights are similar to those in the public streetscape, with taller buildings sited so as to minimise adverse impacts on neighbours and on the streetscape.
- P5** Dwelling forms enable a sharing of any longer views with neighbours.
- P6** Building to the boundary maximises privacy for neighbouring dwellings and their private open space.

ACCEPTABLE SOLUTIONS

The Acceptable Solutions illustrate ONE WAY of meeting the associated Performance Criteria.

Building Envelope and Setbacks

(in partial satisfaction of P1 to P5)

- A1.1** Where walls are not built to the boundary, side and rear setbacks shall comply with the Standard Building Law – Part 9.

ELEMENT A 2

Building Envelope and Siting continued

PERFORMANCE CRITERIA

P7 Boundary walls are limited in length and height, to minimise the impact on neighbours.

P8 Buildings are sited and designed to provide adequate daylight to habitable rooms.

ACCEPTABLE SOLUTIONS

A7.1 Walls built to side boundaries have:

- an average height of 3.0m
- a maximum height of 3.5m, unless they;
 - abut a higher existing or simultaneously constructed wall;
 - are in accord with an approved building envelope plan;
 - abut a side or rear lane (in which case the maximum height shall be 5.5m).

AND

A7.2 Where there are no existing boundary walls, the maximum boundary wall length is 15 metres.

OR

A7.3 The length of new boundary walls matches the length of existing boundary walls.

OR

A7.4 In areas where it has been determined to provide for an increase in development built to boundaries, the length of new boundary walls is limited to 50% of the length of the adjacent side boundary:

OR

A7.5 Where slope, retaining walls, fences and/or dwelling design would result in the effective height of a boundary wall being less than 2m on the adjacent property boundary, the new boundary wall can extend the full length of the side or rear boundary less any front boundary setback distance.

A8.1 Habitable rooms in dwellings have windows in compliance with the BCA sufficient to meet light requirements.

ELEMENT A 3

Storm Drainage

INTENT

To provide storm drainage systems which in terms of initial cost and maintenance, adequately protect the dwelling at an acceptable level of risk and in a cost-effective manner, and which contribute positively to environmental enhancement of catchment areas.

PERFORMANCE CRITERIA

The intent may be achieved where:

Roof Drainage

- P1** The roof drainage system has the capacity to control stormwater flows under normal operating conditions for the relevant design storm:
- which prevents the flow of stormwater from the guttering into the dwelling;
 - which does not concentrate or re-direct stormwater onto adjoining properties.
- P2** Design of the roof and site drainage system is such that it can be economically maintained with a reduced risk of blockages.

Site Drainage

- P3** The site drainage system has the capacity to control surface stormwater flows from the site and any excess flows from upstream properties to prevent stormwater flows from entering the dwelling in the design event.
- P4** The ground-floor level of the dwelling is located above the site surface level to an extent which prevents entry of stormwater flows into the dwelling in accordance with an acceptable level of risk.
- P5** The site drainage system minimises undesirable ponding for a prolonged period.
- P6** Design of the site drainage system provides for on-site infiltration if soil conditions are suitable.
- P7** Adequate provision is made for measures during construction to ensure that the land form is stabilised and erosion is controlled.

ACCEPTABLE SOLUTIONS

The Acceptable Solutions illustrate ONE WAY of meeting the associated Performance Criteria.

- A1** The roof drainage system is designed for a rainfall intensity derived for the area in which the design is proposed based on ARI = 20 years, 5 minutes duration.
- A2** Leaf guards fitted to guttering at downpipes. Clean out points provided on underground pipe systems.
- A3.1** Where the topography of the site makes it necessary to discharge stormwater run-off to the rear of the site, the run-off from all directly connected impervious areas (roof and paved areas) shall be to an inter-allotment drainage system (to the requirements of QUDM);
- OR
- A3.2** Where an inter-allotment drainage system is not available, discharge of storm run-off is to an on-site detention or dispersal system.
- A3.3** The site slopes away from the dwelling (50mm at 1000mm from dwelling).
- A4** Compliance with the BCA requirements for minimum floor heights.
- A5** Provide for no area to pond to a depth greater than 50mm within one hour following rainfall.
- A6** If soil conditions are suitable, soakage chamber installed within property with overflow via inter-allotment drainage system.
- A7** Site erosion prevention details are provided as per industry code of practice.

ELEMENT A 4

On-site Carparking

INTENT

To ensure adequate provision of secure and accessible on-site parking for residents and visitors.

PERFORMANCE CRITERIA

The intent may be achieved where:

- P1** Carparking is provided according to projected needs which are determined by:
- availability of public transport;
 - availability of on-street carparking;
 - carparking requirements of people of differing socio-economic status, age, cultural background and differing stages of family life cycle.

ACCEPTABLE SOLUTIONS

The Acceptable Solutions illustrate ONE WAY of meeting the associated Performance Criteria.

- A1.1** Dwellings on separate lots are provided with two on-site parking spaces, one of which is covered (the second space can be in tandem).

Note: Development plans may identify areas in which a lesser provision may be appropriate, based on for example housing density, accessibility to public transport and employment areas.

ELEMENT A 5

Private Open Space

INTENT

To ensure that the private open space provided for dwellings is clearly defined, usable and meets user requirements for privacy, access, outdoor activities and landscaping.

PERFORMANCE CRITERIA

The intent may be achieved where:

- P1** Private open space is clearly defined for private use.
- P2** Private open space areas are of dimensions to suit the projected requirements of the dwelling occupants, and to accommodate some outdoor recreational needs as well as providing space for service functions.
- P3** Part of the private open space is capable of serving as an extension of the dwelling for relaxation, dining, entertainment, recreation and children's play, and is accessible from a main living area of the dwelling.

ACCEPTABLE SOLUTIONS

The Acceptable Solutions illustrate ONE WAY of meeting the associated Performance Criteria.

- A1.1** For dwellings with a site area of 450m² or more, private open space for the dwelling comprises:
 - one part with an area of 25m² with a minimum dimension of 4m and directly accessible from a living area of the dwelling;
 - a maximum gradient of 1 in 10;
 - screening provided where necessary to ensure privacy to users of the open space.

OR

- A1.2** For dwellings with a site area less than 450m² private open space for the dwelling comprises:
 - one part with an area of 16m² with a minimum dimension of 4m and directly accessible from a living area of the dwelling;
 - a maximum gradient of 1 in 10;
 - screening provided where necessary to ensure privacy to users of the open space.

Note: A balcony or deck may be utilized as private open space areas where site gradients are excessive.



Figure 5: Small lot private open space

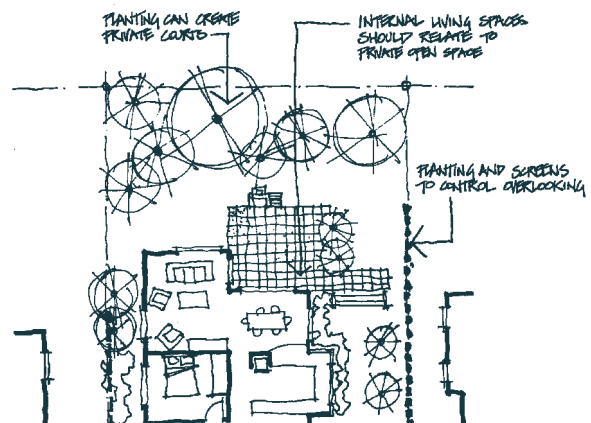

Figure 6: Private open space on larger lots

ELEMENT A6

Site Works

INTENT

To ensure the site works for dwellings do not adversely impact on adjoining properties, and are consistent with the design intent for the site.

PERFORMANCE CRITERIA

The intent may be achieved where:

- P1** Construction earthworks, particularly pad construction:
 - does not undermine, or result in earth spillage onto, adjoining properties;
 - does not redirect or concentrate stormwater flows onto adjoining properties;
 - makes allowances for utility services crossing or servicing the site;
 - makes allowances for future landscaping works to ensure satisfactory performance of the site storm drainage system.
- P2** The site works are undertaken so that the tracking of earth and other materials onto the public road way during the construction of the earthworks or the dwelling is minimised.
- P3** The site works are undertaken in such a manner as to ensure that there is no detriment by way of erosion, earth slippage or other hazard to adjoining properties during construction or in the event of building construction delay.

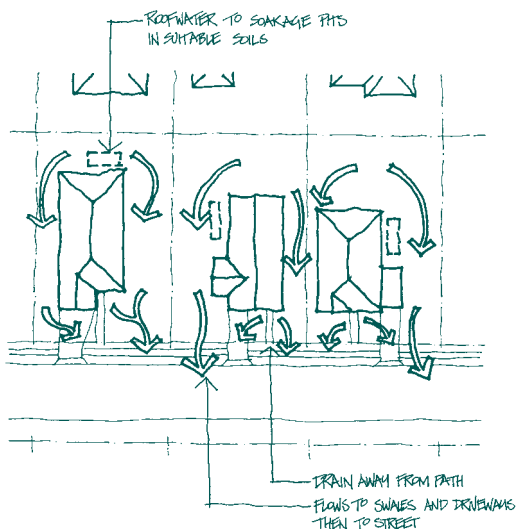

Figure 7: Site drainage methods

ACCEPTABLE SOLUTIONS

The Acceptable Solutions illustrate ONE WAY of meeting the associated Performance Criteria.

(in partial satisfaction of P1 to P3)

- A1** The submission of a Site Works Plan (or inclusion on the dwelling Site Plan) which demonstrates how the Performance Criteria are met showing:
 - details of all cut and fill showing finished levels, and proposed methods of retaining cut and fill material;
 - site drainage paths after earthworks and allowance for landscaping; and
 - location of all services and their levels in relation to finished earthworks levels.

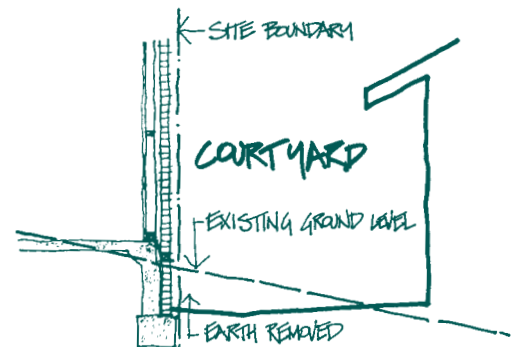

Figure 8: Desirable built to boundary detail
Low side of lot

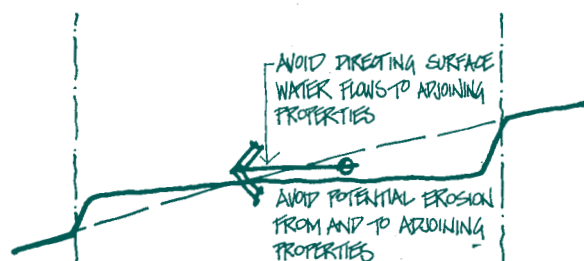





Figure 9: Earthworks site section

ELEMENT A6

Site Works *continued*

-  EXISTING STORMWATER DRAIN
-  EXISTING SEWERAGE
-  SURFACE WATER FLOWS
-  EXISTING CONTOURS

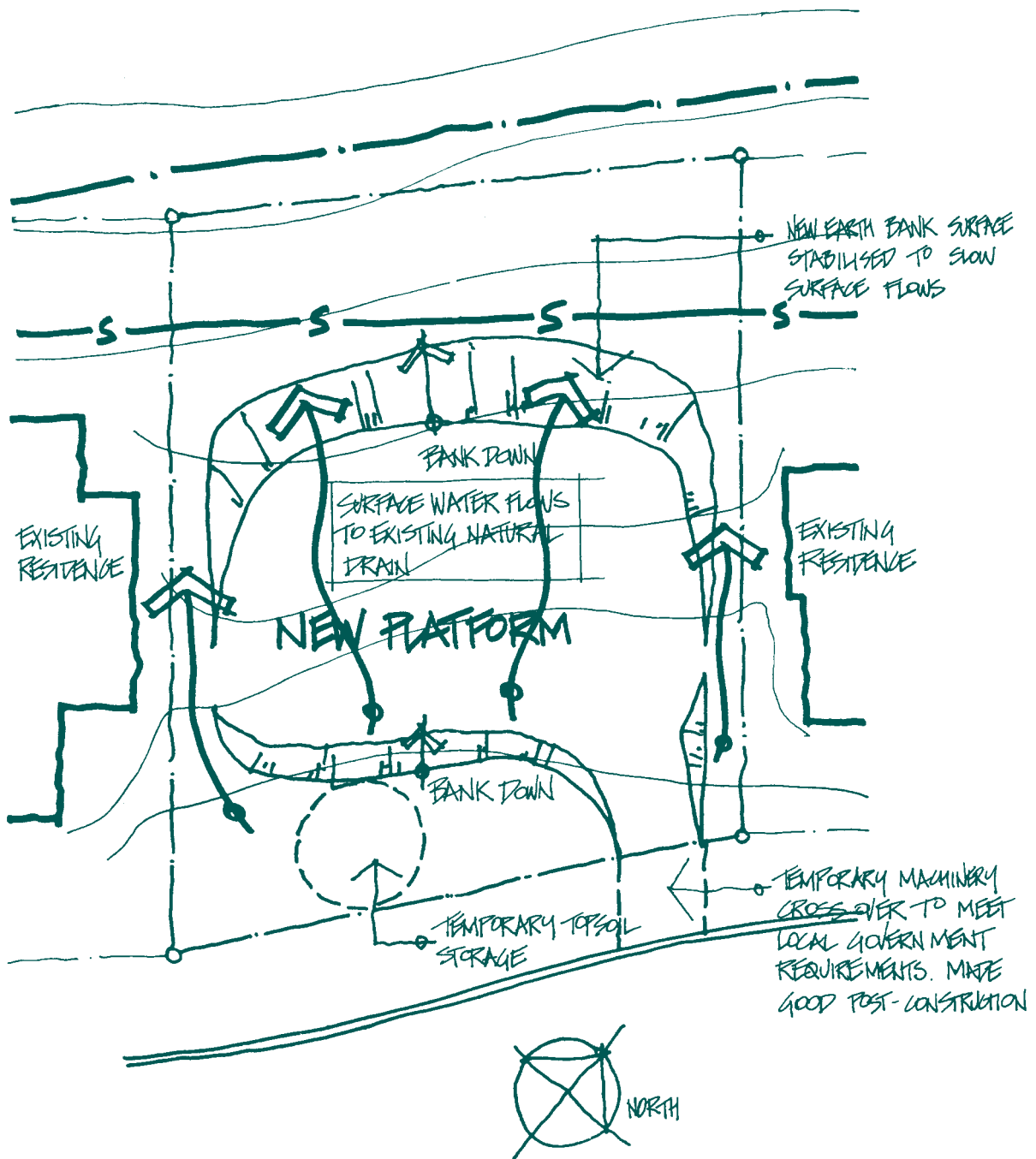

Figure 10: Typical site works plan

ELEMENT B1

Streetscape and Landscape

INTENT

To provide attractive streetscapes that reinforce the functions of a street, enhance the amenity of buildings, and are sensitive to the built form, landscape and environmental conditions of the locality.

PERFORMANCE CRITERIA

The intent may be achieved where:

P1 The street, building and landscape design achieves:

- the creation of residential environments with clear character and identity;
- respect for identified existing streetscapes in established areas;
- appropriate streetscapes in areas where desired future urban character has been defined;
- use of such features of the site as views, vistas, existing vegetation and landmarks.

ACCEPTABLE SOLUTIONS

The Acceptable Solutions illustrate ONE WAY of meeting the associated Performance Criteria:

A1.1 A Streetscape Concept Plan* is submitted that demonstrates how the Performance Criteria are met, showing:

- location of existing vegetation to be removed or conserved;
- location, species and general character of tree planting, and hard and soft landscape treatment;
- location and indicative treatment of building form (eg setbacks, front elevation, garage/carpport location and design, and front garden treatments).

AND

A1.2 For infill housing that abuts an existing public street, information should be submitted that demonstrates how the development fits in with an existing attractive streetscape or any statement of future urban character for that area.

* This plan may form part of or include a landscape plan. The need to complete such a plan will depend on local implementation requirements.

ELEMENT B1

Streetscape and Landscape *continued*

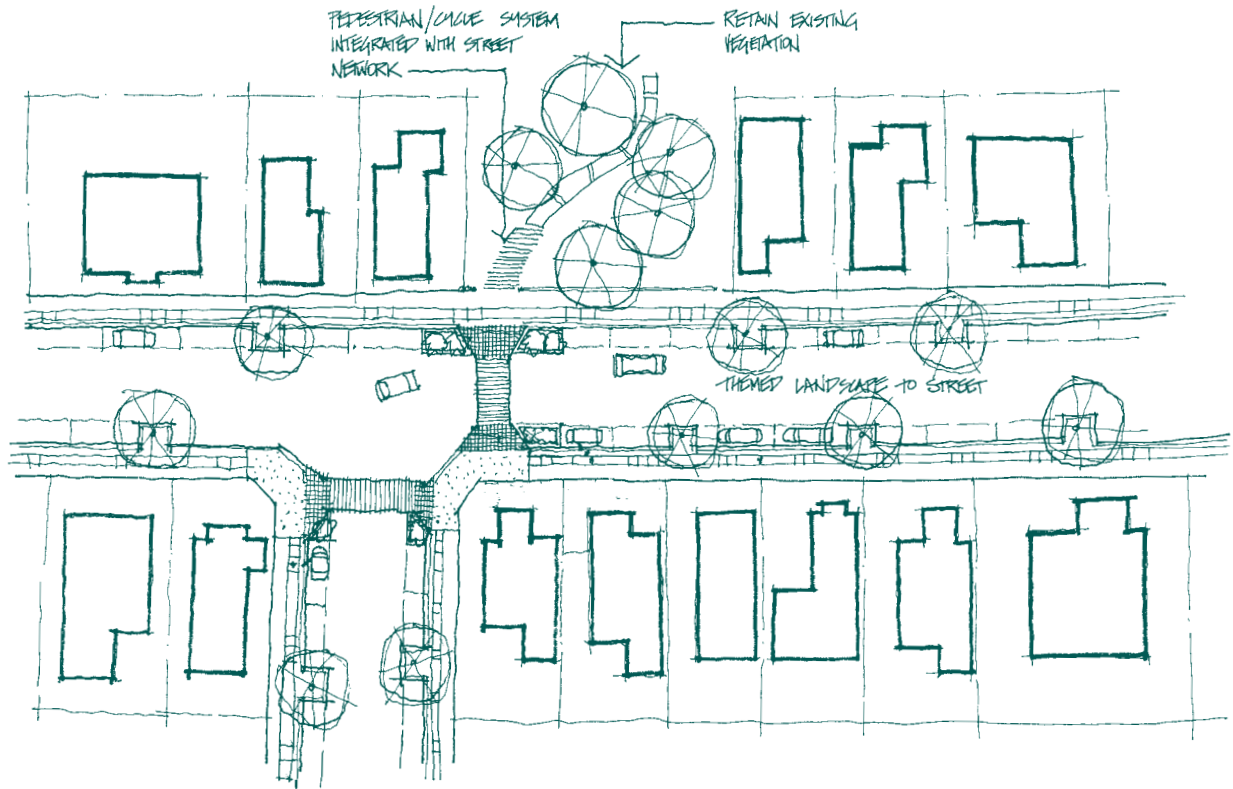

Figure 11: Streetscape concept plan

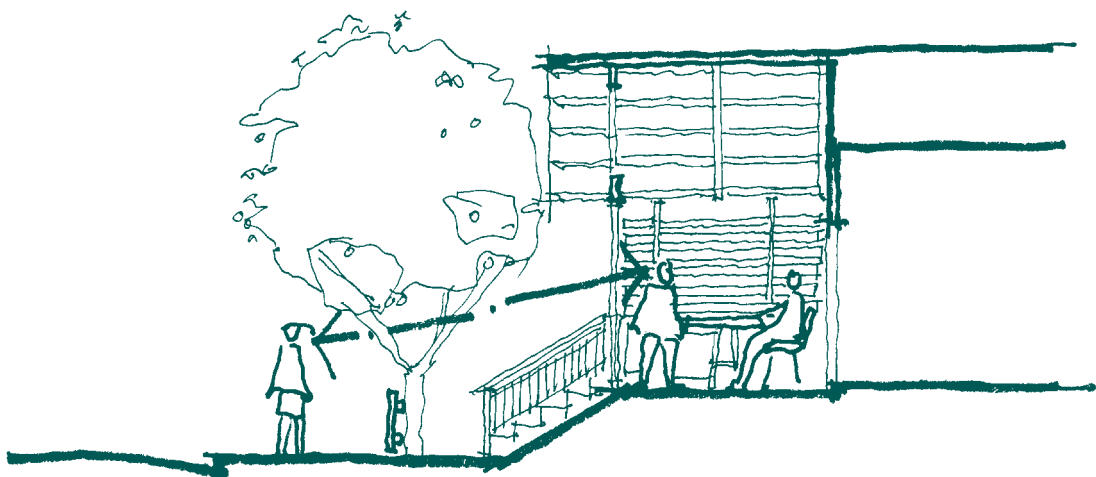

Figure 12: "Natural" surveillance to the street

ELEMENT B2

Building Appearance and Neighbourhood Character

INTENT

To ensure that a dwelling's appearance from public streets and adjoining sites is attractive and visually compatible with either attractive surrounding development or the future urban character of the area, as identified in a local government's planning scheme.

PERFORMANCE CRITERIA

The intent may be achieved where:

- P1** The frontage of the dwelling and its entry is readily apparent from the street.
- P2** The dwelling's height at the street frontage maintains a compatible scale with adjacent development.
- P3** The dwelling is designed to reflect relevant features of the prevailing character of surrounding streetscapes, features and built form character that have been identified as part of the desired future character of the area.
- P4** The dwelling is designed to enhance the identified desirable existing built form character by translating the following characteristics found in the surrounding built form into innovative design solutions:
- mass and proportion;
 - building materials, patterns, textures, colours, and decorative elements;
 - ground-floor height above natural ground level;
 - floor to ceiling height;
 - roof form and pitch;
 - facade articulation, detailing, and window and door proportions;
 - verandahs, eaves and parapets;
 - driveway crossovers, fence style and alignment.

ACCEPTABLE SOLUTIONS

The Acceptable Solutions illustrate ONE WAY of meeting the associated Performance Criteria:

- A1.1** A Streetscape Concept Plan and/or Landscape Plan is submitted that demonstrates how the Performance Criteria are met.
- OR
- A1.2** A dwelling adjacent to the public street addresses the street by having a front door or living room or kitchen windows facing the street.
- A2** Differences in building height between existing buildings and a new dwelling are not more than one storey when viewed from the public street and adjoining properties. This requirement applies to the building for a depth of one room.
- (in partial satisfaction of P3 and P4)*
- A3.1** A Development Plan, Streetscape Concept Plan and/or Landscape Concept Plan is submitted that demonstrates how the Performance Criteria are met.
- OR
- A3.2** The dwelling's design, roof form, detailing and materials visible from public areas and adjoining properties are not in strong visual contrast with the character of attractive neighbouring buildings.

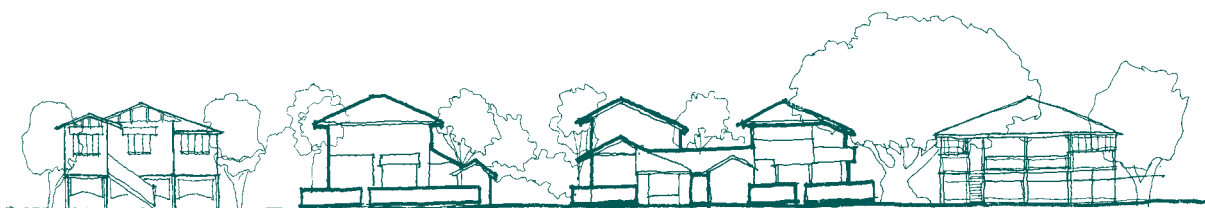

Figure 13: Building appearance and neighbourhood character

ELEMENT B2

Building Appearance and Neighbourhood Character continued

PERFORMANCE CRITERIA

- P5** New development complements or enhances any treed landscape character of the area by:
- providing sufficient open space for the planting of trees to complement the landscape character of the neighbourhood;
 - retaining and protecting existing vegetation where possible;
 - protecting neighbouring trees from damage to their root systems;
 - using building footing designs, where necessary, that allow root growth of large trees.
- P6** The dwelling's design, detailing and finish provide an appropriate scale to the street, add visual interest and enable differentiation between dwellings when viewed from public streets.
- P7** The dwelling is designed and sited to acknowledge the private open space of surrounding development, by:
- keeping upper story parts of buildings away from neighbouring private open space so as to avoid an unreasonable sense of visual enclosure; and
 - using articulation, colour and detailing to reduce visual bulk.
- P8** Garages and parking structures are sited and designed so as not to dominate the street frontage, by:
- minimising the frontage width;
 - minimising obtrusive projections of the structures beyond the main face of the building; and
 - ensuring that roof form, materials and detailing complement that of the associated dwelling.

ACCEPTABLE SOLUTIONS

(in partial satisfaction of P8)

- A8** Carports and garages are designed to be compatible with the dwelling design and have a maximum internal width of garage or carport of 6m or 50% of the frontage width, whichever is the less, where they face the street.

ELEMENT B3

Fences and Walls

INTENT

To ensure that front fences and walls, where used, improve amenity for residents and contribute positively to the streetscape and adjacent buildings.

PERFORMANCE CRITERIA

The intent may be achieved where:

- P1** Subject to P2, front fences and walls enable some outlook from a dwelling to the street to achieve safety and surveillance.
- P2** Where appropriate, front fences and walls enable use of private open space abutting the street and/or provide an acoustic barrier if traffic noise is excessive.
- P3** Front fences and walls assist in highlighting entrances.
- P4** The design and materials of front fences and walls are compatible with the associated development and with attractive fences and walls in the nearby visible locality.
- P5** Front fences and walls are compatible with facilities in the street frontage area, such as mail boxes and garbage collection areas.
- P6** The use and/or design of fences and walls in streetscapes of significance is appropriate to the heritage context.
- P7** Where overland water flows are probable (eg in hot-humid and hot-arid climates) fences with strip footings provide for the movement of surface stormwater.

ACCEPTABLE SOLUTIONS

The Acceptable Solutions illustrate ONE WAY of meeting the associated Performance Criteria.

(in relation to P1 and P2)

- A1** A Streetscape Concept Plan and/or Landscape Plan is submitted that demonstrates how the Performance Criteria are met.
- OR
- A2** Front fences and walls are no more than 1.2m high if solid (forward of the building line). This height may be increased to 1.8m if the fence has openings which make it not less than 50% transparent;
- OR
- A3** Solid front fences and walls to 1.8m high are limited to where:
- the main private open space is in front of the dwelling;
- OR
- traffic volumes exceeds 6000vpd;
- OR
- climatic considerations would provide a benefit to the dwelling or outdoor space.
- PROVIDED THAT:
- the width is limited to a maximum of 75% of the frontage where private open space fronts the street;
 - some surveillance of the street is maintained from the dwelling;
 - fences do not exceed 10m in length without some articulation or detailing to provide visual interest.

ELEMENT B3

Fences and Walls *continued*

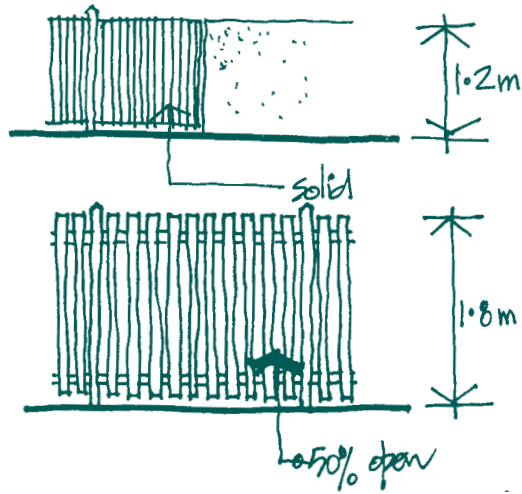

Figure 14: Typical front fences / walls

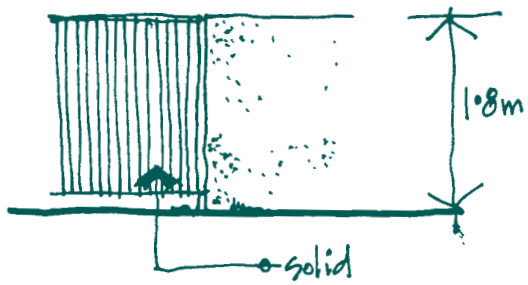

Figure 15: Fences for special privacy or noise control

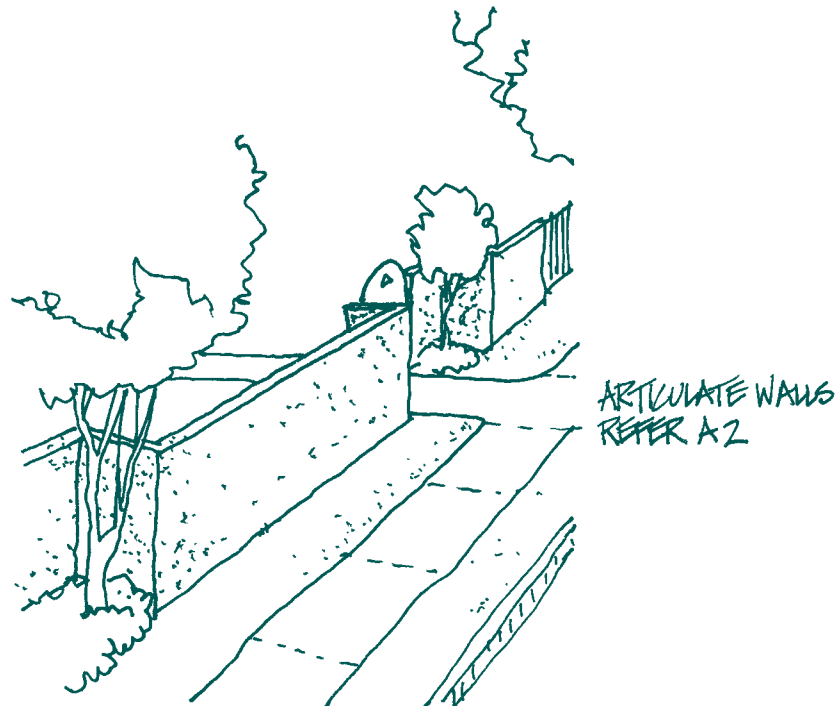

Figure 16: Fence / wall articulation

ELEMENT B4

Bushfire Protection

INTENT

To reduce the level of fire risk associated with building in bushfire-prone areas by adopting suitable passive and active protection measures relating to siting, layout, design and construction techniques, and landscaping.

PERFORMANCE CRITERIA

The intent may be achieved where:

- P1** The dwelling design and materials is selected to maximise resistance to fire.
- P2** In moderate and high-risk bushfire areas an external sprinkler system is fitted to protect the walls and roof of a dwelling.
- P3** The dwelling site is provided with a safe and secure water supply for fire fighting and protection.
- P4** Landscaping is designed to provide protection to buildings and not increase the level of bushfire risk.
- P5** The site layout of the dwelling, paths and landscaping creates a building protection zone and allows for ease of access to and from dwellings and other buildings.
- P6** Design of the roof drainage system is appropriate to the bushfire hazard of the area.

ACCEPTABLE SOLUTIONS

The Acceptable Solutions illustrate ONE WAY of meeting the associated Performance Criteria.

- A1** The dwelling complies with the Building Code of Australia requirements for construction in bushfire-prone areas, and with relevant State or local authority regulations.

DEFINITIONS

Acceptable Solution means an example of what may satisfy the relevant Performance Criteria (they should not preclude other solutions).

Access place means a minor cul-de-sac street providing local residential access, with shared traffic, pedestrian and recreation use.

Access street means a street providing local residential access with shared traffic, pedestrian and recreation use with local traffic access priority.

AMCORD means the Australian Model Code for Residential Development – A national resource document for residential development – November 1995.

AS means Australian Standard.

Balcony means any balustraded platform, 0.3 metres or more above adjacent finished ground level, either cantilevered or supported over open space, with access from the building via a door or window and with a minimum width of 1 metre.

BCA means Building Code of Australia.

Building envelope means a diagram drawn on a lot of a subdivision plan to the requirements of the Responsible Authority defining the limits for the siting and/or wall height of any dwellings and/or outbuildings, private open space, driveways and/or garages/carports.

Building height means the distance between natural surface level of the ground and the apex of a building's roof, but not including any receiving antennae, chimneys or flues.

Carriageway means the area of street or road reserve which is provided for the movement or parking of vehicles.

Casual surveillance refers to the ability to informally observe an area to enhance the level of security.

Collector Street – A street providing for local residential access and local traffic movement within performance limits defined in Queensland Streets.

Communal open space means usable community open space for recreation and relaxation of residents of a housing development and which is under the control of a body corporate or equivalent.

Communal street means the carriageway providing access to a housing development and which is under the control of a body corporate or equivalent.

Community Title refers to title given under the provisions of the Body Corporate and Community Management Act 1997 (BCCM Act) (formerly known as 'group title' under the Building Units and Group Titles Act 1980, which has been replaced by the BCCM Act).

Crossover refers to the paved accessway between the carriageway of a street and a development site.

Detached dwelling means a separate house on an individual lot (including a community title lot).

Development Area means an area identified as having potential for housing following strategic planning and study.

Duplex means a building comprising two attached dwellings on the same lot.

Established area means an existing neighbourhood where the vast majority of land is developed.

Flat or apartment (including attached to a shop, office etc) includes one or more of the following:

- units constructed over the top of each other;
- shared communal open space in lieu of or as well as private open space;
- shared parking/access arrangements;
- attached to a detached dwelling (with shared access/site facilities).

Frontage means the street alignment at the front of a lot and in the case of a lot that abuts two or more streets, the boundary of which, when chosen, would enable the lot to comply with these provisions.

Habitable room means a room used for normal domestic activities that includes:

- a bedroom, living room, lounge room, music room, television room, kitchen, dining room, sewing room, study, playroom and sunroom,

but excludes:

- a bathroom, laundry, water closet, food storage pantry, walk-in wardrobe, corridor, hallway, lobby, photographic darkroom, clothes drying room, and other spaces of a specialised nature occupied neither frequently nor for extended periods.

Height of a wall at any point for the purpose of determining its setback from a boundary means the vertical distance between the top of the eaves at the wall line, parapet or flat roof (not including a chimney), whichever is the highest, and the natural ground level of the lot boundary at a point at right-angles to the wall. Where a skillion roof occurs, the height shall be measured as the median height of the wall. When a triangular gable roof occurs, the heights shall be measured as the height of the wall together with one-third of the vertical height of the gable.

DEFINITIONS *continued*

Infill housing is a general term used for new housing in existing residential areas and usually involving the use of a vacant site or the removal of an existing dwelling to enable construction of a larger number of dwellings.

Intent (or Element Intent) means a statement of the desired outcomes to be achieved in the completed development, relating to particular Design Elements.

Landscape plan means a plan or document outlining the extent, type and location of proposed landscaping and planting.

Lot means an area of topographical space shown on an approved plan of subdivision and on which it is intended to construct a dwelling or dwellings.

Multi-unit dwellings means the development of more than one dwelling on a site where facilities are shared (eg access, parking, communal open space/facilities).

Nature strip refer to verge.

Outermost projection means the outermost projection of any structural part of a building or other structure including, in the case of a roof, the outside face of the fascia, or the roof structure where there is no fascia, but does not include any rainwater fittings, ornamental or architectural attachment.

Performance Criteria means criteria to be used in the preparation, submission and assessment of development proposals for measuring performance of the proposals against the Element Intent.

Plan of Development means a plan approved as part of a planning process which identifies the precise conditions for housing and other activities.

Private open space means an open area of land or building attached to a dwelling (eg balcony or roof garden) intended for the exclusive use of the occupants of the dwelling, and located and designed so as to offer visual privacy to the occupants.

Public open space means land used or intended for use for recreational purposes by the public and includes parks, public gardens, riverside reserves, pedestrian and cyclist accessways, playgrounds and sports grounds.

Setback means the shortest distance measured horizontally from the outermost projection of the building or other structure concerned to the vertical projection of the boundary of the allotment.

Site analysis involves the identification and analysis of the existing urban character and adjacent properties to assist in understanding the locality and the development of a range of appropriate design responses.

Site Analysis Plan means a plan which demonstrates an appreciation of a site and its context to identify opportunities and constraints on site layout and design. The plan may include information on topography and services, existing buildings on site, vegetation on site, adjoining property conditions, views, noise sources and street character and context.

Site density means the ratio of dwellings to the area of the site they occupy (including communal streets and communal open space).

Site means the lot(s) of land on which a building stands or is to be erected.

Storey means a space within a building which is situated between one floor level and the floor level next above, or if there is no floor above, the ceiling or roof above. It does not include a room contained wholly within the roof space or a parking area contained wholly within a basement which is below the natural ground level.

Street – Any street, lane, square, court, alley and other carriageways whose primary purpose is providing access to residential buildings.

Street pavement see Carriageway.

Street reserve means the land set aside for a street pavement and verge.

Streetscape plan means the portion of the development plan showing the visible components within a street (or part of a street) between facing buildings, including the form of buildings, setbacks, fencing, landscaping, driveway and street surfaces, utility services and street furniture such as lighting, signs, barriers and bus shelters.

Subdivision means the division of a parcel of land into two or more parts for the purpose of enabling any of the lots to be disposed of separately.

Verge means that part of the street or road reserve between the carriageway and the boundary of adjacent lots (or other limit to street reserve). It may accommodate public utilities, footpaths, stormwater flows, street lighting poles and planting.

Wall height refer to Height of Wall.

Weighting means a process of determining priorities for various Design Elements and Performance Criteria in the consideration of designing and assessing development proposals.

Window includes a roof skylight, glass panel, glass brick, glass louvre, glazed sash, glazed door, translucent sheeting or other device which transmits natural light directly from outside a building to the room concerned.

REFERENCES

Australian Road Research Board (ARRB) (1989): Structural design guide for residential street pavements, Special Report No. 41 prepared by P.J. Mulholland.

Department of Primary Industries-Water Resources (DPI), Institute of Municipal Engineering Australia, Qld. Division, Brisbane City Council (November 1994): Queensland urban drainage manual, (OUDM) prepared by Neville Jones and Associates Pty Ltd and Australian Water Engineering.

Institute of Municipal Engineering Australia, Qld Division (IMEAQ) (1993, incorporating 1996 update): Queensland streets-design guidelines for subdivisional streetworks, prepared by Weathered Howe Pty Ltd.

Whelans and Halpern Glick Maunsell (1994): Planning and management guidelines for water-sensitive urban (residential) design, Report prepared for Dept Planning and Urban Development, Water Authority of WA and EPA, Perth.

APPENDIX

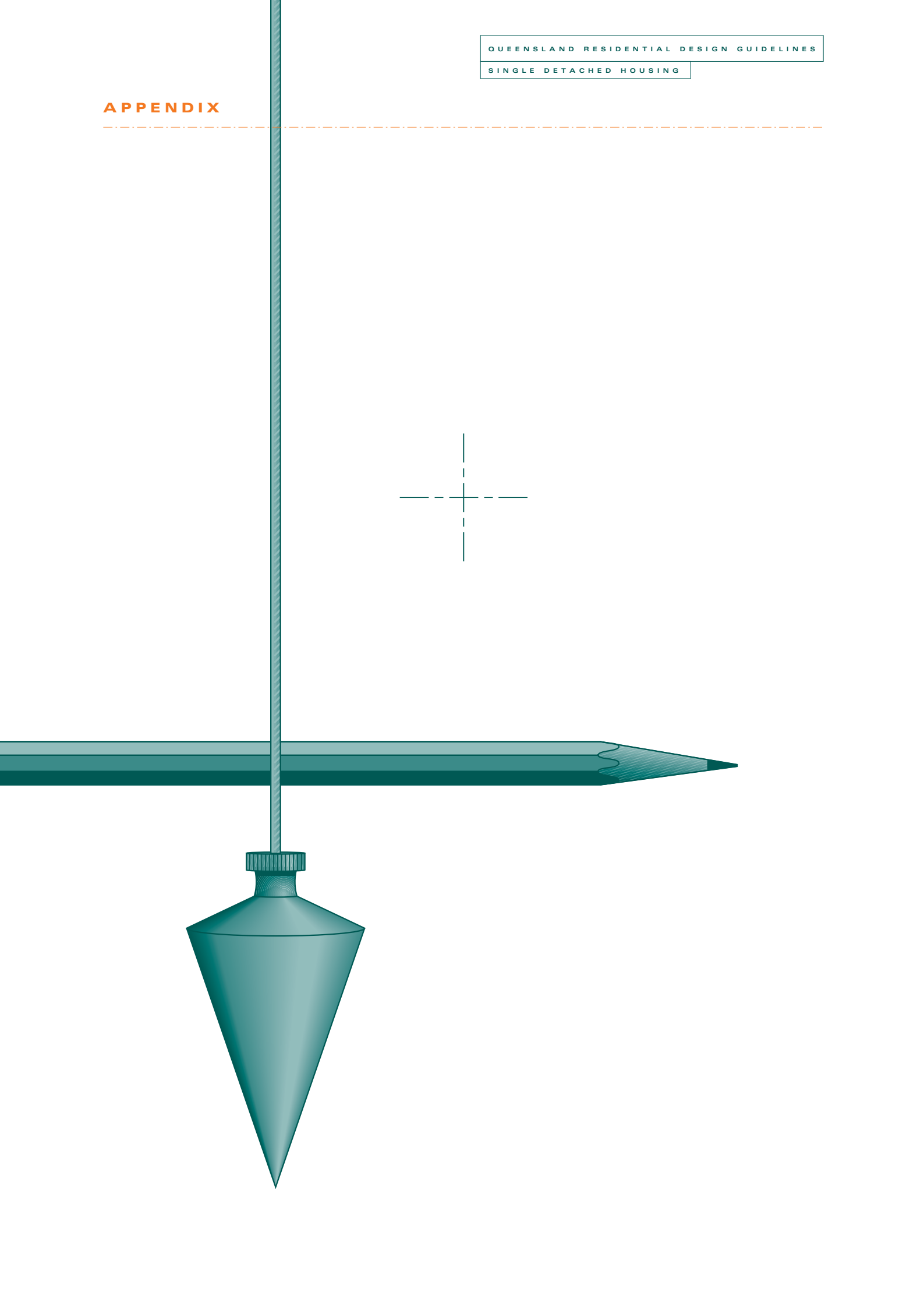

ELEMENT C1

Safety and Security

INTENT

To provide personal and property security for residents and visitors and enhance perceptions of community safety.

PERFORMANCE CRITERIA

The intent may be achieved where:

- P1** The dwelling and/or the private open space area is designed to overlook the streets and other public areas to provide casual surveillance.
- P2** Site planning, fences, landscaping and other features clearly define the site.
- P3** The dwelling entry provide a sense of security for both residents and visitors.
- P4** Landscape and fencing do not present a security risk by screening doors, windows and major paths.

SUGGESTED SOLUTIONS

The Suggested Solutions illustrate ONE WAY of meeting the associated Performance Criteria.

- A1** A dwelling adjacent to streets or open space has at least one habitable room window with an outlook to that area.
- OR
- A1.1** The primary area of private open space overlooks the street and/or other public areas.
- A3** The dwelling design allows visitors who approach the front door to be seen without the need to open the door.

ELEMENT C2

Design for Climate

INTENT

To facilitate energy and water conservation measures in and around housing that will assist in establishing ecologically sustainable residential environments, through the reduction in household use of fossil fuels and greenhouse gas emissions and the use of renewable energy sources.

PERFORMANCE CRITERIA

The intent may be achieved where solar access is available and where:

In all climates

- P1** Building envelopes and internal layouts are designed to minimise energy consumed for heating and cooling.

- P2** Windows are located, sized and shaded to facilitate good thermal performance.

- P3** Dwellings have an area of roof, with appropriate orientation and pitch, that is suitable for the installation of solar collectors and photovoltaic cells.

- P4** Building materials and insulation assist in providing acceptable thermal conditions.

- P5** Air movement within dwellings is designed to provide acceptable thermal conditions.

- P6** Building materials, appliances and fuel sources are selected to minimise energy requirements and greenhouse gas emissions.

- P7** Landscape design assists microclimate management to conserve energy and water.

- P8** Building and landscape design incorporate techniques for conserving mains water.

SUGGESTED SOLUTIONS

The Suggested Solutions illustrate ONE WAY of achieving the Performance Criteria:

In all climates

(in relation to P1 to P5)

- A1** There is a minimum rating of four stars for any dwelling on its own separate lot, or four stars for 50% of dwellings and three stars for the remaining dwellings within a multi-unit housing development, under an accredited House Energy Rating Scheme.

OR

(in partial satisfaction of P1 to P5)

- A2.1** Doors, windows and other openings have adequate draught control.

- AND

- A2.2** Mechanically heated or cooled areas can be closed off from other areas of the dwelling.

- AND

- A2.3** Buildings (other than in the hot-humid climate zone) are sited within the preferred orientation range shown in Figure 17.

- AND

- A2.4** A north-facing room is provided, capable of use as a living area.

- AND

- A2.5** Ceiling and wall insulation is provided to at least the level recommended in AS 2627.1-1993 for the locality.

- AND

ELEMENT C2

Design for Climate continued

PERFORMANCE CRITERIA

In temperate climates

- P9** Dwellings are sited and designed to maximise solar access to north-facing windows of living areas and principal areas of open space, having regard to slope, views, existing vegetation and overshadowing.
- P10** Windows are appropriately sized and shaded to reduce summer heat load and permit entry of winter sun.

In cool-temperate climates

- P11** Dwellings are sited and designed to maximise solar access to north-facing windows of living areas and principal areas of open space, having regard to slope, views, existing vegetation and overshadowing.
- P12** Dwellings are designed for maximum solar access during cooler months.
- P13** Dwellings and landscaping are designed to ensure protection from winter winds.
- P14** Dwellings are mainly constructed of materials with high thermal mass.

SUGGESTED SOLUTIONS

In all climates (continued)

- A2.6** External clothes drying areas with access to sunlight and breezes are available.

In temperate climates

(in partial satisfaction of P9 and P10)

- A9.1** Windows to north-facing living areas receive at least 3 hours of sun between 9am and 5pm on 21 June over a portion of their surface.

AND

- A9.2** North-facing windows to living areas of neighbouring dwellings do not have sunlight reduced to less than the above 3 hours.

AND

- A9.3** Materials of high thermal mass are used for living areas and are located to maximise the absorption of heat from air circulating in the dwelling and from the winter sun.

In cool-temperate climates

(in partial satisfaction of P11 to P14)

- A11.1** Windows to north-facing living areas receive at least 3 hours of sun between 9am and 5pm on 21 June over a portion of their surface.

AND

- A11.2** North-facing windows to living areas of neighbouring dwellings do not have sunlight reduced to less than the above 3 hours.

AND

- A11.3** East-facing windows (with external shading to restrict summer sun) are provided for morning sunlight during cooler months.

ELEMENT C2

Design for Climate continued

PERFORMANCE CRITERIA

In hot-humid climates

- P15** Dwellings are sited to maximise the use of cooling breezes and provide natural ventilation.
- P16** Dwellings are designed to:
- minimise the need for mechanical cooling;
 - maximise cross-ventilation;
 - use shade structures over all windows and external doors;
 - naturally ventilate roof spaces;
 - provide for covered outdoor living areas;
 - avoid long walls along western boundaries.
- P17** Fences are of semi-open construction for breeze penetration.
- P18** Trees and vegetation provide as much shade as possible both on-site and on-street.

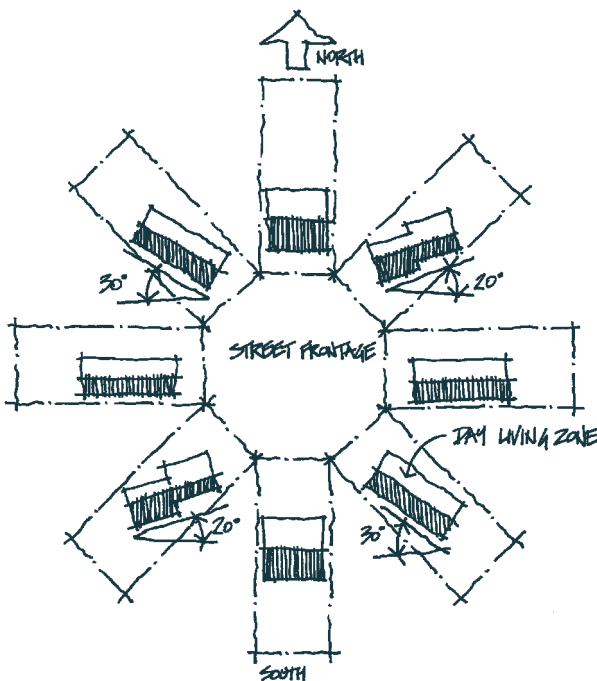

Figure 17: Suggested positioning of houses on sites with varied aspects to achieve low-energy housing in temperate climate zones

SUGGESTED SOLUTIONS

In hot-humid climates

(in partial satisfaction of P15 to P18)

- A15.1** Buildings are designed with openings on opposite or adjacent walls for cross-ventilation.
- AND
- A15.2** All habitable rooms are naturally ventilated, with a minimum openable area of 5% of the floor area of that room.
- AND
- A15.3** All external openings are protected from direct sunlight by permanently fixed shade devices.
- AND
- A15.4** Roof spaces are ventilated with louvre openings (eg gable end) or by roof-mounted ventilators (subject to Cyclone Code).
- AND
- A15.5** Verandahs and balconies are provided and are not less than 10m² with a minimum dimension of 2.5m, and are covered for a minimum of 30% of their area.
- AND
- A15.6** Roofs are lightweight and light-coloured, and roofs and walls are insulated to at least the level recommended in AS 2627.1-1993.
- AND
- A15.7** A vapour barrier membrane is installed on the outside of the bulk insulation. Perforated breather paper is installed in all other walls (to restrict condensation buildup).
- AND
- A15.8** Lightweight materials are used in buildings in the most northern and hotter regions, particularly within bedrooms.

ELEMENT C2

Design for Climate continued

PERFORMANCE CRITERIA

In hot-arid climates

- P19** Dwellings incorporate courtyards with summer shade and vegetation.
- P20** Dwellings are designed to provide midday shade all year round but with some early morning solar penetration.
- P21** Dwellings are sited to maximise the use of cooling breezes.
- P22** Dwellings are designed to:
 - minimise the need for mechanical cooling;
 - maximise cross-ventilation;
 - use shade structures over all windows and external doors;
 - naturally ventilate roof spaces;
 - provide for covered outdoor living areas;
 - avoid long walls along western boundaries.
- P23** Trees and vegetation provide as much shade as possible both on-site and on-street.

SUGGESTED SOLUTIONS

In hot-arid climates

(in partial satisfaction of P19 to P23)

- A19.1** Dwellings and landscaping are sited and designed to provide shade to walls and the roof all year round.
AND
- A19.2** Courtyards are provided with summer shade and vegetation.
AND
- A19.3** Walls to living areas are constructed using materials of high thermal mass and walls to bedrooms are constructed using materials of low thermal mass.
AND
- A19.4** Dwellings are sited to maximise available cool breezes.
AND
- A19.5** Dwellings are designed with openings on opposite or adjacent walls for cross-ventilation.
AND
- A19.6** All habitable rooms are naturally ventilated, with a minimum openable area of 5% of the floor area of that room.
AND
- A19.7** All external openings are protected from direct sunlight by shade devices.
AND
- A19.8** Roof spaces are ventilated with louvre openings (eg gable end) or by roof-mounted ventilators and are bulk insulated.

ELEMENT C2

Design for Climate *continued*

PERFORMANCE CRITERIA

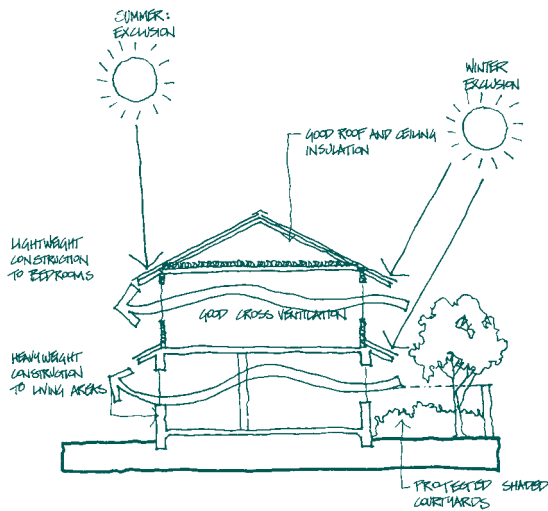

Figure 18: Design for climate
Hot-arid climate

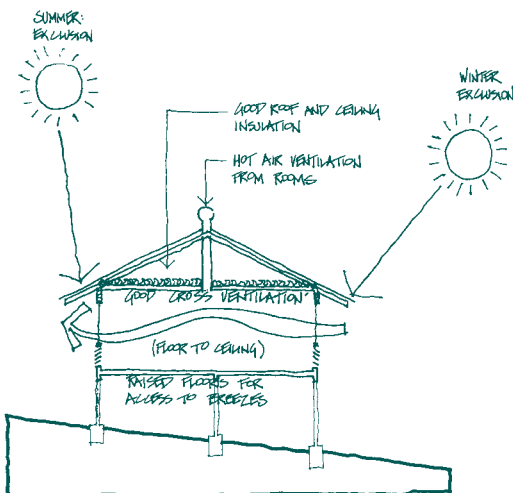

Figure 19: Design for climate
Hot-humid climate

SUGGESTED SOLUTIONS

In hot-arid climates (continued)

AND

A19.9 Verandahs and balconies are provided and are not less than 10m² with a minimum dimension of 2.5m, and are covered for a minimum of 30% of their area.

AND

A19.10 Roofs are lightweight and light-coloured, and roofs and walls are insulated to at least the level recommended in AS 2627.1-1993.

AND

A19.11 A vapour barrier membrane is installed on the inside of the bulk insulation in order to restrict condensation buildup.

AND

A19.12 The house is designed with a longer east-west axis.

AND

A19.13 Windows are located on the north and south walls only.

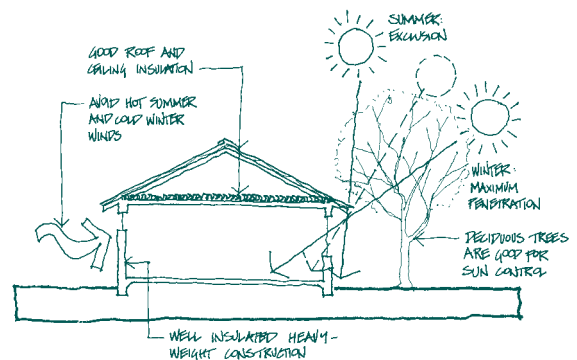

Figure 20: Design for climate
Cool-temperate / temperate climate

ELEMENT C3

Housing on Traffic Routes

INTENT

To ensure that housing located next to major roads is designed and constructed in a manner that reduces the adverse impact of traffic and leads to attractive streetscapes, functional roads and comfortable living conditions.

PERFORMANCE CRITERIA

The intent may be achieved where:

- P1** The dwelling is sited in a manner which:
- minimises the infiltration of noise into the building;
 - provides an acoustic barrier for private open space;
 - reduces reflection of noise on to other buildings;
 - precludes the need to reverse on to a major road (for new lots and where the nature of an existing lot makes this possible).
- P2** Front fences and walls are designed to:
- supplement the noise control of the dwelling facade;
 - enable some outlook to the street;
 - highlight the entrance;
 - provide continuity and visual interest to the streetscape.
- P3** Higher side boundary fences and walls are designed or treated to reduce the angle of view to the noise source and minimise reflection onto the facade.
- P4** The room layout within the dwelling is arranged to reduce the impact of noise on the rooms which are most sensitive to noise (eg living rooms, bedrooms and recreation rooms).
- P5** Balconies and other external building elements are located, designed and treated to minimise infiltration and reflection of noise onto the facade.
- P6** The building plan, walls, windows, doors and roof are designed and detailed to reduce intrusive noise levels.

SUGGESTED SOLUTIONS

The Suggested Solutions illustrate ONE WAY of meeting the associated Performance Criteria.

(in partial satisfaction of P1 to P8)

- A1** Buildings are constructed in accordance with Australian Standard 3671: Acoustics – Road Traffic Noise Intrusion, Building Siting and Construction, and Australian Standard 2107: Acoustics – Recommended Design Sound Levels and Reverberation Times for Building Interiors.

ELEMENT C3

Housing on Traffic Routes continued

PERFORMANCE CRITERIA

- P7** The integrity of the wall as a barrier to noise is maintained while providing adequate cross-flow ventilation and allowing natural light to penetrate the building.
- P8** The design and appearance of the facade of the dwelling facing the traffic route achieve human scale and proportion, and reflect and reinforce the desired residential character of the area.
- P9** Landscaping, where required, is designed which:
- provides a sense of separation between the road and the private living environment;
 - is durable and suited to the conditions of the road environment.

SUGGESTED SOLUTIONS

ELEMENT C3

Housing on Traffic Routes *continued*

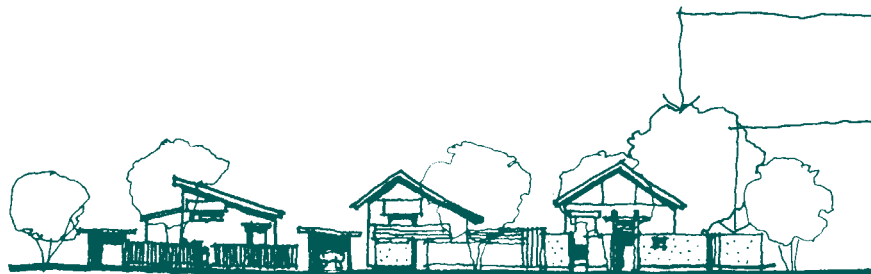
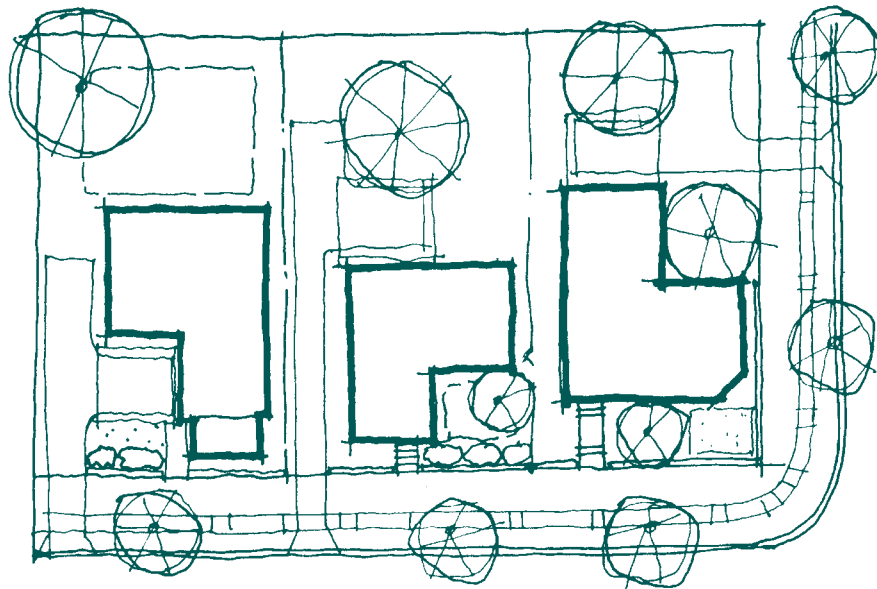

TREES AND PLANTINGS ON THE STREET MAKE A VISUAL BARRIER AND CAN SOFTEN A HARSH STREET ENVIRONMENT.

HOUSING, WALL AND FENCING DESIGNED FOR NOISE CONTROL CAN BE ARTICULATED AND VARIED.

NOISE CONTROL SHOULD NOT DETRACT FROM THE STREET CHARACTER AND SENSE OF IDENTITY
(NOTE: THIS ELEVATION SHOWS HOUSE FORMS BEHIND FENCES, WALLS AND LANDSCAPE)



TREES AND PLANTING ON THE STREET CREATE A VISUAL BARRIER AND SOFTEN THE STREET ENVIRONMENT

NOISE BARRIER WALLS AND FENCES CAN BE ARTICULATED AND VARIED TO ADD TO THE STREET SCAPE

ARTICULATION AND IDENTITY AT THE STREET FACADE
(NOTE: THIS ELEVATION SHOWS FENCES, WALLS AND LANDSCAPE ONLY)

Figure 21: Housing on traffic routes

ELEMENT C4

Privacy

INTENT

To site and design dwellings to meet projected user requirements for visual privacy, and to protect the visual privacy of nearby residents in their dwellings and private open space.

PERFORMANCE CRITERIA

P1 Direct overlooking of main internal living areas and private open spaces of other dwellings is minimised by building layout, location and design of windows and balconies, screening devices and landscape, or remoteness. (Effective location of windows and balconies to avoid overlooking is preferred to the use of screening devices, high sills or obscured glass. Where these are used, they should be integrated with the dwelling design and have minimal negative effect on residents' or neighbours' amenity).

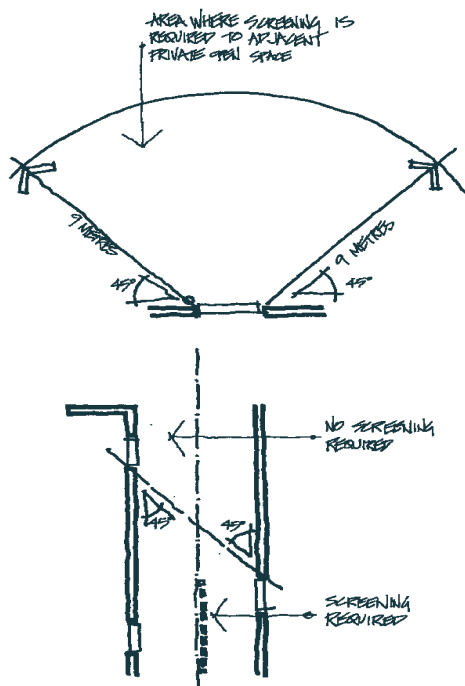

Figure 22: Privacy
Outlook from windows

SUGGESTED SOLUTIONS

The Suggested Solutions illustrate ONE WAY of meeting the associated Performance Criteria.

A1.1 Habitable room windows with a direct outlook to the habitable room windows in an adjacent dwelling within 9m:

- have suitable screening devices installed;

OR

- are offset from the edge of one window to the edge of the other by a distance sufficient to limit views into the adjacent windows;

OR

- have sill heights of 1.7m above floor level;

OR

- have fixed obscure glazing in any part of the window below 1.7m above floor level.

AND

A1.2 Outlook from windows, balconies, stairs, landings, terraces and decks is obscured or screened where a direct view is available into the private open space of an existing dwelling.

If screening is used, the view of the area overlooked must be restricted within 9m and beyond a 45° angle from the plane of the wall containing the opening, measured from a height of 1.7m above floor level (see Figure 22).

No screening is required where:

- windows are in bathrooms, toilets, laundries, storage rooms or other non-habitable rooms and they have translucent glazing or sill heights of at least 1.7m;
- windows are in habitable rooms and they have sill heights of 1.7m or more above floor level or translucent glazing to any part of a window less than 1.7m above floor level.

AND

ELEMENT C4

Privacy *continued*

PERFORMANCE CRITERIA

SUGGESTED SOLUTIONS

A1.3 Direct views described in A2.2 may be obscured by solid translucent screens or perforated panels or trellises which have a maximum of 25% openings, and which are:

- permanent and fixed
- of durable materials
- designed and painted or coloured to blend in with the development.

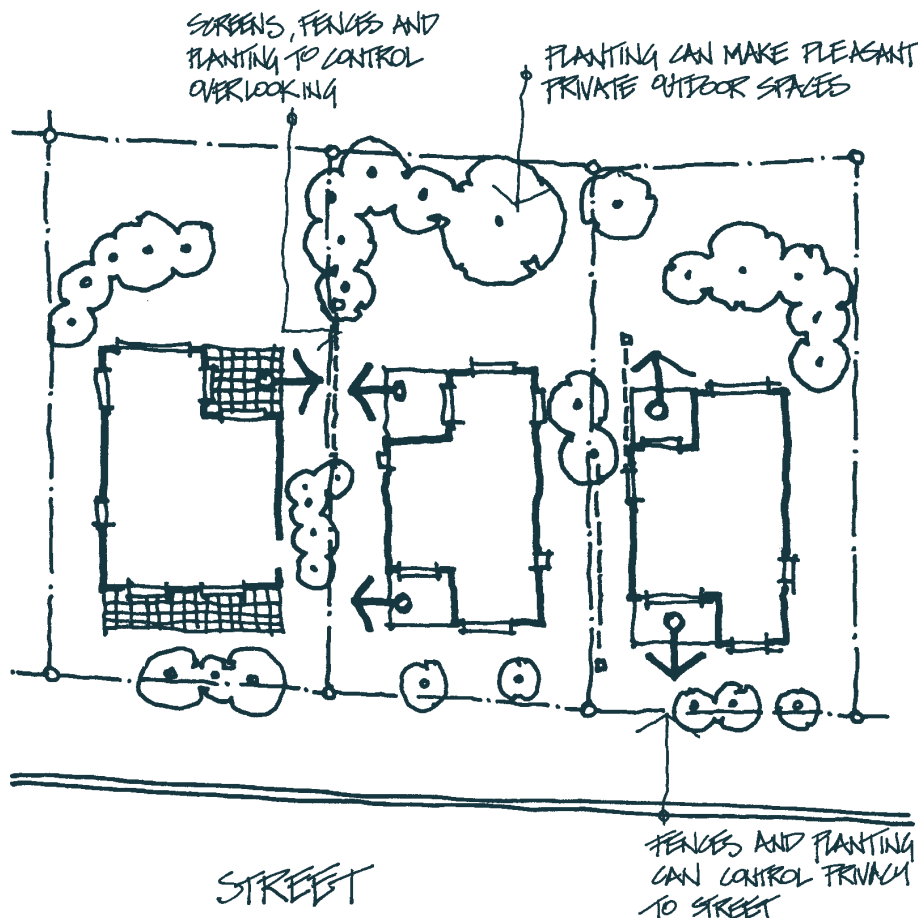

Figure 23: Privacy
Street / allotment

QUEENSLAND RESIDENTIAL
DESIGN GUIDELINES

Attached

h o u s i n g

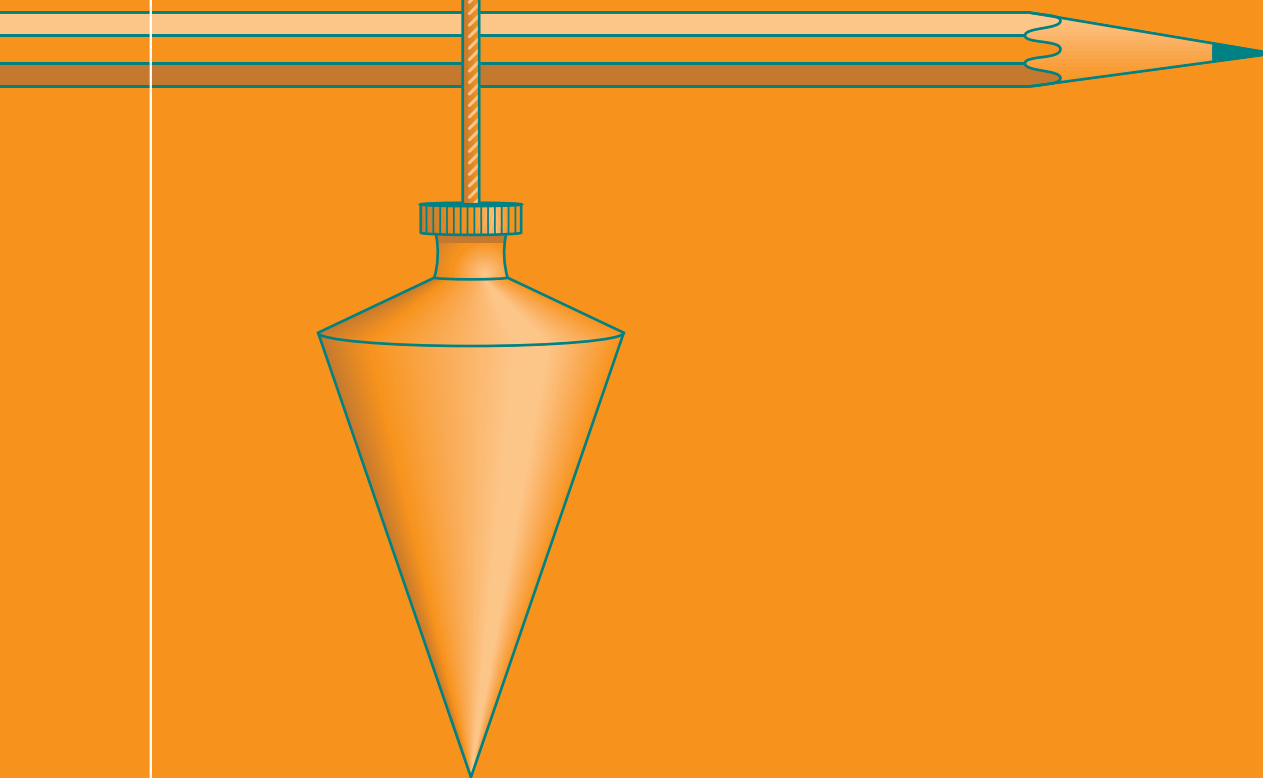

TABLE OF CONTENTS

Part 2 – Attached Housing

1.0	INTRODUCTION	1
1.1	APPLICATION OF DESIGN GUIDELINES	2
1.2	THE PERFORMANCE APPROACH	2
1.3	SITE ANALYSIS	3
1.4	DESIGN ELEMENTS	7
A GENERAL		
A1	Street Setbacks	7
A2	Building Envelope and Siting	9
A3	Storm Drainage	12
A4	On-site Carparking and Access	15
A5	Private Open Space	18
A6	Communal Open Space and Landscaping	20
A7	Site Facilities	23
A8	Site Works	24
B SITE SPECIFIC		
B1	Streetscape and Landscape	26
B2	Building Appearance and Neighbourhood Character	29
B3	Fences and Walls	31
B4	Bushfire Protection	33
B5	Housing on Traffic Routes	34
DEFINITIONS		37
REFERENCES		39
APPENDIX		
C ADVISORY DESIGN ELEMENTS		
C1	Safety and Security	43
C2	Design for Climate	45
C3	Privacy	50
C4	Dwelling Unit Entry and Interior	52

1.0 Introduction

The Queensland Residential Design Guidelines have been produced for use by planners, designers, local government development control officers, builders, and developers involved in housing and residential development in Queensland.

The Guidelines are derived from the provisions of the Australian Model Code for Residential Development – A National Resource Document (AMCORD 1995), with modifications to suit Queensland conditions.

The Guidelines have four sections:

- 1 Single Detached Housing – for planning, design, and development of detached houses.
- 2 Attached Housing – for planning, design, and development of all forms, types, and arrangements of attached housing up to 3 storeys in height, or 3 storeys over carparking.
- 3 Integrated Development – for integrated planning, design, and development of projects comprising 2 or more houses (includes residential components of mixed-use projects).
- 4 Subdivision – for planning, design and development of land subdivision for residential purposes, prior to housing construction.

Each section:

- comprises design elements presented using a performance-based approach (including intent, performance criteria, and a range of acceptable solutions suitable for Queensland).
- includes only those design elements of relevance to the particular type of residential development under consideration.
- references to related publications such as Queensland Streets and the Queensland Urban Drainage Manual.

Queensland Streets (IMEAQ 1996) provides the basis for a uniform standard of residential streetworks design, with detailed design criteria in accordance with AMCORD principles.

The 'Queensland Urban Drainage Manual' (DPI et al, 1993) as well as considering environmental and legal aspects, provides planning guidelines and design processes and methods for urban stormwater drainage works in Queensland.

Each section has been prepared acknowledging that:

- certain design elements are essential to be complied with to achieve a satisfactory design solution;
- some design elements may only apply to certain parts of a local government area or may only apply to specific development applications; and
- other design elements exist which will result in a more highly sophisticated level of performance and have been included for their education role.

This has been achieved by the following organisation of the Design Elements:

General

Compliance with these elements is required to achieve an acceptable level of performance in planning, design, and development of residential projects.

Site Specific

Compliance with these elements is only required in special circumstances, where sufficient community interest warrants detailed consideration of them and/or a sophisticated residential planning, design, and development outcome is desired. These elements would usually be specified in specialised documents produced through community consultation, such as in conditions of rezoning and/or town planning consent, and/or provisions of a Development Control Plan.

Alternatively, developers might wish to voluntarily comply with these elements to dispel perceived community concerns.

Advisory

Advisory design elements have also been included as an appendix. Compliance with these design elements is not required to achieve compliance with the Residential Design Guidelines. They have been included as they are considered to be 'desirable' design elements from the perspective of creating good design outcomes. However, due to the subjective nature of the design elements and the difficulty in specifying acceptable solutions, it is not considered appropriate that these design elements be required to be complied with to achieve an approval. Consequently, the decision to apply these design elements is to remain with the designer, rather than the approving authority.

1.1 Application of Design Guidelines

The Attached Housing Guidelines apply to development which:

- relates to one overall allotment previously created;
- involves the construction of one or more groups of attached dwellings; and
- no prior plan of development has been created.

Where the development proposed relates to a number of attached housing allotments, with or without public road being created, the Integrated Development Guidelines apply.

These guidelines apply to all forms of low to medium rise housing including:

- duplexes;
- townhouses; and
- residential flats and units.

(For most duplex housing, parts of the design Elements on "Communal Open Space and Landscaping", and "Site Facilities" will have little relevance).

High rise development in excess of four storeys (ie: 3 storeys over carparking) and requiring lifts are not covered by these Guidelines.

1.2 The Performance Approach

The Queensland Residential Design Guidelines adopts a performance-based system of control. Instead of specifying prescriptive standards, it focuses on matters to be addressed (called Performance Criteria) in order to achieve a desired outcome (called Intent).

Such a performance-based system centred on objectives and desired outcomes, offers an opportunity for diversity and choice, and provides flexibility to respond to market needs and preferences, and changes in approaches and technology.

Performance-based regulation is enhanced if examples of ways in which the desired result can be achieved are indicated. Acceptable Solutions are provided as examples of what is considered acceptable, while not precluding other options.

The Acceptable Solutions illustrate ONE WAY only of meeting the associated Performance Criteria. The acceptability of other solutions would need to be demonstrated. This may be achieved with reference to built examples, plans and/or illustrations representing contemporary best practice in residential planning, design and development.

Each Design Element has a consistent format (refer figure 1). A concise statement of intent is at the top of the page (1). The left column sets the Performance Criteria (2) and the right column Acceptable Solutions (3) relates to the relevant Performance Criteria.

The Guidelines do not repeat the explanatory and background material included in AMCORD for each Design Element. This material however, should be referenced where alternative solutions are proposed, or where clarity is required in relation to the source and/or intention of the Performance Criteria.

1 Intent

The Intent outlines the aim of the Design Element and reflects identified planning and policy requirements.

In complying with the Intent, an applicant must conform to all relevant Performance Criteria. Where Acceptable Solutions have been documented to cover specific Performance Criteria, designers can use these in satisfaction of the Performance Criteria.

2 Performance Criteria

Performance Criteria are general statements of the means of achieving the Intent. They are not meant to be limiting in nature. Instead, they provide designers and developers with an opportunity to develop a variety of design responses.

Not all Performance Criteria will be applicable to every development. In submitting a proposal for approval, the designer and developer must indicate those criteria not relevant to their particular development.

In other circumstances, some performance criteria may be found to conflict with other performance criteria. In these instances, "trade-offs" may need to be considered as part of the design and approval process in arriving at an acceptable solution.

1.2 The Performance Approach (continued)

3 Acceptable Solutions

Acceptable Solutions are provided as examples of what may enable the achievement of the Performance Criteria. They should not be interpreted as an alternative prescriptive form of regulation, nor should they preclude other solutions.

Acceptable solutions may not be provided for all Performance Criteria. In those instances, solutions specific for each circumstance will need to be developed by the designer.

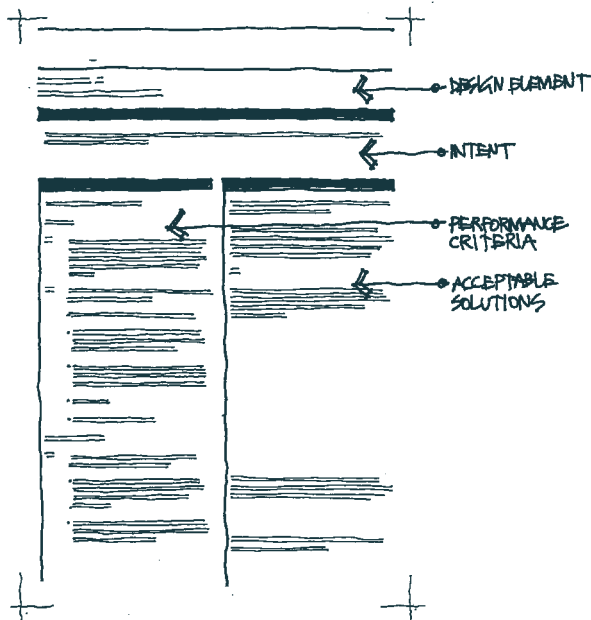

Figure 1: The layout of a typical page for a Design Element

1.3 Site Analysis

A detailed and comprehensive site analysis is the foundation of any good design and should be carried out if the intent of these guidelines to be achieved.

Specifically, the objective of the site analysis is to ensure that a coherent site layout and design is achieved which:

- identifies the constraints of the site;
- highlights the site's opportunities; and
- shows the important aspects of the surrounding environment.

The site analysis plan highlights a number of aspects which can be otherwise readily overlooked, namely:

- the need for retaining walls and the impact on adjoining properties' amenity;
- redirection of overland flow paths; and
- clashes of services and building works.

The submission of a site analysis plan will assist in the development assessment process and is needed should more innovative design solutions be proposed.

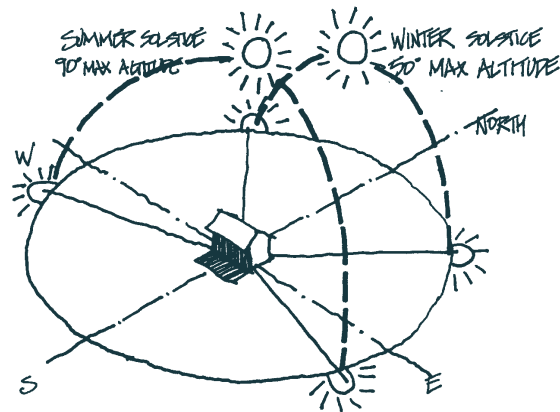

Figure 2: Solar path diagram

COMPONENTS OF A SITE ANALYSIS

Depending on the type of development, its scale and location, the components of the Site Analysis may need to include some or all of the following:

THE SITE

- Site dimensions and site area
- Spot levels, contours and north point
- Easements for drainage and services
- Location of existing vegetation, including the height and spread of established trees
- Location of buildings and other structures
- Heritage features including any archaeological features
- Orientation, significant noise sources and micro climates (eg: keeping potential for breezes)
- Views to and from the site
- Pedestrian and vehicle access
- Identification of previous use and any contaminated soils or, where practicable, filled areas
- Location of fences, boundaries and any other notable features (natural or historical)
- Prevailing winds
- Natural drainage
- Overshadowing of the site by neighbouring structures

The site analysis should indicate the proposed arrangement of buildings and spaces on the site.

THE SURROUNDS

- The location, height and use of neighbouring buildings (including location of any facing doors and windows) and out-buildings
- The built form and character of adjacent and nearby development, including characteristic fencing and garden styles
- Abutting secluded private open spaces and living room windows which have outlooks towards the site, particularly those within 9m of the site boundaries.
- The heritage significance of surrounding buildings and landscape

- Characteristics of any adjacent public open space
- Location and height of walls built to the site's boundary
- Views and solar access enjoyed by adjacent residents
- Major trees on adjacent properties, particularly those within 9m of the subject site
- Street-frontage features such as poles, street trees, kerb crossovers, bus stops and other services
- Directions and distances to local shops, schools, public transport, parks and community facilities
- The difference in levels between the subject land and adjacent properties at their boundaries
- Sources of nuisance such as flight paths, noisy roads or industries and the like.

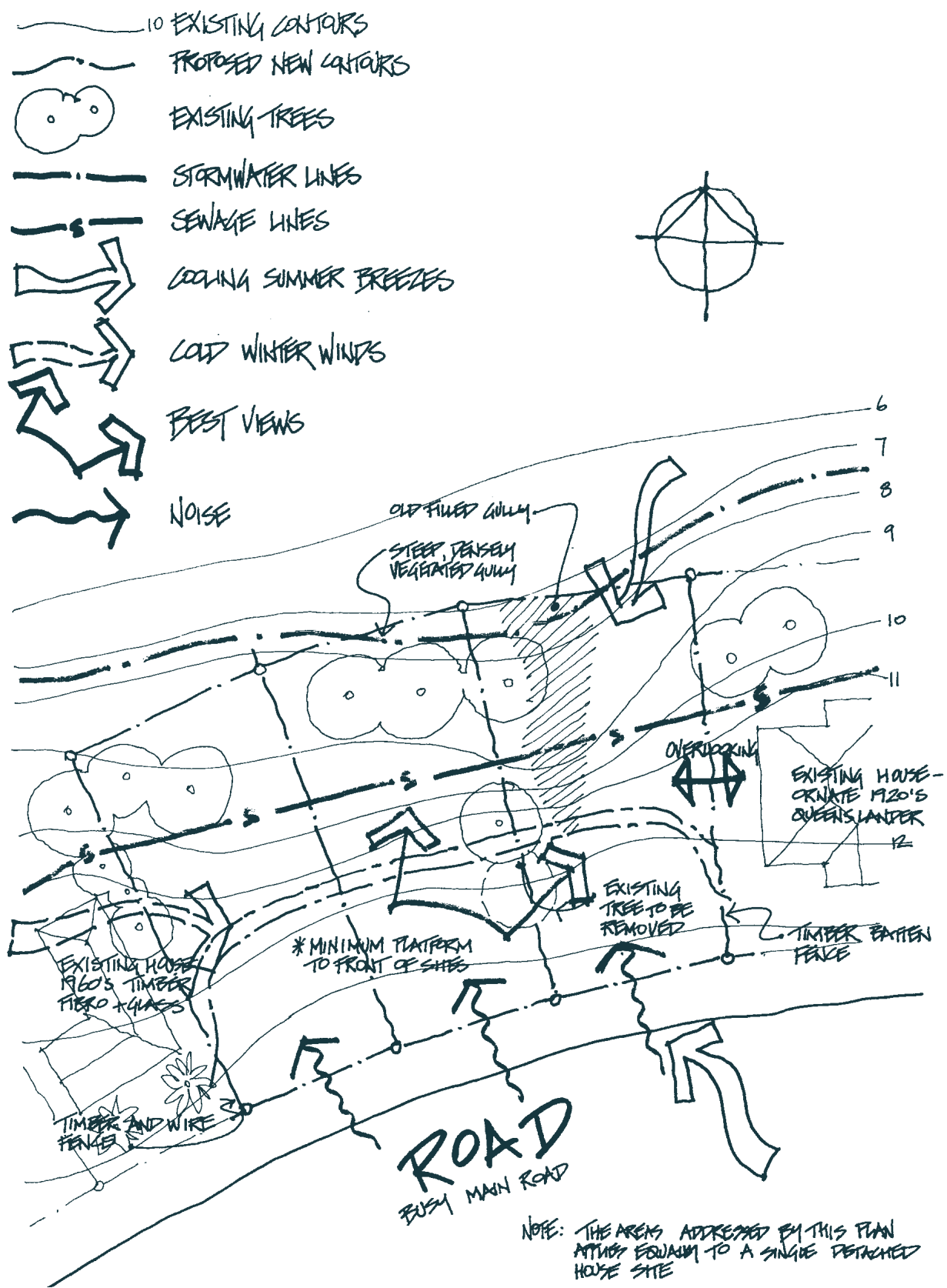

Figure 3: Typical site analysis plan

ELEMENT A1

Street Setbacks

INTENT

To setback dwellings and garages/carports from the street to provide adequate space for landscape or open space, visual and acoustic privacy and vehicle parking.

PERFORMANCE CRITERIA

The intent may be achieved where:

- P1** The setback of dwellings makes efficient use of the site, provides amenity for residents and allows space for the required vehicle parking.

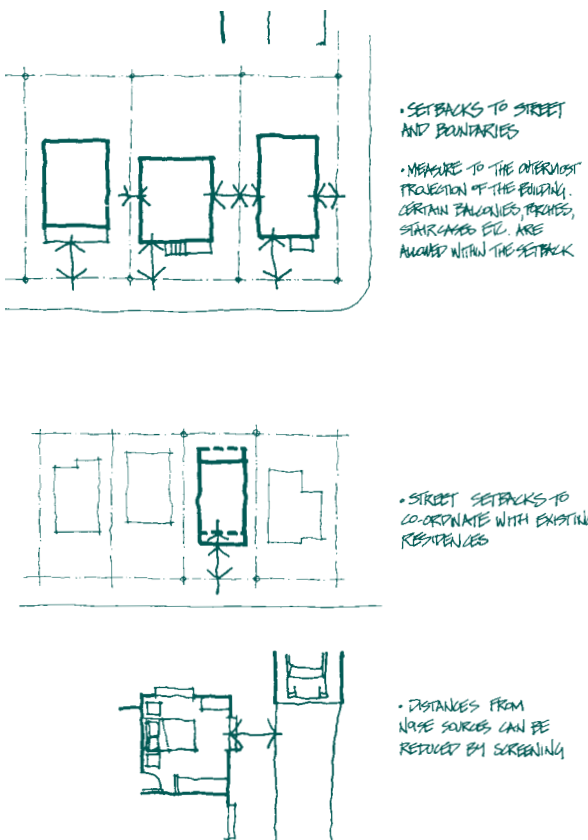

Figure 4: Street / noise source setbacks

ACCEPTABLE SOLUTIONS

The Acceptable Solutions illustrate ONE WAY of meeting the associated Performance Criteria.

- A1.1** A Streetscape Concept Plan and/or Landscape Plan is submitted that demonstrates how the Performance Criteria are met.

OR

- A1.2** In areas being urbanised or newly-developed areas, setbacks (inclusive of any verandah, porch etc) from the street boundary should be as follows:

TABLE 1: Street setbacks in new areas¹

Street type	Minimum frontage setback (m)	Minimum side setback to corner street (m)
Access Place and Access Street	3.0	1.0
Collector Street	4.0	2.0

¹ The setback may be averaged, providing no part of the building is setback less than 2m.

OR

- A1.3** In established areas where the setback of an adjacent building is greater than 3m, the minimum street setback of infill development is to be the lesser of:

- the setback specified in the Standard Building Law; and
- the same distance as one or the other of the adjoining buildings, provided the difference between the setbacks of the two adjoining buildings is less than or equal to 2m; or
- the average of the setbacks of the adjoining dwellings, if the difference between the setbacks of the adjoining buildings is greater than 2m.

ELEMENT A 1

Street Setbacks continued

PERFORMANCE CRITERIA

ACCEPTABLE SOLUTIONS

- A1.4** In established areas where the setbacks of adjacent buildings are 0–3m, infill development is to be setback the same distance as one or the other of the adjoining dwellings.
- A1.5** Setback of buildings in significant urban conservation and heritage streetscapes shall generally match with that of adjacent development unless an alternative policy has been developed for that street.
- A1.6** In community title developments, walls of dwellings incorporating a habitable room to be setback a minimum of 1.5m from shared driveways, communal streets and visitor carparks. This setback may be reduced if suitable privacy screening and/or acoustic treatment to the dwelling walls is provided.
- A1.7** Single garages/carports associated with dwellings for which more than one on-site parking space is required are to be setback from the public street frontage a minimum of 5.5m if tandem parking is proposed.
- A1.8** Double garages/carports are setback from a corner or secondary street frontage to not less than half the setback to the street of any existing adjacent dwelling that faces the secondary street, provided that the setback is not less than that of the associated dwelling.

ELEMENT A 2

Building Envelope and Siting

INTENT

To enable flexibility in building siting while protecting reasonable neighbour amenity expectations, maintaining appropriate residential character and visual bulk, and providing adequate daylight to dwellings and sunlight to private open space.

PERFORMANCE CRITERIA

Building Envelope Setbacks

- P1** Setbacks are progressively increased as wall height increases to reduce bulk and overshadowing while maintaining adequate daylight and sunlight.
- P2** Building siting and height is related to land form, with minimal cut and fill.
- P3** Building bulk is generally distributed to reduce impact on neighbours and on the public street.
- P4** Building heights are similar to those in the public streetscape, with taller buildings sited so as to minimise adverse impacts on neighbours and on the streetscape.
- P5** Building forms enable a sharing of any longer views with neighbours.
- P6** Building to the boundary maximises privacy for neighbouring dwellings and their private open space.

ACCEPTABLE SOLUTIONS

The Acceptable Solutions illustrate ONE WAY of meeting the associated Performance Criteria.

Building Envelope and Setbacks

(in partial satisfaction of P1 to P5)

- A1.1** Where walls are not built to the boundary, side and rear setbacks shall comply with the Standard Building Law – Part 9.

ELEMENT A 2

Building Envelope and Siting continued

PERFORMANCE CRITERIA

- P7** Boundary walls are limited in length and height to minimise the impact on neighbours.

ACCEPTABLE SOLUTIONS

- A7.1** Walls built to side boundaries have:
- an average height of 3.0m
 - a maximum height of 3.5m, unless they:
 - abut a higher existing or simultaneously constructed wall;
 - are in accord with an approved building envelope plan;
 - abut a side or rear lane (in which case the maximum height shall be 5.5m).
- AND
- A7.2** Where there are no existing boundary walls, the maximum boundary wall length is 15 metres.
- OR
- A7.3** The length of new boundary walls matches the length of existing boundary walls.
- OR
- A7.4** In areas where it has been determined to provide for an increase in development built to boundaries, the length of new boundary walls is limited to:
- 50% of the length of the adjacent side boundary;
- OR
- the length of existing boundary walls plus 50% of the length of the remaining boundary.
- OR
- A7.5** In areas characterised by buildings with boundary walls extending for the full length of adjacent side street or rear lane boundaries, new boundary walls can extend for the full length of adjacent side street or rear lane boundaries.
- OR

ELEMENT A 2

Building Envelope and Siting continued

PERFORMANCE CRITERIA

- P8** Buildings are sited and designed to provide adequate daylight to habitable rooms.

ACCEPTABLE SOLUTIONS

Daylight and Sunlight

- A7.6** Where slope, retaining walls, fences and/or dwelling design would result in the effective height of a boundary wall being less than 2m on the adjacent property boundary, the new boundary wall can extend the full length of the side or rear boundary less any front boundary setback distance.
- A8.1** Habitable rooms in dwellings have windows in compliance with the BCA, sufficient to meet light requirements.

ELEMENT A 3

Storm Drainage

INTENT

To provide storm drainage systems which adequately protect dwellings at an acceptable level of risk and in a cost-effective manner, in terms of initial cost and maintenance, and which contribute positively to environmental enhancement of catchment areas.

PERFORMANCE CRITERIA

The intent may be achieved where:

Roof Drainage

P1 The roof drainage system has the capacity to control stormwater flows under normal operating conditions for the relevant design storm:

- which prevents the flow of stormwater from the guttering into the dwelling;
- which does not concentrate or re-direct stormwater onto adjoining properties.

P2 Design of the roof and site drainage system is such that it can be economically maintained with a reduced risk of blockages.

Site Drainage

P3 The site drainage system has the capacity to control surface stormwater flows from the site and any excess flows from upstream properties to prevent stormwater flows from entering the dwelling in the design event.

P4 The ground-floor level of the dwelling is located above the site surface level to an extent which prevents entry of stormwater flows into the dwelling in accordance with an acceptable level of risk.

P5 The site drainage system minimises undesirable ponding for a prolonged period.

P6 Design of the site drainage system provides for on-site infiltration if soil conditions are suitable.

P7 Adequate provision is made for measures during construction to ensure that the land form is stabilised and erosion is controlled.

ACCEPTABLE SOLUTIONS

The Acceptable Solutions illustrate ONE WAY of meeting the associated Performance Criteria.

A1 The roof drainage system is designed for a rainfall intensity derived for the area in which the design is proposed based on ARI = 20 years, 5 minutes duration.

A2 Leaf guards fitted to guttering at downpipes. Clean out points provided on underground pipe systems.

A3.1 Where the topography of the site makes it necessary to discharge stormwater run-off to the rear of the site, the run-off from all directly connected impervious areas (roof and paved areas) shall be to an inter-allotment drainage system (to the requirements of QUDM);

AND

A3.2 The site slopes away from the dwelling (50mm at 1000mm from dwelling).

A4 Compliance with the BCA requirements for minimum floor heights.

A5 Provide for no area to pond to a depth greater than 50mm within one hour following rainfall.

A6 If soil conditions are suitable, soakage chamber installed within property with overflow via inter-allotment drainage system.

A7 Site erosion prevention details are provided as per industry code of practice.

ELEMENT A 3

Storm Drainage continued

PERFORMANCE CRITERIA

Internal Road and Pathway and Open Space Drainage

Major system

- P8** The major storm drainage system has the capacity to safely convey stormwater flows result from the relevant design storm under normal operating conditions.
- P9** The major system has the capacity to convey safely, but without significant property damage, stormwater flows resulting from more extreme events than its design storm.
- P10** Ground-floor levels of proposed dwellings can be located above the design flood level to provide protection of property in accordance with the accepted level of risk.
- P11** Floodways are developed such that there is a low risk of property damage.
- P12** The major system is designed to ensure that there are no flow paths which would increase risk to public safety and property.
- P13** Community benefit is maximised through the retention of natural streams and vegetation wherever practicable, the incorporation of sports grounds and other less flood-sensitive land uses into the drainage corridor and the placement of detention and retention basins for amenity and function.

Minor system

- P14** The minor storm drainage system has the capacity to control stormwater flows under normal operating conditions for the relevant design storm without blockage.
- P15** Drainage networks are well-defined to ensure there are no hidden flow paths which could reduce their capacity to convey design flows.
- P16** The minor system design minimises undesirable ponding for a prolonged period resulting from the relevant design storm.

ACCEPTABLE SOLUTIONS

Major system

(in relation to P8 to P13)

- A8** The design and construction of the major storm drainage system are in accordance with a plan of development and the requirements of the relevant authorities.

OR

Development conforms with the provisions of Queensland Urban Drainage Manual except that:

- a) the major system has the capacity to safely convey stormwater flows under normal operating conditions and partial minor system blockage for ARI = 50 years.
- b) Flows within the street are limited in depth and velocity by the formula

$$d_g V \text{ is } < \text{or} = 0.9 \text{ m}^2/\text{S}$$

for longitudinal flow

$$d_g V \text{ is } < \text{or} = 0.6 \text{ m}^2/\text{S}$$

for cross flow where a vehicle is likely to be washed off the roadway into the drainage system

$$d_g V \text{ is } < \text{or} = 0.4 \text{ m}^2/\text{S}$$

for cross flow where a pedestrian is likely to be washed into the drainage system

[where d_g = kerbside flowdepth (m)]

ELEMENT A 3

Storm Drainage continued

PERFORMANCE CRITERIA

Minor system (continued)

- P17** The design of the minor system takes full account of existing downstream systems.
- P18** The minor system design allows for the safe passage of vehicles at reduced speed on streets which have been affected by runoff from the relevant design storm.
- P19** The minor system is accessible and easily maintained.
- P20** Where a portion of the minor system lies within a site, access is available for maintenance.
- P21** The selection of materials used for the construction of the minor system is based on their suitability, durability, maintainability and cost-effectiveness.

ACCEPTABLE SOLUTIONS

Minor system

(in relation to P14 to P21)

- A14** The design and construction of the minor system is in accordance with a plan of development and the requirements of the relevant authorities.

OR

(in relation to P14 to P17)

Development conforms with the provisions of the Queensland Urban Drainage Manual.

ELEMENT A 4

On-site Carparking and Access

INTENT

To ensure adequate provision of secure and accessible on-site parking for residents and visitors.

PERFORMANCE CRITERIA

The intent may be achieved where:

Parking provision

P1 Carparking is provided according to projected needs which are determined by:

- availability of public transport;
- the availability of on-street carparking;
- locations of non-residential uses such as schools and local shops;
- the possible demand for carparking space from adjoining localities;
- the occasional need for overflow parking;
- the carparking requirements of people of differing socio-economic status, age, cultural background and differing stages of family life cycle.

Layout and Design

P2 Carparking facilities are designed and located to:

- conveniently and safely serve users, including pedestrians, cyclists and vehicles;
- enable efficient use of car spaces and accessways, including adequate manoeuvrability for vehicles between the street and the lot;
- fit in with any adopted street network hierarchy and objectives of the hierarchy, and with any related local traffic management plans;
- be cost-effective;
- achieve relevant streetscape objectives.

ACCEPTABLE SOLUTIONS

The Acceptable Solutions illustrate ONE WAY of meeting the associated Performance Criteria.

Parking provision

A1 The number of spaces provided is to comply with the following:

Dwelling Unit size or No. of bedrooms	Average spaces per dwelling*	
	A	B
Small or 1 bedroom < 75 m ²	0.75	1.00
Medium or 2 bedroom 75 m ² – 110 m ²	1.00	1.50
Large or 3 + bedroom > 110 m ²	1.25	2.00
Add for visitors per dwelling	0.25	0.25

* Round up to nearest whole number

Dwelling location
A < 400m from railway station, or bus stop
B any other circumstances.

Note: Development plans may identify areas in which a lesser provision may be appropriate, based on housing density, accessibility to public transport and employment areas, other factors such as these.

ELEMENT A 4

On-site Carparking and Access continued

PERFORMANCE CRITERIA

Layout and Design (continued)

- P3** Carparking areas and accessways are designed, surfaced and sloped to facilitate stormwater infiltration on-site.
- P4** Open carparking areas and accessways are suitably landscaped to enhance amenity while providing for security needs of residents and visitors.

Construction

The intent may be achieved where:

- P5** The pavement, edging and landscaping support the specified functions and amenity of the street.
- P6** The pavement edge:
- controls vehicle movements by delineating the carriageway for all users;
 - assists in reducing stormwater run-off into the reticulated system, by conveying stormwater to a desired outlet or by providing for infiltration into subsoil;
 - provides for people with disabilities, by allowing safe passage of wheelchairs and other mobility aids.
- P7** Street pavement surfaces are well designed and durable enough to carry wheel loads of travelling and parked vehicles; ensure the safe passage of vehicles, pedestrians and cyclists; the discharge of rainfall, and the preservation of all-weather access; and allow for reasonable travel comfort.
- P8** Consistent with the previous Performance Criteria, street construction and whole-of-life-cycle costs are minimised.

ACCEPTABLE SOLUTIONS

Design

- A2.1** The dimensions of car spaces and access comply with the local planning scheme, or a Plan of Development.
- A2.2** Accessways and driveways are designed to enable vehicles (the 98 percentile vehicle) to enter the designated parking space in a single turning movement, and leave the space in no more than two turning movements.
- A2.3** Access(es) of internal roadways to the public street system are located and designed in accordance with Queensland Streets, and any requirements of the Local Government (and/or the Department of Main Roads on a declared road).
- A2.4** Internal roadways are located to provide convenient connection between the public street, and all internal parking areas and service areas within the site.
- A2.5** Cul-de-sac roadways are avoided as far as possible.
- A2.6** Vehicles can turn within the site, to both enter from and exit to the public street in the forward direction.
- A2.7** The carriageway cross-section and geometry of roadways are in accordance with Queensland Streets recommendations for an Access Place or an Access Street as appropriate.
- A2.8** The widths and cross-section of roadway verges are sufficient to provide adequately for pedestrian footpaths (where required), utility services, and landscaping for visual amenity.
- A2.9** General minimum verge widths are 1.5m where no constructed footpath is required, or 2.5m where a footpath is required.
- A2.10** A separate constructed pedestrian footpath is provided where the "traffic catchment" of the roadway exceeds 40 dwelling units.

ELEMENT A 4

On-site Carparking and Access continued

PERFORMANCE CRITERIA

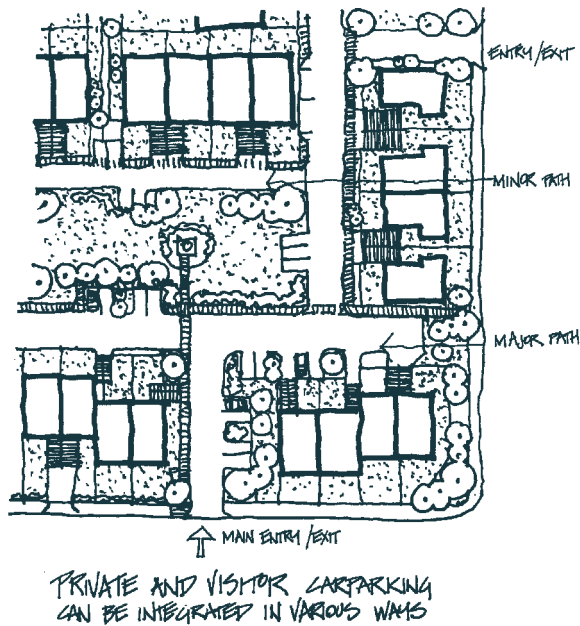

Figure 5: Integrated private and visitor carparking

ACCEPTABLE SOLUTIONS

A2.11 Separate footpaths are designed in accordance with Queensland Streets .

A2.12 Vehicle turning areas are provided at the end of cul-de-sac roadways, generally in accordance with the recommendations of Queensland Streets, but with geometry modified for the relevant refuse collection vehicle; except that for minor roadways, with maximum length 30m and providing access to a maximum of four units, the design vehicle may be a B99 car.

(in partial satisfaction of P3)

A3 Open carparking spaces are surfaced with materials that provide for stormwater infiltration.

A5 Pavement and landscape materials are used, where appropriate, to distinguish different street functions.

(in partial satisfaction of P6 to P8)

A6 Pavement edges at locations where pedestrians are encouraged to cross, are constructed for wheelchair access and to assist sight-impaired people in accordance with AS1428 Pt1 and Pt4.

A8.1 Flexible pavement construction is based on the ARRB residential street pavement design method using equivalent standard axle loadings and a 20-year design life (ARRB, 1989).

AND

A8.2 Concrete pavement construction is based on the Cement and Concrete Association of Australia's design table, and interlocking block pavement construction is based on the ARRB interlocking block pavement design method.

A8.3 Kerb and channel profiles accord with Australian Standard 2876-1987 or as specified by the relevant authorities.

ELEMENT A 5

Private Open Space

INTENT

To ensure that the private open space provided for dwelling units is clearly defined, usable and meets user requirements for privacy, access, outdoor activities and landscaping.

PERFORMANCE CRITERIA

The intent may be achieved where:

- P1** Private open space is clearly defined for private use.
- P2** Private open space areas are of dimensions to suit the projected requirements of the dwelling occupants, and to accommodate some outdoor recreational needs as well as providing space for service functions.
- P3** Part of the private open space is capable of serving as an extension of the dwelling unit for relaxation, dining, entertainment, recreation and children's play, and is accessible from a main living area of the dwelling.

ACCEPTABLE SOLUTIONS

The Acceptable Solutions illustrate ONE WAY of meeting the associated Performance Criteria.

(in partial satisfaction of P1 to P3)

- A1.1** For developments with a site density of 40 dwellings per ha or less, private open space for the dwelling unit comprises:

(a) At-ground level:

- total minimum area of 20% of the site area (or average site area per dwelling for multi-dwelling developments), with a minimum dimension of 3.0m;
- one part with an area of 25m² with a minimum dimension of 4m and directly accessible from a living area of the dwelling;
- a maximum gradient of 1 in 10;
- screening provided where necessary to ensure privacy to users of the open space.

Note: A balcony or deck may be utilized as private open space where site gradients are excessive.

(b) At above-ground level:

- a balcony or rooftop area conveniently accessible from a main living area of the dwelling, having a minimum area of 10m² with a minimum dimension of 2m (2.5m in hot-humid and hot-arid climates);
- adequate screening to protect the privacy of neighbours (refer to Appendix Element C3).

OR

ELEMENT A 5

Private Open Space continued

PERFORMANCE CRITERIA

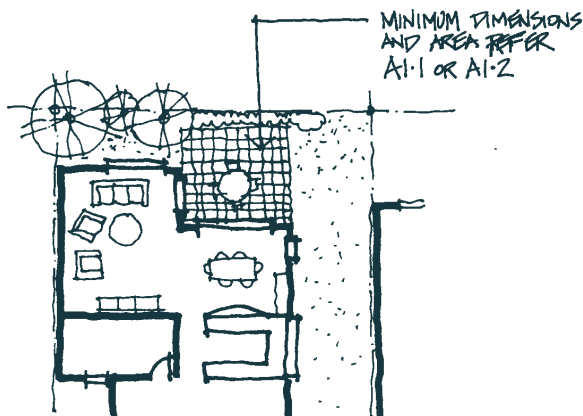

Figure 6: Small lot private open space

- P4** Location of private open space takes advantage of outlook and natural features of the site; reduces adverse impact of adjacent buildings on privacy and overshadowing; and addresses surveillance, privacy and security issues where private open space abuts public space.
- P5** Orientation of private open space helps to achieve comfortable year-round use.

ACCEPTABLE SOLUTIONS

A1.2 For developments with a site density of more than 40 dwellings per ha, private open space for the dwelling unit comprises:

(a) At-ground level:

- total minimum area of 35m² (minimum 20% of site area for site densities greater than 60 dwellings per ha);
- a minimum dimension of 2.5m;
- a maximum gradient of 1 in 10;
- one part with an area of 16m² with a minimum dimension of 4m and directly accessible from a living area of the dwelling;
- screening provided where necessary to ensure privacy to users of the open space.

Note: A balcony or deck may be utilized as private open space where site gradients are excessive.

(b) At above-ground level:

- adequate screening to protect the privacy of neighbours (refer to Appendix Element C3);
- a balcony or rooftop area directly connected to the dwelling, having a minimum area of 8m² with a minimum dimension of 2m (2.5m in hot-humid and hot-arid climates).

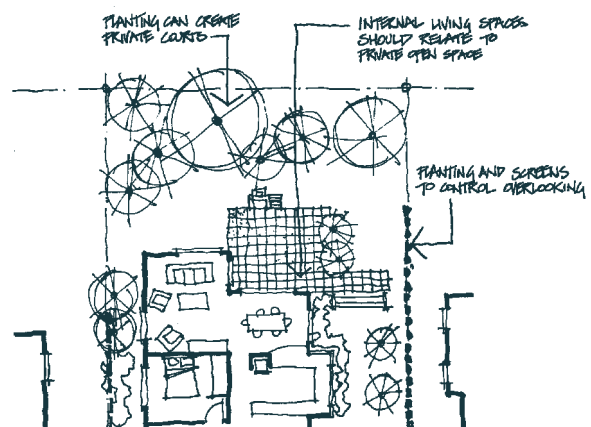

Figure 7: Private open space on larger lots

ELEMENT A 6

Communal Open Space and Landscaping

INTENT

To ensure that any communal space provided for dwelling units is clearly defined and usable, and helps create a pleasant, safe and attractive living environment.

PERFORMANCE CRITERIA

The intent may be achieved where:

- P1** Communal open space is designed according to projected user needs and is determined by: overall housing density; quality and extent of alternative private or nearby public open space; the need to distinguish communal open space clearly from private or public open space; type of activities envisaged; future maintenance and management requirements; the need to maintain the privacy of nearby dwellings; projected needs of children for outdoor play; the need for landscaping to enhance a sense of enclosure of communal open spaces, while allowing informal surveillance and meeting security needs; traffic implications; and hours of operation of communal facilities.
- P2** Unpaved or unsealed landscaped areas are maximised and are designed to facilitate on-site infiltration of stormwater run-off subject to soil/drainage conditions.
- P3** Major existing trees are retained wherever practicable through appropriate siting of dwellings and structures.
- P4** The landscape design specifies the location and species of trees, shrubs and ground cover in a way that:
- uses vegetation types and landscaping styles which blend the development into the streetscape;
 - does not adversely affect the structure of the proposed buildings;
 - contributes appropriate planting to streets fronted by the development;
 - considers personal safety, by ensuring good visibility along paths and driveways and avoiding shrubby landscaping near thoroughfares;

ACCEPTABLE SOLUTIONS

The Acceptable Solutions illustrate ONE WAY of meeting the associated Performance Criteria.

(in partial satisfaction of P1 to P8)

- A1** Landscaping shall be in accordance with an approved landscape plan for the site, certified by a qualified landscape architect or designer as meeting the Performance Criteria, and showing:
- the street reserve, carriageway, parking bays, footpaths, cycleway systems, street lighting and driveways;
 - existing vegetation and proposed general character of tree planting and landscape treatment (including proposed species and proposed means of ensuring the ongoing health and development of retained trees);
 - general arrangement of hard landscaping elements and major earth cuts, fills and mounding;
 - location and design of any communal recreation facilities, including methods of protecting the privacy of nearby dwellings;
 - clear delineation between communal and private areas of the site;
 - how informal surveillance of the communal open space can be achieved;
 - proposed irrigation and maintenance systems;
 - proposed lighting arrangement;
 - indicative treatment of any floodways and drainage lines, along with general information on fencing, access points, furniture and pavement style.

ELEMENT A 6

Communal Open Space and Landscaping continued

PERFORMANCE CRITERIA

- contributes to energy efficiency and amenity by providing substantial shade in summer, especially to west-facing windows and open carpark areas, and admitting winter sunlight to outdoor and indoor living areas (other than in the hot-humid and hot-arid climatic areas);
- improves privacy and minimises overlooking between dwelling units;
- minimises risk of damage to overhead and underground power lines and other services;
- provides adequate sight lines for vehicles and pedestrians, especially near street corners and intersections.

- P5** Paving is provided to driveways, walkways, entries, outdoor patios and in the vicinity of garbage bin enclosures, letter boxes and clothes lines. Such paving should be:
- semi-porous or graded (ie gravels) to maximise on-site infiltration of stormwater (if practicable);
 - in materials and colours which complement the development and alternative adjoining streetscapes;
 - finished in non-slip surfaces;
 - suitable for use by people dependent on walking frames and wheelchairs.
- P6** Planting will not obscure or obstruct dwelling unit entries, paths and streets in a way that reduces the actual or perceived personal safety and security of residents and other pedestrians.
- P7** Lighting is provided to pedestrian ways, dwelling unit entries, driveways and carparks to ensure a high level of safety and security for residents and visitors at night.
- P8** Requirements for maintenance meet the needs of the owners and proposed management of the landscaped area.

ACCEPTABLE SOLUTIONS

ELEMENT A 6

Communal Open Space and Landscaping *continued*

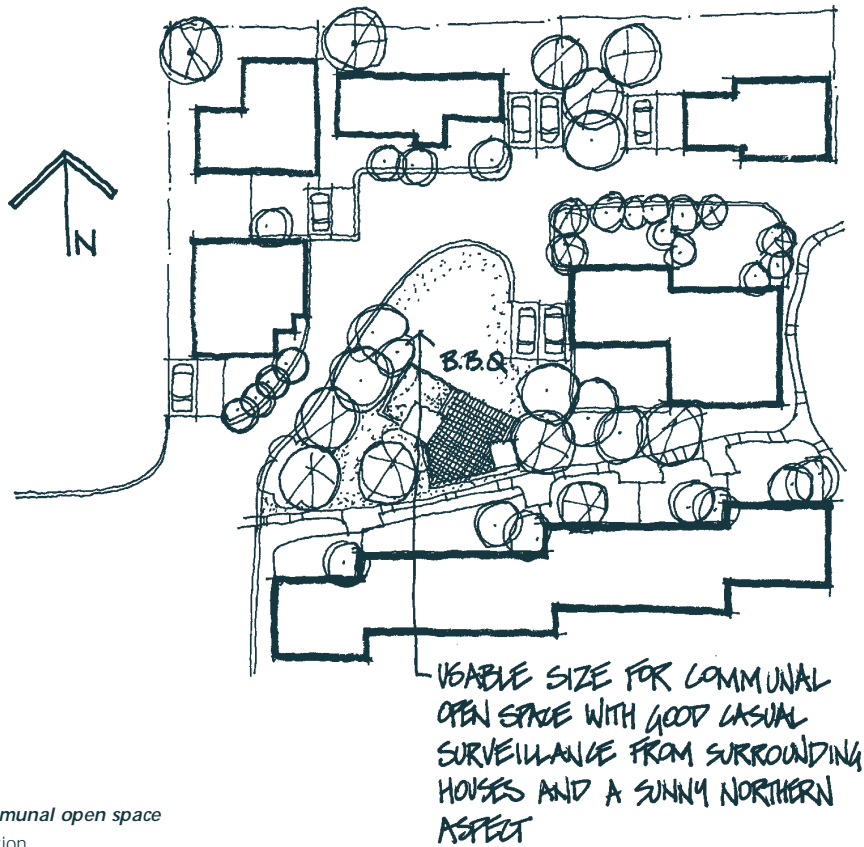

Figure 8: Communal open space Location

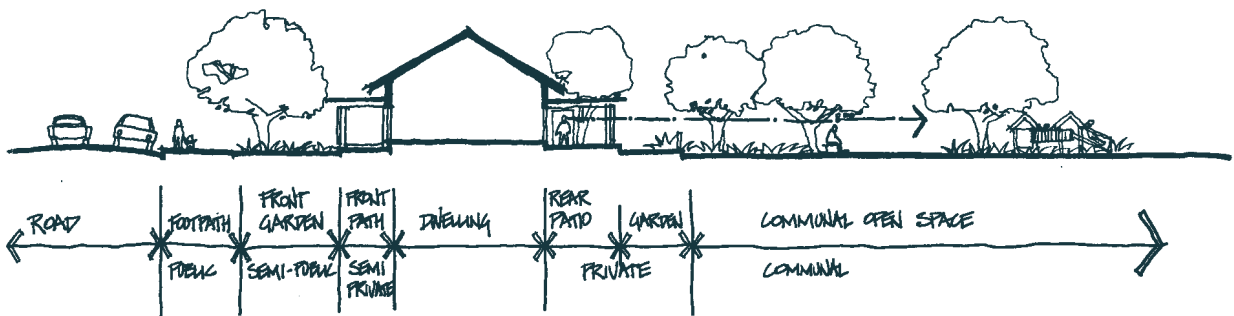

Figure 9: Communal open space Typical relationship with other spaces

ELEMENT A 7

Site Facilities

INTENT

To ensure that site facilities provide easy access to dwelling units are visually attractive, blend in with the development and street character, and require minimal maintenance.

PERFORMANCE CRITERIA

The intent may be achieved where:

- P1** Garbage bin areas, mail boxes and external storage facilities are sited and designed for attractive visual appearance and function, and complement the architecture and environs.
- P2** Garbage bin areas are designed for efficient and convenient use.
- P3** Site facilities enable collection of recyclable materials.
- P4** Site facilities include parking for bicycles according to projected user needs.
- P5** Mail boxes are located for convenient access by residents and deliverers, in a location visible from some dwellings on the site.
- P6** Dwelling units are provided with adequate storage areas and external clothes drying facilities.

ACCEPTABLE SOLUTIONS

The Acceptable Solutions illustrate ONE WAY of meeting the associated Performance Criteria.

(in partial satisfaction of P5)

- A5** Individual mail boxes* are located close to each ground-floor dwelling entry, or a mail box structure is located close to the major pedestrian entrance to the site.

**Australia Post mail delivery requirements apply.*
- A6.1** A space of 8m³ per dwelling is set aside exclusively for storage. This space may form part of a carport or garage.

AND
- A6.2** Open air, communal clothes drying facilities are easily accessible to all residents and visually screened from public streets and from communal streets and recreational areas.

ELEMENT A8

Site Works

INTENT

To ensure the site works for attached housing developments do not adversely impact on adjoining properties and are consistent with the design intent for the site.

PERFORMANCE CRITERIA

The intent may be achieved where:

- P1** Construction earthworks, particularly pad construction:
 - does not undermine, or result in earth spillage onto, adjoining properties;
 - does not redirect or concentrate stormwater flows onto adjoining properties;
 - makes allowances for utility services crossing or servicing the site;
 - makes allowances for future landscaping works to ensure satisfactory performance of the site storm drainage system.
- P2** The site works are undertaken so that the tracking of earth and other materials onto the public road way during the construction of the earthworks or the dwelling is minimised.
- P3** The site works are undertaken in such a manner as to ensure that there is no detriment by way of erosion, earth slippage or other hazard to adjoining properties during construction or in the event of building construction delay.

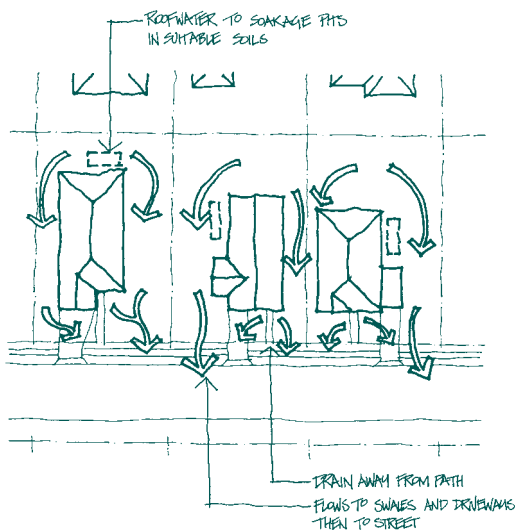

Figure 10: Site drainage methods

ACCEPTABLE SOLUTIONS

The Acceptable Solutions illustrate ONE WAY of meeting the associated Performance Criteria.

(in partial satisfaction of P1 to P3)

- A1** The submission of a Site Works Plan (or inclusion on the dwelling Site Plan) which demonstrates how the Performance Criteria are met showing:
 - details of all cut and fill showing finished levels, proposed methods of retaining cut and fill material;
 - site drainage paths after earthworks and allowance for landscaping; and
 - location of all services and their levels in relation to finished earthworks levels.

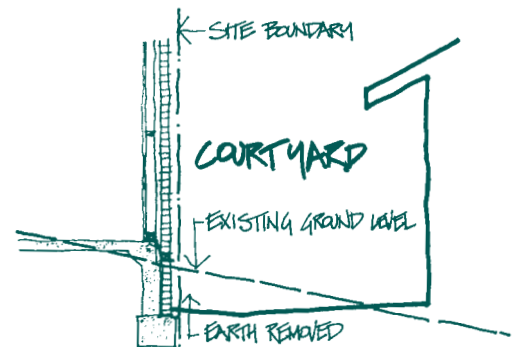

Figure 11: Desirable built to boundary detail
Low side of lot

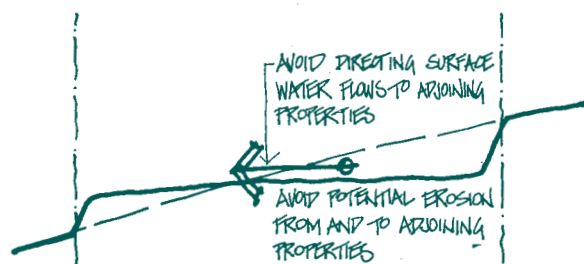

Figure 12: Earthworks site section

ELEMENT A8

Site Works *continued*

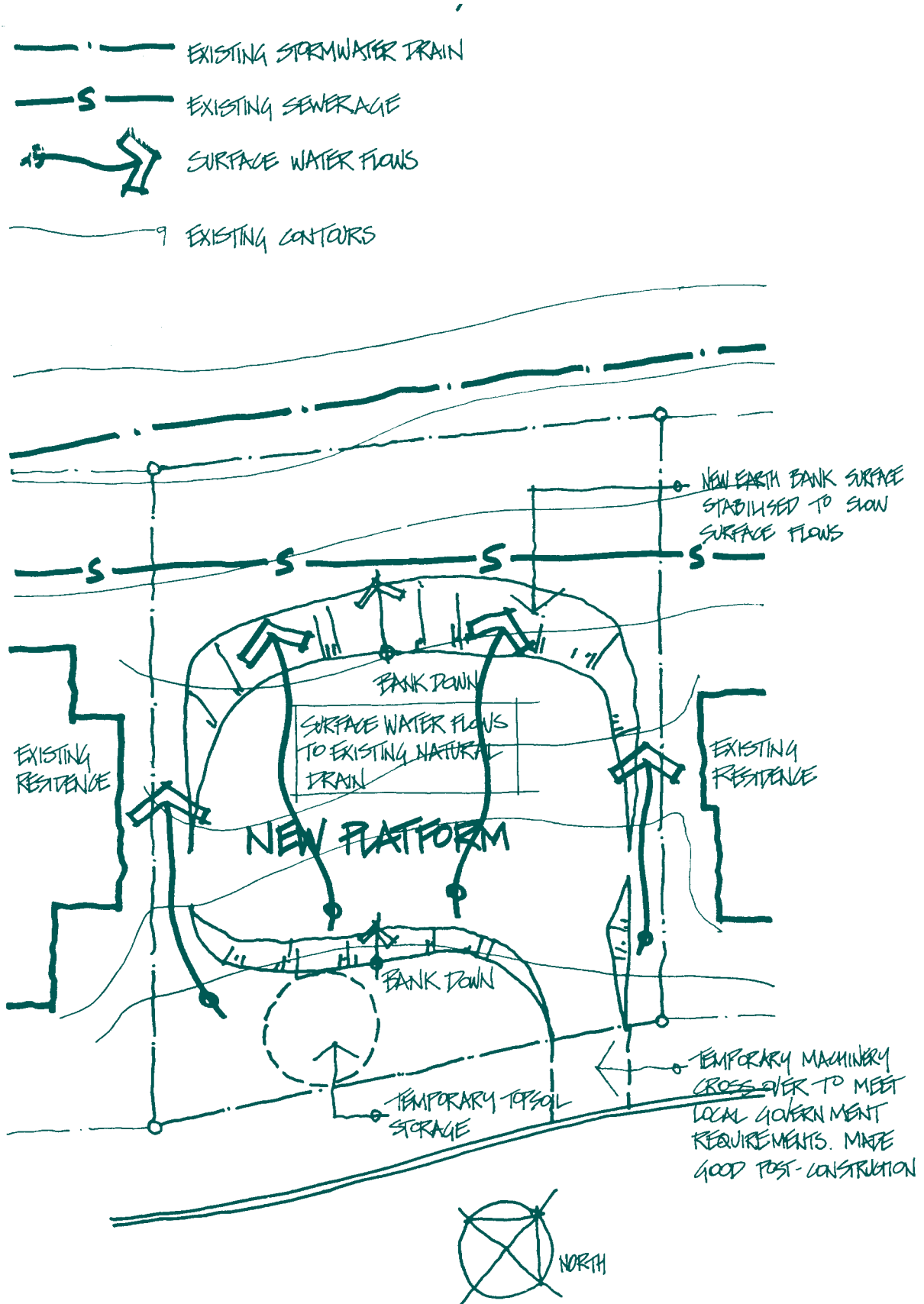

Figure 13: Typical site works plan

ELEMENT B1

Streetscape and Landscape

INTENT

To provide attractive streetscapes that reinforce the functions of a street, enhance the amenity of buildings, and are sensitive to the built form, landscape and environmental conditions of the locality.

PERFORMANCE CRITERIA

The intent may be achieved where:

P1 The street, building and landscape design achieves:

- the creation of attractive residential environments with clear character and identity;
- respect for identified existing streetscapes in established areas;
- appropriate streetscapes in areas where desired future urban character has been defined;
- the infiltration of stormwater run-off wherever practicable (subject to climatic, soils and urban character criteria);
- provision for appropriate street tree planting taking into account the image and role of the street, solar access requirements, soils, selection of appropriate species, and services;
- use of such features of the site as views, vistas, existing vegetation and landmarks.

P2 The design of the landscape in public and communal streets:

- defines a theme for new streets, or complements existing streetscapes and integrates with new development;
- is sensitive to site attributes;
- complements the functions of the street;
- reinforces desired traffic speed and behaviour;
- is of an appropriate scale relative to both the street reserve width and the building bulk;
- promotes safety and casual street surveillance;
- improves privacy and minimises unwanted overlooking;
- incorporates existing vegetation, where possible;

ACCEPTABLE SOLUTIONS

The Acceptable Solutions illustrate ONE WAY of meeting the associated Performance Criteria:

(in relation to P1 and P2)

A1.1 A Streetscape Concept Plan* is submitted that demonstrates how the Performance Criteria are met, showing:

- the street reserve and indicative locations of the carriageway, parking bays, footpaths, cycleway systems, speed control devices and, where practicable, driveways, bus stops, street lighting and substations;
- location of existing vegetation to be removed or conserved;
- location, species and general character of tree planting and hard and soft landscape treatment;
- location and indicative treatment of building form (eg setbacks, front elevation, garage/carport location and design, and front garden treatments) and street furniture.

AND

A1.2 For infill housing that abuts an existing public street, information should be submitted that demonstrates how the development fits in with an existing attractive streetscape or any statement of future urban character for that area.

* This plan may form part of or include a landscape plan. The need to complete such a plan will depend on local implementation requirements.

ELEMENT B1

Streetscape and Landscape continued

PERFORMANCE CRITERIA

- appropriately accounts for streetscapes and landscapes of heritage significance;
- assists in microclimate management;
- maximises absorptive landscaped areas for on-site infiltration of stormwater where appropriate;
- integrates and forms linkages with parks, reserves and transport corridors;
- enhances opportunities for pedestrian comfort;
- achieves lines of sight for pedestrians, cyclists and vehicles;
- provides adequate lighting for pedestrian and vehicle safety;
- provides attractive and coordinated street furniture and facilities to meet user needs;
- satisfies maintenance and utility requirements and minimises the visual impact of above-ground utilities.

ACCEPTABLE SOLUTIONS

(in relation to P1 and P2)

- A1.3** Landscaping is in accordance with the approved landscape strategy for the area. Compliance with this requirement is achieved by submission of a plan meeting the Performance Criteria, and showing:
- boundaries and areas of communal open space including sites for specific recreational uses;
 - existing vegetation and proposed general character of landscape treatment;
 - general arrangement of hard landscaping elements and major earth cuts, fills and mounding; and
 - indicative treatment of floodways, drainage lines and any major boundary with non-residential land, along with general information on fencing, access points, furniture, pavement style, and treatment of the verge including any associated parking or drainage requirements.

ELEMENT B1

Streetscape and Landscape *continued*

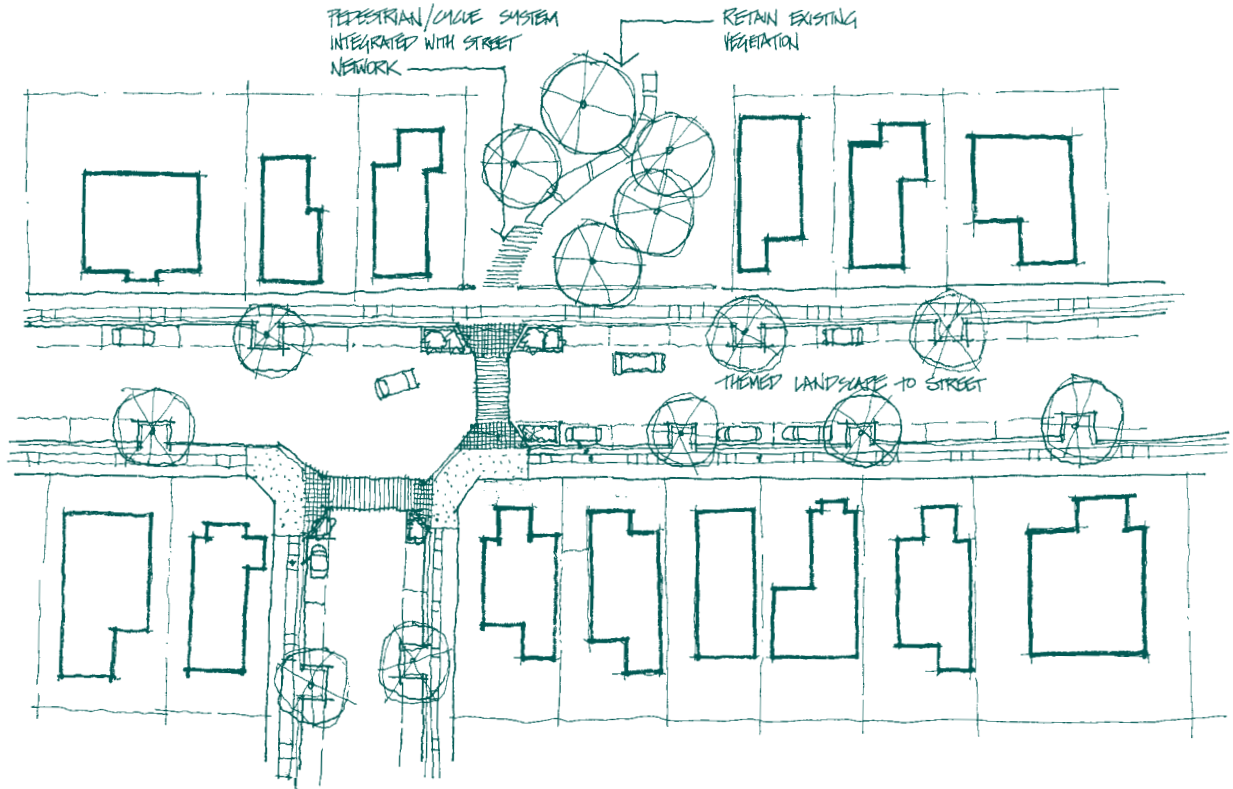

Figure 14: Streetscape concept plan

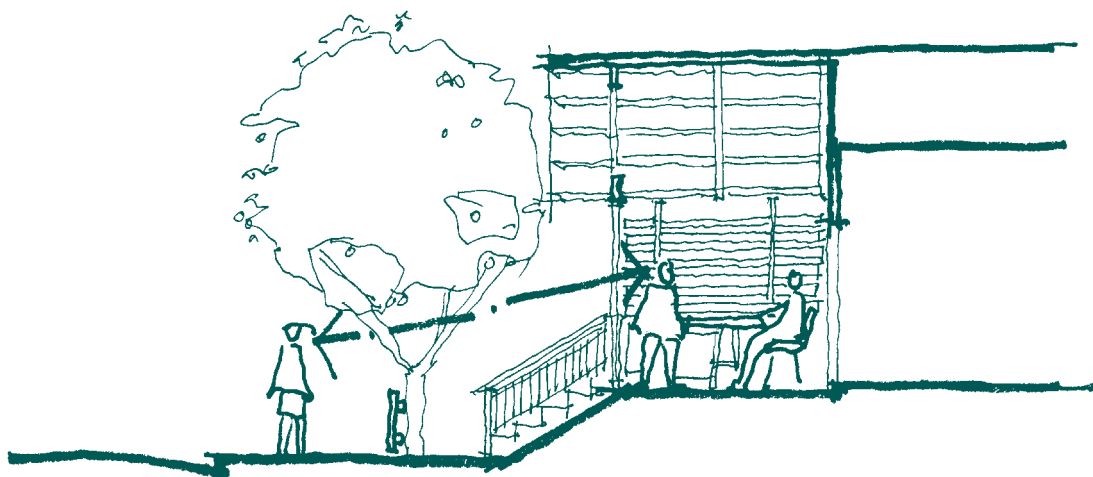

Figure 15: "Natural" surveillance to the street

ELEMENT B2

Building Appearance and Neighbourhood Character

INTENT

To ensure that a building's appearance from public streets and adjoining sites is attractive and visually compatible with either attractive surrounding development or the future urban character of the area, as identified in a Local Government's planning scheme.

PERFORMANCE CRITERIA

The intent may be achieved where:

- P1** The frontage of the building and its entry is readily apparent from the street.
- P2** Building height at the street frontage maintains a compatible scale with adjacent development.
- P3** Buildings are designed to reflect relevant features of the prevailing character of surrounding streetscapes, features and built form character that have been identified as part of the desired future character of the area.
- P4** Buildings are designed to enhance the identified desirable existing built form character by translating the following characteristics found in the surrounding built form into innovative design solutions:
- mass and proportion;
 - building materials, patterns, textures, colours, and decorative elements;
 - ground-floor height above natural ground level;
 - floor to ceiling height;
 - roof form and pitch;
 - facade articulation, detailing, and window and door proportions;
 - verandahs, eaves and parapets;
 - driveway crossovers, fence style and alignment.
- P5** The appearance of dwelling units within a multi-unit development is varied if they are located in an established area of diverse building styles.

ACCEPTABLE SOLUTIONS

The Acceptable Solutions illustrate ONE WAY of meeting the associated Performance Criteria:

- A1.1** A Streetscape Concept Plan and/or Landscape Plan is submitted that demonstrates how the Performance Criteria are met.

OR

- A1.2** A building adjacent to the public street addresses the street by having a front door or living room or kitchen windows facing the street.

- A2** Differences in building height between existing buildings and a new dwelling are not more than one storey when viewed from the public street and adjoining properties. This requirement applies to the building for a depth of one room.

(in partial satisfaction of P3 and P4)

- A3.1** A Development Plan, Streetscape Concept Plan and/or Landscape Concept Plan is submitted demonstrates how the Performance Criteria are met.

AND

- A3.2** The building's design, roof form, detailing and materials visible from public areas and adjoining properties are not in strong visual contrast with the character of attractive neighbouring buildings.



Figure 16: Building appearance and neighbourhood character

ELEMENT B2

Building Appearance and Neighbourhood Character continued

PERFORMANCE CRITERIA

- P6** New development complements or enhances any treed landscape character of the area by:
- providing sufficient open space for the planting of trees to complement the landscape character of the neighbourhood;
 - retaining and protecting existing vegetation where possible;
 - protecting neighbouring trees from damage to their root systems;
 - using building footing designs, where necessary, that allow root growth of large trees.
- P7** The building design, detailing and finish provide an appropriate scale to the street, add visual interest and enable differentiation between dwellings when viewed from public streets.
- P8** Buildings are designed and sited to acknowledge the private open space of surrounding development, by:
- keeping upper storey parts of buildings away from neighbouring private open space so as to avoid an unreasonable sense of visual enclosure; and
 - using articulation, colour and detailing to reduce visual bulk.
- P9** Garages and parking structures are sited and designed so as not to dominate the street frontage, by:
- minimising the frontage width;
 - minimising obtrusive projections of the structures beyond the main face of the building; and
 - ensuring that roof form, materials and detailing complement that of the associated dwelling.
- P10** Existing dwellings in sound condition that contribute to the streetscape character and items of heritage or conservation significance are retained, incorporated and sympathetically treated, where possible.

ACCEPTABLE SOLUTIONS

(in partial satisfaction P8)

- A8** Carports and garages are designed to be compatible with the building design and with a maximum internal width of garage or carport of 6m or 50% of the frontage width, whichever is the less, where they face the street.

- A10** Items of heritage or conservation significance retained and sympathetically treated.

ELEMENT B3

Fences and Walls

INTENT

To ensure that front fences and walls, where used, improve amenity for residents and contribute positively to the streetscape and adjacent buildings.

PERFORMANCE CRITERIA

The intent may be achieved where:

- P1** Subject to P2, front fences and walls enable some outlook from buildings to the street to achieve safety and surveillance.
- P2** Where appropriate, front fences and walls enable use of private open space abutting the street and/or provide an acoustic barrier if traffic noise is excessive.
- P3** Front fences and walls assist in highlighting entrances.
- P4** The design and materials of front fences and walls are compatible with the associated development and with attractive fences and walls in the nearby visible locality.
- P5** Front fences and walls are compatible with facilities in the street frontage area, such as mail boxes and garbage collection areas.
- P6** The use and/or design of fences and walls in streetscapes of significance is appropriate to the heritage context.
- P7** Where overland water flows are probable, fences with strip footings provide for the movement of surface stormwater.

ACCEPTABLE SOLUTIONS

The Acceptable Solutions illustrate ONE WAY of meeting the associated Performance Criteria.

(in relation to P1 and P2)

- A1** A Streetscape Concept Plan and/or Landscape Plan is submitted that demonstrates how the Performance Criteria are met.
- OR
- A2** Front fences and walls are no more than 1.2m high if solid (forward of the building line). This height may be increased to 1.8m if the fence has openings which make it not less than 50% transparent.
- OR
- A3** Solid front fences and walls to 1.8m high are limited to where:
- the main private open space is in front of the dwelling;
- OR
- traffic volumes exceeds 6000vpd;
- OR
- climatic considerations would provide a benefit to the dwelling or outdoor space.
- PROVIDED THAT:
- the width is limited to a maximum of 75% of the frontage where private open space fronts the street;
 - some surveillance of the street is maintained from the dwelling;
 - fences do not exceed 10m in length without some articulation or detailing to provide visual interest.

ELEMENT B3

Fences and Walls *continued*

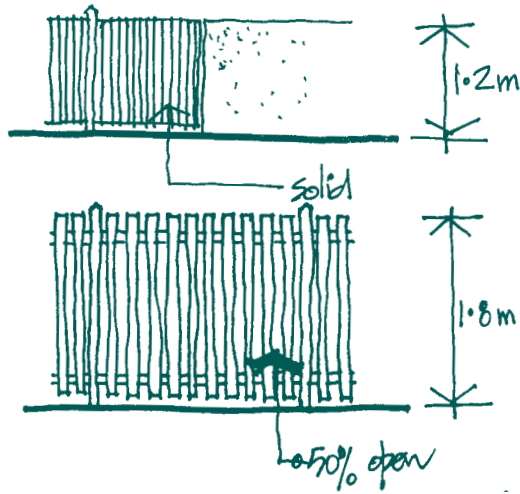

Figure 17: Typical front fences / walls

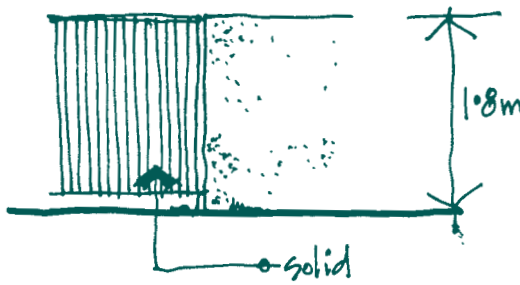

Figure 18: Fences for special privacy or noise control



Figure 19: Fence / wall articulation

ELEMENT B4

Bushfire Protection

INTENT

To reduce the level of fire risk associated with building in bushfire-prone areas by adopting suitable passive and active protection measures relating to siting, layout, design and construction techniques, and landscaping.

PERFORMANCE CRITERIA

The intent may be achieved where:

- P1** Building design and materials are selected to maximise resistance to fire.
- P2** In moderate and high-risk bushfire areas, an external sprinkler system is fitted to protect the walls and roof of a dwelling.
- P3** Each attached housing site is provided with a safe and secure water supply for fire fighting and protection.
- P4** Landscaping is designed to provide protection to buildings and not increase the level of bushfire risk.
- P5** The site layout of the building, paths and landscaping creates a building protection zone and allows for ease of access to and from dwellings and other buildings.
- P6** Design of the roof drainage system is appropriate to the bushfire hazard of the area.
- P7** The internal road layout, design and construction take account of the needs of emergency vehicles and possible evacuation.

ACCEPTABLE SOLUTIONS

The Acceptable Solutions illustrate ONE WAY of meeting the associated Performance Criteria.

- A1** Buildings comply with the Building Code of Australia requirements for construction in bushfire-prone areas, and with relevant State or local authority regulations.

ELEMENT B5

Housing on Traffic Routes

INTENT

To ensure that attached housing located next to major roads is designed and constructed in a manner that reduces the adverse impact of traffic and leads to attractive streetscapes, functional roads and comfortable living conditions.

PERFORMANCE CRITERIA

The intent may be achieved where:

- P1** Buildings are sited in a manner which:
- minimises the infiltration of noise into the buildings and the lot;
 - provides an acoustic barrier for private and communal open space;
 - reduces reflection of noise onto other buildings;
 - precludes the need to reverse on to a major road (for new lots and where the nature of an existing lot makes this possible).
- P2** Front fences and walls are designed to:
- supplement the noise control of the building facade;
 - enable some outlook to the street;
 - highlight entrances;
 - provide continuity and visual interest to the streetscape.
- P3** Higher side boundary fences and walls are designed or treated to reduce the angle of view to the noise source and minimise reflection on to the facade.
- P4** The room layout within dwellings is arranged to reduce the impact of noise on the rooms which are most sensitive to noise (eg bathrooms, hallways/stairways, storage rooms, and garages).
- P5** Balconies and other external building elements are located, designed and treated to minimise infiltration and reflection of noise onto the facade.
- P6** The building plan, walls, windows, doors and roof are designed and detailed to reduce intrusive noise levels.

ACCEPTABLE SOLUTIONS

The Acceptable Solutions illustrate ONE WAY of meeting the associated Performance Criteria.

(in partial satisfaction of P1 to P8)

- A1** Buildings are constructed in accordance with Australian Standard 3671: Acoustics – Road Traffic Noise Intrusion, Building Siting and Construction, and Australian Standard 2107: Acoustics – Recommended Design Sound Levels and Reverberation Times for Building Interiors.

ELEMENT B5

Housing on Traffic Routes continued

PERFORMANCE CRITERIA

- P7** The integrity of the wall as a barrier to noise is maintained while providing adequate cross-flow ventilation and allowing natural light to penetrate the building.
- P8** The design and appearance of the facade of the building facing the traffic route achieve human scale and proportion, and reflect and reinforce the desired residential character of the area.
- P9** Landscaping is designed which:
- provides a sense of separation between the road and the private living environment;
 - is durable and suited to the conditions of the road environment.

ACCEPTABLE SOLUTIONS

ELEMENT B5

Housing on Traffic Routes *continued*

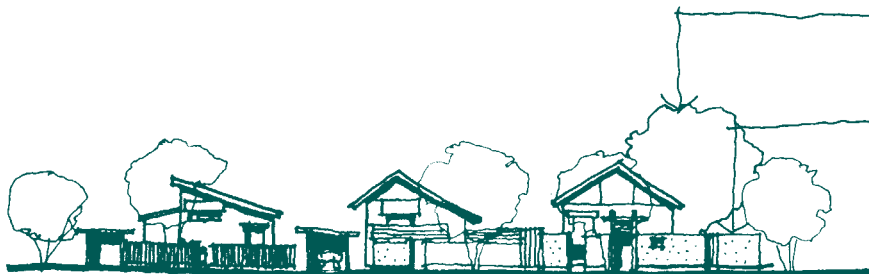
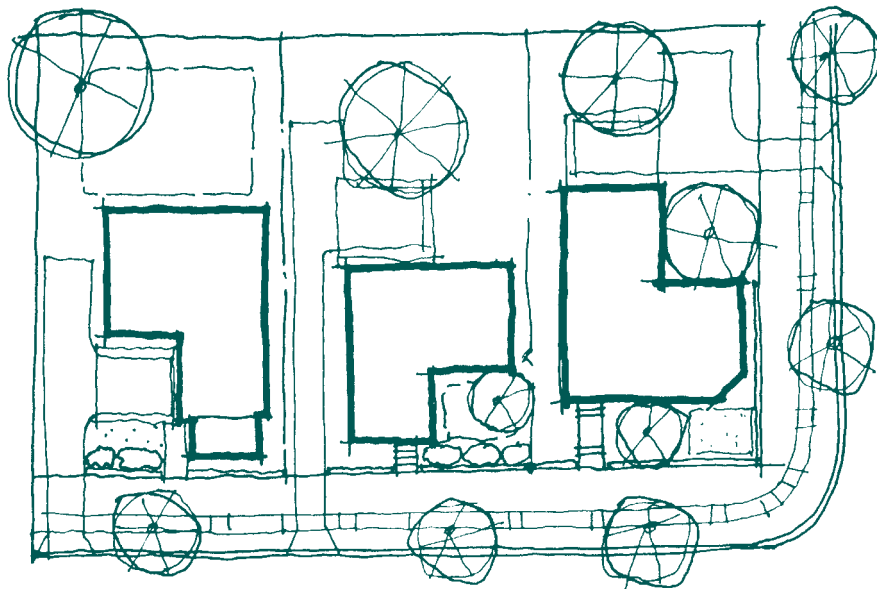

TREES AND PLANTINGS ON THE STREET MAKE A VISUAL BARRIER AND CAN SOFTEN A HARSH STREET ENVIRONMENT.

HOUSING, WALL AND FENCING DESIGNED FOR NOISE CONTROL CAN BE ARTICULATED AND VARIED.

NOISE CONTROL SHOULD NOT DETRACT FROM THE STREET CHARACTER AND SENSE OF IDENTITY
(NOTE: THIS ELEVATION SHOWS HOUSE FORMS BEHIND FENCES, WALLS AND LANDSCAPE)



TREES AND PLANTING ON THE STREET CREATE A VISUAL BARRIER AND SOFTEN THE STREET ENVIRONMENT

NOISE BARRIER WALLS AND FENCES CAN BE ARTICULATED AND VARIED TO ADD TO THE STREET SCAPE

ARTICULATION AND IDENTITY AT THE STREET FACADE
(NOTE: THIS ELEVATION SHOWS FENCES, WALLS AND LANDSCAPE ONLY)

Figure 20: Housing on traffic routes

DEFINITIONS

Acceptable Solution means an example of what may satisfy the relevant Performance Criteria (they should not preclude other solutions).

Access place means a minor cul-de-sac street providing local residential access, with shared traffic, pedestrian and recreation use.

Access street means a street providing local residential access with shared traffic, pedestrian and recreation use with local traffic access priority.

AMCORD means the Australian Model Code for Residential Development – A national resource document for residential development – November 1995.

AS means Australian Standard.

Balcony means any balustraded platform, 0.3 metres or more above adjacent finished ground level, either cantilevered or supported over open space, with access from the building via a door or window and with a minimum width of 1 metre.

BCA means Building Code of Australia.

Building envelope means a diagram drawn on a lot of a subdivision plan to the requirements of the Responsible Authority defining the limits for the siting and/or wall height of any dwellings and/or outbuildings, private open space, driveways and/or garages/carports.

Building height means the distance between natural surface level of the ground and the apex of a building's roof, but not including any receiving antennae, chimneys or flues.

Carriageway means the area of street or road reserve which is provided for the movement or parking of vehicles.

Casual surveillance refers to the ability to informally observe an area to enhance the level of security.

Collector Street – A street providing for local residential access and local traffic movement within performance limits defined in Queensland Streets.

Communal open space means usable community open space for recreation and relaxation of residents of a housing development and which is under the control of a body corporate or equivalent.

Communal street means the carriageway providing access to a housing development and which is under the control of a body corporate or equivalent.

Community Title refers to title given under the provisions of the Body Corporate and Community Management Act 1997 (BCCM Act) (formerly known as 'group title' under the Building Units and Group Titles Act 1980, which has been replaced by the BCCM Act).

Crossover refers to the paved accessway between the carriageway of a street and a development site.

Detached dwelling means a separate house on an individual lot (including a community title lot).

Development Area means an area identified as having potential for housing following strategic planning and study.

Duplex means a building comprising two attached dwellings on the same lot.

Established area means an existing neighbourhood where the vast majority of land is developed.

Flat or apartment (including attached to a shop, office etc) includes one or more of the following:

- units constructed over the top of each other;
- shared communal open space in lieu of or as well as private open space;
- shared parking/access arrangements;
- attached to a detached dwelling (with shared access/site facilities).

Frontage means the street alignment at the front of a lot and in the case of a lot that abuts two or more streets, the boundary of which, when chosen, would enable the lot to comply with these provisions.

Habitable room means a room used for normal domestic activities that includes:

- a bedroom, living room, lounge room, music room, television room, kitchen, dining room, sewing room, study, playroom and sunroom,

but excludes:

- a bathroom, laundry, water closet, food storage pantry, walk-in wardrobe, corridor, hallway, lobby, photographic darkroom, clothes drying room, and other spaces of a specialised nature occupied neither frequently nor for extended periods.

Height of a wall at any point for the purpose of determining its setback from a boundary means the vertical distance between the top of the eaves at the wall line, parapet or flat roof (not including a chimney), whichever is the highest, and the natural ground level of the lot boundary at a point at right-angles to the wall. Where a skillion roof occurs, the height shall be measured as the median height of the wall. When a triangular gable roof occurs, the heights shall be measured as the height of the wall together with one-third of the vertical height of the gable.

DEFINITIONS *continued*

Infill housing is a general term used for new housing in existing residential areas and usually involving the use of a vacant site or the removal of an existing dwelling to enable construction of a larger number of dwellings.

Intent (or Element Intent) means a statement of the desired outcomes to be achieved in the completed development, relating to particular Design Elements.

Landscape plan means a plan or document outlining the extent, type and location of proposed landscaping and planting.

Lot means an area of topographical space shown on an approved plan of subdivision and on which it is intended to construct a dwelling or dwellings.

Multi-unit dwellings means the development of more than one dwelling on a site where facilities are shared (eg access, parking, communal open space/facilities).

Nature strip refer to verge.

Outermost projection means the outermost projection of any structural part of a building or other structure including, in the case of a roof, the outside face of the fascia, or the roof structure where there is no fascia, but does not include any rainwater fittings, ornamental or architectural attachment.

Performance Criteria means criteria to be used in the preparation, submission and assessment of development proposals for measuring performance of the proposals against the Element Intent.

Plan of Development means a plan approved as part of a planning process which identifies the precise conditions for housing and other activities.

Private open space means an open area of land or building attached to a dwelling (eg balcony or roof garden) intended for the exclusive use of the occupants of the dwelling, and located and designed so as to offer visual privacy to the occupants.

Public open space means land used or intended for use for recreational purposes by the public and includes parks, public gardens, riverside reserves, pedestrian and cyclist accessways, playgrounds and sports grounds.

Setback means the shortest distance measured horizontally from the outermost projection of the building or other structure concerned to the vertical projection of the boundary of the allotment.

Site analysis involves the identification and analysis of the existing urban character and adjacent properties to assist in understanding the locality and the development of a range of appropriate design responses.

Site Analysis Plan means a plan which demonstrates an appreciation of a site and its context to identify opportunities and constraints on site layout and design. The plan may include information on topography and services, existing buildings on site, vegetation on site, adjoining property conditions, views, noise sources and street character and context.

Site density means the ratio of dwellings to the area of the site they occupy (including communal streets and communal open space).

Site means the lot(s) of land on which a building stands or is to be erected.

Storey means a space within a building which is situated between one floor level and the floor level next above, or if there is no floor above, the ceiling or roof above. It does not include a room contained wholly within the roof space or a parking area contained wholly within a basement which is below the natural ground level.

Street – Any street, lane, square, court, alley and other carriageways whose primary purpose is providing access to residential buildings.

Street pavement see Carriageway.

Street reserve means the land set aside for a street pavement and verge.

Streetscape plan means the portion of the development plan showing the visible components within a street (or part of a street) between facing buildings, including the form of buildings, setbacks, fencing, landscaping, driveway and street surfaces, utility services and street furniture such as lighting, signs, barriers and bus shelters.

Subdivision means the division of a parcel of land into two or more parts for the purpose of enabling any of the lots to be disposed of separately.

Verge means that part of the street or road reserve between the carriageway and the boundary of adjacent lots (or other limit to street reserve). It may accommodate public utilities, footpaths, stormwater flows, street lighting poles and planting.

Wall height refer to Height of Wall.

Weighting means a process of determining priorities for various Design Elements and Performance Criteria in the consideration of designing and assessing development proposals.

Window includes a roof skylight, glass panel, glass brick, glass louvre, glazed sash, glazed door, translucent sheeting or other device which transmits natural light directly from outside a building to the room concerned.

REFERENCES

Australian Road Research Board (ARRB) (1989): Structural design guide for residential street pavements, Special Report No. 41 prepared by P.J. Mulholland.

Department of Primary Industries-Water Resources (DPI), Institute of Municipal Engineering Australia, Qld. Division, Brisbane City Council (November 1994): Queensland urban drainage manual, (OUDM) prepared by Neville Jones and Associates Pty Ltd and Australian Water Engineering.

Institute of Municipal Engineering Australia, Qld Division (IMEAQ) (1993, incorporating 1996 update): Queensland streets-design guidelines for subdivisional streetworks, prepared by Weathered Howe Pty Ltd.

Whelans and Halpern Glick Maunsell (1994): Planning and management guidelines for water-sensitive urban (residential) design, Report prepared for Dept Planning and Urban Development, Water Authority of WA and EPA, Perth.

APPENDIX

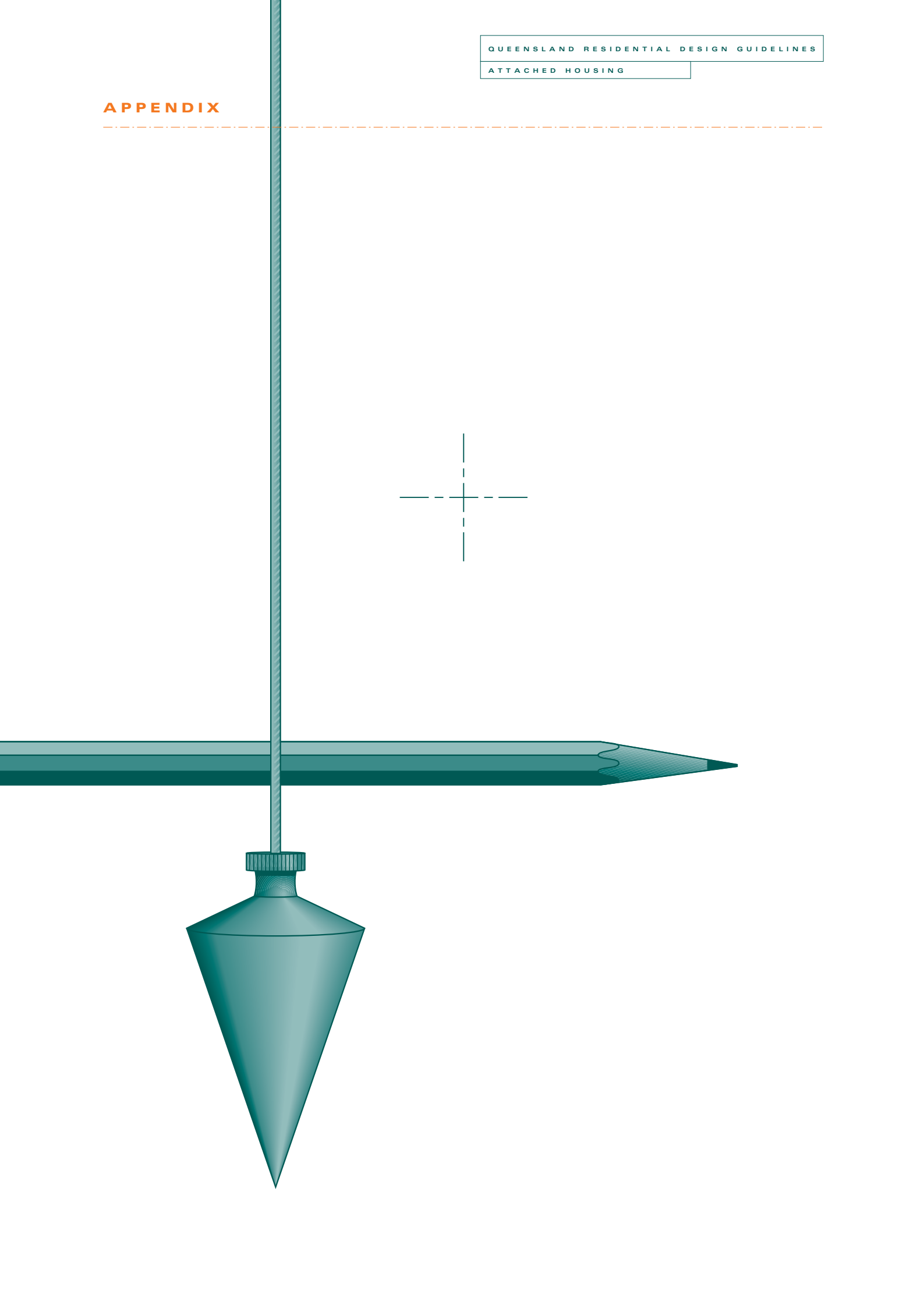

ELEMENT C1

Safety and Security

INTENT

To provide personal and property security for residents and visitors and enhance perceptions of community safety.

PERFORMANCE CRITERIA

The intent may be achieved where:

- P1** The dwelling unit and/or the private open space area is designed to overlook public and communal streets and other public areas to provide casual surveillance.
- P2** Site planning, buildings, fences, landscaping and other features clearly define territory and ownership of all public, common, semi-private and private space.
- P3** Appropriate lighting is provided to all pedestrian paths between public and shared areas, parking areas and building entries, and building entries provide a sense of security for both residents and visitors.
- P4** Large development sites are 'subdivided' into specific territorial zones which are 'assigned' to groups of dwellings.
- P5** Buildings are designed to minimise access between roofs, balconies and windows of adjoining dwellings.
- P6** Vulnerable materials are avoided and robust materials which are aesthetically pleasing are used in public or communal spaces.
- P7** Pedestrian site access and carparking are clearly defined, appropriately lit, visible to others and provide direct access to buildings from areas likely to be used at night.

SUGGESTED SOLUTIONS

The Suggested Solutions illustrate ONE WAY of meeting the associated Performance Criteria.

- A1** A dwelling unit adjacent to public or communal streets or open space has at least one habitable room window with an outlook to that area.

OR
- A1.1** The primary area of private open space overlooks the street and/or other public areas.

(in partial satisfaction of P3 and P4)
- A3.1** The dwelling unit design allows visitors who approach the front door to be seen without the need to open the door.

AND
- A3.2** Shared entries serve a maximum of eight dwelling units and are able to be locked.

ELEMENT C1

Safety and Security continued

PERFORMANCE CRITERIA

- P8** Major pedestrian, cycle and vehicle thoroughfares are identified and reinforced as 'safe routes' through:
- appropriate lighting;
 - the potential for casual surveillance from houses;
 - minimised opportunities for concealment;
 - landscaping which allows long-distance sight lines;
 - avoidance of 'blind' corners.
- P9** Individual dwelling units are clearly identifiable by visitors and emergency vehicles.
- P10** Public facilities, including public toilets and street furniture, are located to maximise opportunities for casual surveillance, and are designed and constructed of high-quality, robust materials.
- P11** A diversity of complementary land-use activities is provided to encourage a public presence at different times of the day and night.
- P12** Landscape and fencing do not present a security risk by screening doors, windows and major paths.

SUGGESTED SOLUTIONS

ELEMENT C2

Design for Climate

INTENT

To facilitate energy and water conservation measures in and around housing that will assist in establishing ecologically sustainable residential environments, through the reduction in household use of fossil fuels and greenhouse gas emissions and the use of renewable energy sources.

PERFORMANCE CRITERIA

The intent may be achieved where solar access is available and where:

In all climates

- P1** Building envelopes and internal layouts are designed to minimise energy consumed for heating and cooling.
- P2** Windows are located, sized and shaded to facilitate good thermal performance.
- P3** Buildings have an area of roof, with appropriate orientation and pitch, that is suitable for the installation of solar collectors and photovoltaic cells.
- P4** Building materials and insulation assist in providing acceptable thermal conditions.
- P5** Air movement within dwellings is designed to provide acceptable thermal conditions.
- P6** Building materials, appliances and fuel sources are selected to minimise energy requirements and greenhouse gas emissions.
- P7** Landscape design assists microclimate management to conserve energy and water.
- P8** Building and landscape design incorporate techniques for conserving mains water.

SUGGESTED SOLUTIONS

The Suggested Solutions illustrate ONE WAY of achieving the Performance Criteria:

In all climates

(in relation to P1 to P5)

- A1** There is a minimum rating of four stars for any dwelling on its own separate lot, or four stars for 50% of dwelling units and three stars for the remaining dwellings within a multi-unit housing development, under a nationally accredited House Energy Rating Scheme.

OR

(in partial satisfaction of P1 to P5)

- A2.1** Doors, windows and other openings have adequate draught control.
- AND
- A2.2** Mechanically heated or cooled areas can be closed off from other areas of the dwelling.
- AND
- A2.3** Buildings (other than in the hot-humid climate zone) are sited within the preferred orientation range shown in Figure 21.
- AND
- A2.4** A north-facing room is provided, capable of use as a living area.
- AND
- A2.5** Ceiling and wall insulation is provided to at least the level recommended in AS 2627.1-1993 for the locality.

AND

ELEMENT C2

Design for Climate continued

PERFORMANCE CRITERIA

In temperate climates

- P9** Buildings are sited and designed to maximise solar access to north-facing windows of living areas and principal areas of open space, having regard to slope, views, existing vegetation and overshadowing.
- P10** Windows are appropriately sized and shaded to reduce summer heat load and permit entry of winter sun.

In cool-temperate climates

- P11** Buildings are sited and designed to maximise solar access to north-facing windows of living areas and principal areas of open space, having regard to slope, views, existing vegetation and overshadowing.
- P12** Buildings are designed for maximum solar access during cooler months.
- P13** Buildings and landscaping are designed to ensure protection from winter winds.
- P14** Buildings are mainly constructed of materials with high thermal mass.

SUGGESTED SOLUTIONS

In all climates (continued)

- A2.6** External clothes drying areas with access to sunlight and breezes are available.

In temperate climates

(in partial satisfaction of P9 and P10)

- A9.1** Windows to north-facing living areas receive at least 3 hours of sun between 9am and 5pm on 21 June over a portion of their surface.
- AND
- A9.2** North-facing windows to living areas of neighbouring dwellings do not have sunlight reduced to less than the above 3 hours.
- AND
- A9.3** Materials of high thermal mass are used for living areas and are located to maximise the absorption of heat from air circulating in the dwelling and from the winter sun.

In cool-temperate climates

(in partial satisfaction of P11 to P14)

- A11.1** Windows to north-facing living areas receive at least 3 hours of sun between 9am and 5pm on 21 June over a portion of their surface.
- AND
- A11.2** North-facing windows to living areas of neighbouring dwellings do not have sunlight reduced to less than the above 3 hours.
- AND
- A11.3** East-facing windows (with external shading to restrict summer sun) are provided for morning sunlight during cooler months.

ELEMENT C2

Design for Climate continued

PERFORMANCE CRITERIA

In hot-humid climates

- P15** Buildings are sited to maximise the use of cooling breezes and provide natural ventilation.
- P16** Buildings are designed to:
 - minimise the need for mechanical cooling;
 - maximise cross-ventilation;
 - use shade structures over all windows and external doors;
 - naturally ventilate roof spaces;
 - provide for covered outdoor living areas;
 - avoid long walls along western boundaries.
- P17** Fences are of semi-open construction for breeze penetration.
- P18** Trees and vegetation provide as much shade as possible both on-site and on-street.

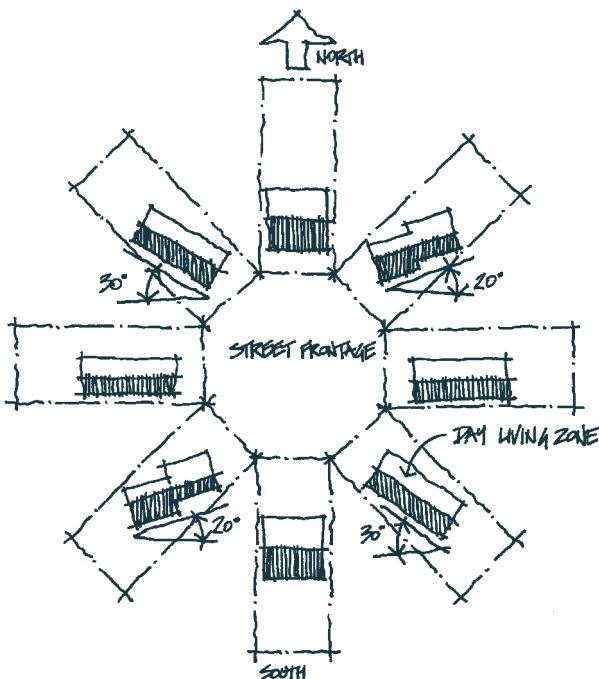

Figure 21: Suggested positioning of houses on sites with varied aspects to achieve low-energy housing in temperate climate zones

SUGGESTED SOLUTIONS

In hot-humid climates

(in partial satisfaction of P15 to P18)

- A15.1** Buildings are designed with openings on opposite or adjacent walls for cross-ventilation.
AND
- A15.2** All habitable rooms are naturally ventilated, with a minimum openable area of 5% of the floor area of that room.
AND
- A15.3** All external openings are protected from direct sunlight by permanently fixed shade devices.
AND
- A15.4** Roof spaces are ventilated with louvre openings (eg gable end) or by roof-mounted ventilators (subject to Cyclone Code).
AND
- A15.5** Verandahs and balconies are provided and are not less than 10m² with a minimum dimension of 2.5m, and are covered for a minimum of 30% of their area.
AND
- A15.6** Roofs are lightweight and light-coloured, and roofs and walls are insulated to at least the level recommended in AS 2627.1-1993.
AND
- A15.7** A vapour barrier membrane is installed on the outside of the bulk insulation. Perforated breather paper is installed in all other walls (to restrict condensation buildup).
AND
- A15.8** Lightweight materials are used in buildings in the most northern and hotter regions, particularly within bedrooms.

ELEMENT C2

Design for Climate continued

PERFORMANCE CRITERIA

In hot-arid climates

- P19** Buildings incorporate courtyards with summer shade and vegetation.
- P20** Buildings are designed to provide midday shade all year round but with some early morning solar penetration.
- P21** Buildings are sited to maximise the use of cooling breezes.
- P22** Buildings are designed to:
- minimise the need for mechanical cooling;
 - maximise cross-ventilation;
 - use shade structures over all windows and external doors;
 - naturally ventilate roof spaces;
 - provide for covered outdoor living areas;
 - avoid long walls along western boundaries.
- P23** Trees and vegetation provide as much shade as possible both on-site and on-street.

SUGGESTED SOLUTIONS

In hot-arid climates

(in partial satisfaction of P19 to P23)

- A19.1** Buildings and landscaping are sited and designed to provide shade to walls and the roof all year round.
- AND
- A19.2** Courtyards are provided with summer shade and vegetation.
- AND
- A19.3** Walls to living areas are constructed using materials of high thermal mass and walls to bedrooms are constructed using materials of low thermal mass.
- AND
- A19.4** Buildings are sited to maximise available cool breezes.
- AND
- A19.5** Buildings are designed with openings on opposite or adjacent walls for cross-ventilation.
- AND
- A19.6** All habitable rooms are naturally ventilated, with a minimum openable area of 5% of the floor area of that room.
- AND
- A19.7** All external openings are protected from direct sunlight by shade devices.
- AND
- A19.8** Roof spaces are ventilated with louvre openings (eg gable end) or by roof-mounted ventilators and are bulk insulated.

ELEMENT C2

Design for Climate *continued*

PERFORMANCE CRITERIA

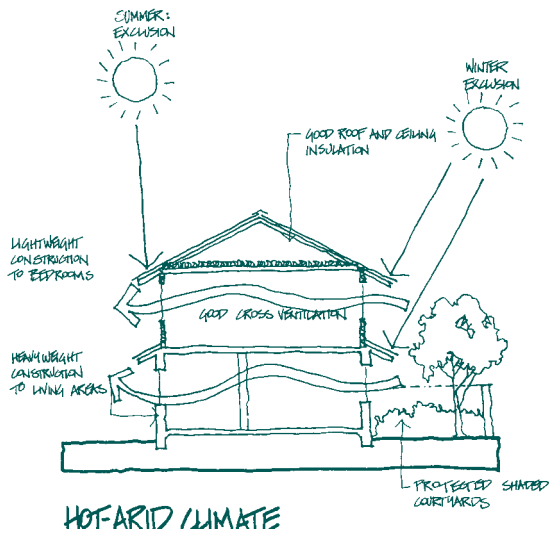

SUGGESTED SOLUTIONS

In hot-arid climates (continued)

AND

A19.9 Verandahs and balconies are provided and are not less than 10m² with a minimum dimension of 2.5m, and are covered for a minimum of 30% of their area.

AND

A19.10 Roofs are lightweight and light-coloured, and roofs and walls are insulated to at least the level recommended in AS 2627.1-1993.

AND

A19.11 A vapour barrier membrane is installed on the inside of the bulk insulation in order to restrict condensation buildup.

AND

A19.12 The house is designed with a longer east-west axis.

AND

A19.13 Windows are located on the north and south walls only.

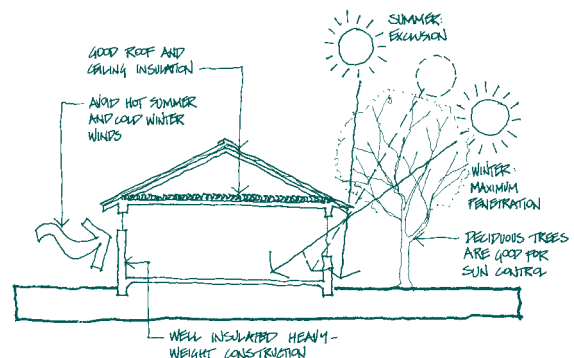
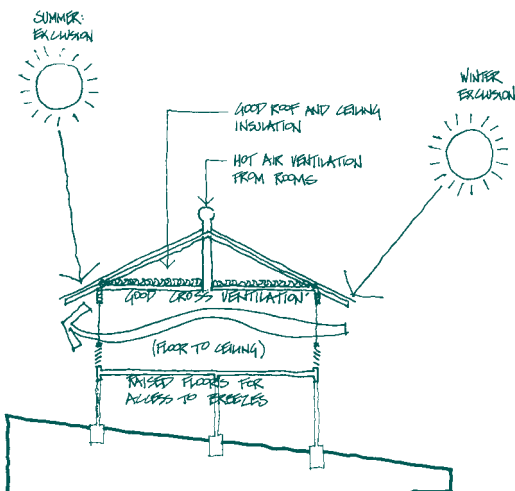

ELEMENT C3

Privacy

INTENT

To site and design dwelling units to meet projected user requirements for visual and acoustic privacy, and to protect the visual and acoustic privacy of nearby residents in their dwellings and private open space.

PERFORMANCE CRITERIA

The intent may be achieved where:

- P1** The privacy of buildings and outdoor spaces is protected taking into account projected community expectations.

Visual privacy

- P2** Direct overlooking of main internal living areas and private open spaces of other dwellings is minimised by building layout, location and design of windows and balconies, screening devices and landscape, or remoteness. Effective location of windows and balconies to avoid overlooking is preferred to the use of screening devices, high sills or obscured glass. Where these are used, they should be integrated with the building design and have minimal negative effect on residents' or neighbours' amenity.

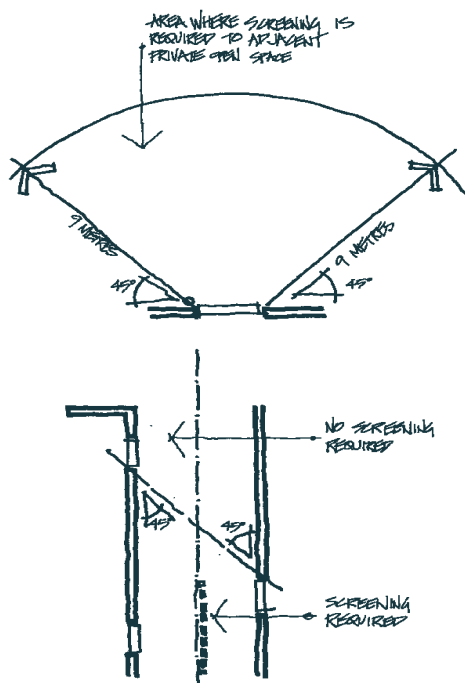

Figure 25: Privacy
Outlook from windows

SUGGESTED SOLUTIONS

The Suggested Solutions illustrate ONE WAY of meeting the associated Performance Criteria.

Visual privacy

- A2.1** Habitable room windows with a direct outlook to the habitable room windows in an adjacent dwelling unit within 9m:

- are offset from the edge of one window to the edge of the other by a distance sufficient to limit views into the adjacent windows;

OR

- have sill heights of 1.7m above floor level;

OR

- have fixed obscure glazing in any part of the window below 1.7m above floor level.

AND

- A2.2** Outlook from windows, balconies, stairs, landings, terraces and decks or other private, communal or public areas within a development is obscured or screened where a direct view is available into the private open space of an existing dwelling.

If screening is used, the view of the area overlooked must be restricted within 9m and beyond a 45° angle from the plane of the wall containing the opening, measured from a height of 1.7m above floor level (see Figure 25).

No screening is required where:

- windows are in bathrooms, toilets, laundries, storage rooms or other non-habitable rooms and they have translucent glazing or sill heights of at least 1.7m;

ELEMENT C3

Privacy continued

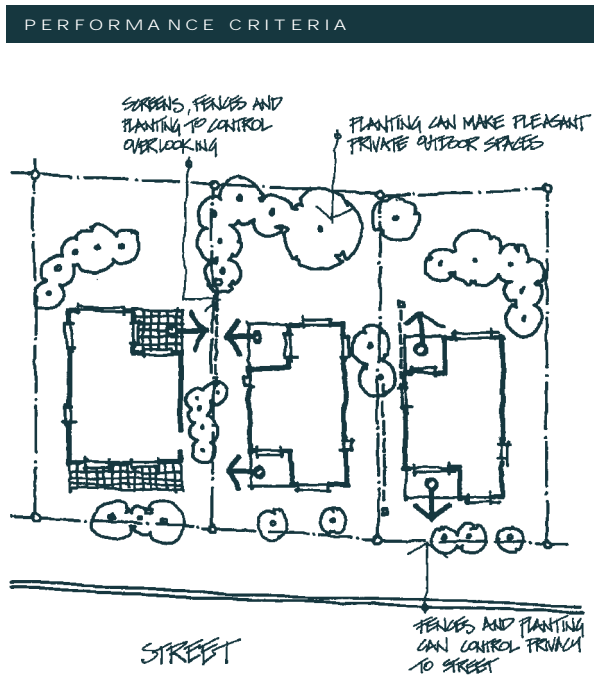

Figure 26: Privacy
Street / allotment

Acoustic privacy

- P3** Site layout separates, by way of barriers and/or by distance, active recreational areas, parking areas, vehicle accessways and service equipment areas from bedroom areas of dwelling units, and minimises high levels of external noise entering dwellings.
- P4** Dwelling units close to high-noise sources (eg busy roads, railway lines, airport flight-paths or industry) should be designed to locate noise-sensitive rooms and secluded private open spaces away from noise sources, and be protected by appropriate noise-shielding techniques.
- P5** Building design assists in minimising the transmission of sound through the building structure, and particularly protects sleeping and living areas from possible noise intrusion.

SUGGESTED SOLUTIONS

Visual privacy (continued)

- windows are in habitable rooms and they have sill heights of 1.7m or more above floor level or translucent glazing to any part of a window less than 1.7m above floor level.

AND

A2.3 Windows and balconies of an upper-level dwelling are designed to prevent overlooking of more than 50% of the private open space of a lower-level dwelling unit directly below and within the same development.

AND

A2.4 Direct views described in A2.2 and A2.3 may be obscured by solid translucent screens or perforated panels or trellises which have a maximum of 25% openings, and which are:

- permanent and fixed
- of durable materials
- designed and painted or coloured to blend in with the development.

Acoustic privacy

(in partial satisfaction of P3)

A3 Bedroom windows are at least 3m from shared streets and driveways and parking areas of other dwellings. (setback distances may be reduced where appropriate noise-shielding techniques are installed).

(in partial satisfaction of P5)

A5 Shared walls and floors between dwelling units are constructed in accordance with the noise transmission and insulation requirements of the Building Code of Australia.

ELEMENT C4

Dwelling Unit Entry and Interior

INTENT

To provide dwelling unit entries that create a sense of individual identity and offer adequate personal security for residents, and provide internal dwelling layouts to suit projected user requirements.

PERFORMANCE CRITERIA

The intent may be achieved where:

- P1** Entries to dwelling units:
- are clearly visible from streets or internal driveways so that visitors can easily identify a particular dwelling;
 - give the resident a sense of personal address, shelter and transitional space around the entry;
 - help provide a level of security for the occupants.
- P2** The dwelling unit layout ensures:
- general surveillance of the site and approaches to entries is possible from inside dwellings;
 - ground-floor dwellings are accessible to people with disabilities or can be easily modified to achieve this.
- P3** Dwelling units are planned so that:
- noise transmission between them is minimised by not locating the noisy areas of one dwelling next to the quiet areas of another;
 - circulation areas are minimised, and floor plans ensure that circulation space facilitates functional use of rooms;
 - views and outlook are maximised, particularly from living rooms;
 - internal storage space is included;
 - direct or convenient access from a living area to private open space is provided.

SUGGESTED SOLUTIONS

The Suggested Solutions illustrate ONE WAY of meeting the associated Performance Criteria.

(in partial satisfaction of P1)

- A1.1** Entries to dwelling units enable visitors to be seen from inside the dwelling without opening the door.

AND

- A1.2** Shared entries, such as semi-interior or interior stairways, corridors or balcony walkways, are limited to service a maximum of eight dwellings.

(in partial satisfaction of P3)

- A3** Garages are located away from bedrooms of adjacent dwellings.

ELEMENT C4

Dwelling Unit Entry and Interior continued

PERFORMANCE CRITERIA

- P4** Internal layout of dwelling units designed for more than one person is adaptable to a range of household types, by maximising potential for personal space and privacy through:
- providing more than one larger bedroom (suitable to fit a double bed);
 - separating bedrooms from each other with bathrooms or other rooms, or locating them next to walls with minimum noise transmission;
 - providing more than one living space or a living-dining space that can be functionally divided;
 - arranging rooms off a central circulation space connected to the entry.
- P5** Detailing of dwelling units ensures that:
- window design and location contribute to a sense of spaciousness and connection with the outdoors, while enabling control for ventilation and security;
 - room shapes and dimensions allow flexibility in use and furniture arrangement;
 - entries, doors and passageways are wide enough to allow for furniture movement and wheelchair access.

SUGGESTED SOLUTIONS

QUEENSLAND RESIDENTIAL
DESIGN GUIDELINES

Integrated

d e v e l o p m e n t

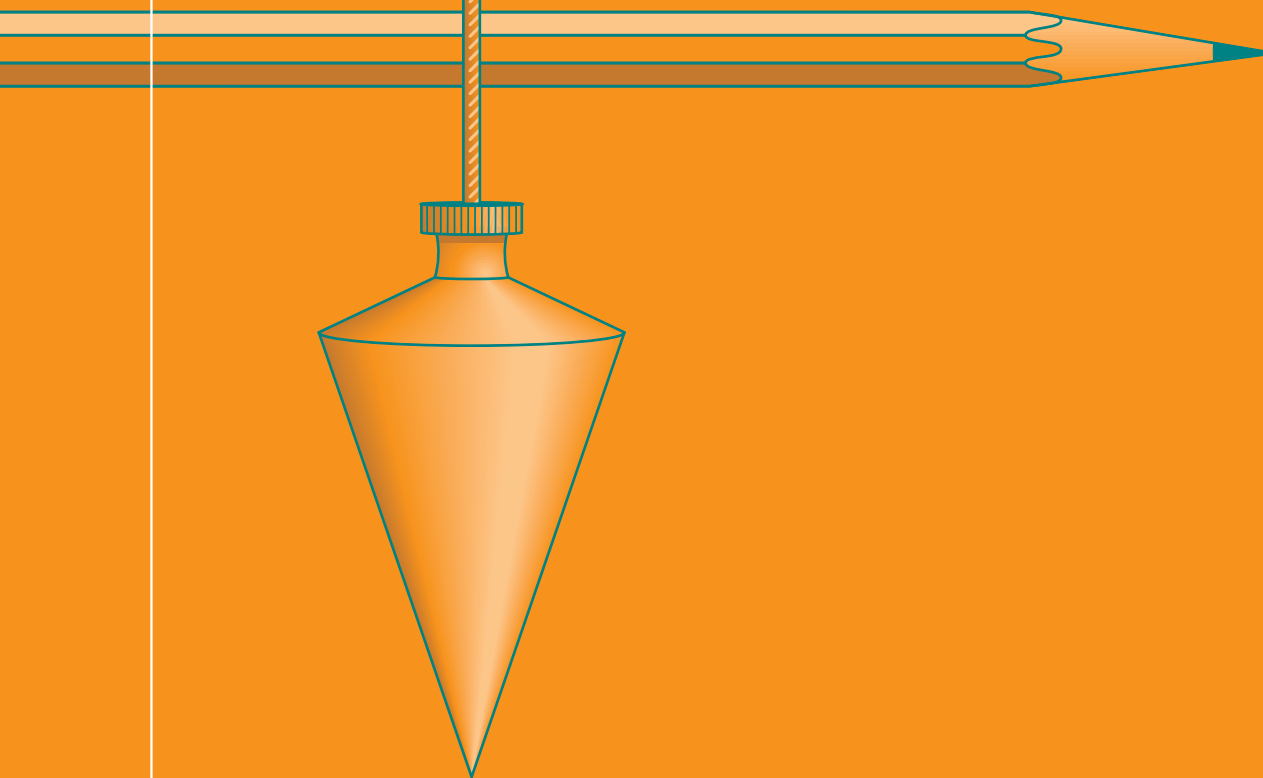

TABLE OF CONTENTS

Part 3 – Integrated Development

1.0	INTRODUCTION	1
1.1	APPLICATION OF DESIGN GUIDELINES	2
1.2	THE PERFORMANCE APPROACH	2
1.3	SITE ANALYSIS	3
1.4	DESIGN ELEMENTS	
	A GENERAL	
	A1 Neighbourhood Design	7
	A2 Street Networks	10
	A3 Public Open Space	12
	A4 Street Design	14
	A5 Street Construction	18
	A6 Utilities	19
	A7 Storm Drainage	21
	A8 Water Quality Management	24
	A9 Lot Layout	25
	A10 Street Setbacks	26
	A11 Building Envelope and Siting	28
	A12 On-site Carparking and Access	31
	A13 Private Open Space	34
	A14 Communal Open Space and Landscaping	36
	A15 Site Facilities	39
	A16 Site Works	40
	B SITE SPECIFIC	
	B1 Streetscape and Landscape	42
	B2 Building Appearance and Neighbourhood Character	45
	B3 Fences and Walls	48
	B4 Bushfire Protection	50
	B5 Housing on Traffic Routes	51
	DEFINITIONS	54
	REFERENCES	56
	APPENDIX	
	C ADVISORY DESIGN ELEMENTS	
	C1 Safety and Security	59
	C2 Design for Climate	61
	C3 Privacy	66
	C4 Dwelling Unit Entry and Interior	68
	C5 Storm Water Harvesting	70

1.0 Introduction

The Queensland Residential Design Guidelines have been produced for use by planners, designers, local government development control officers, builders, and developers involved in housing and residential development in Queensland.

The Guidelines are derived from the provisions of the Australian Model Code for Residential Development – A National Resource Document (AMCORD 1995), with modifications to suit Queensland conditions.

The Guidelines have four sections:

- 1 Single Detached Housing – for planning, design, and development of detached houses.
- 2 Attached Housing – for planning, design, and development of all forms, types, and arrangements of attached housing up to 3 storeys in height, or 3 storeys over carparking.
- 3 Integrated Development – for integrated planning, design, and development of projects comprising 2 or more houses (includes residential components of mixed-use projects).
- 4 Subdivision – for planning, design and development of land subdivision for residential purposes, prior to housing construction.

Each section :

- comprises design elements presented using a performance-based approach (including intent, performance criteria, and a range of acceptable solutions suitable for Queensland).
- includes only those design elements of relevance to the particular type of residential development under consideration.
- references to related publications such as Queensland Streets and the Queensland Urban Drainage Manual.

Queensland Streets (IMEAQ 1996) provides the basis for a uniform standard of residential streetworks design, with detailed design criteria in accordance with AMCORD principles.

The Queensland Urban Drainage Manual (DPI et al, 1993) as well as considering environmental and legal aspects, provides planning guidelines and design processes and

methods for urban stormwater drainage works in Queensland.

Each section has been prepared acknowledging that:

- certain design elements are essential to be complied with to achieve a satisfactory design solution;
- some design elements may only apply to certain parts of a local government area or may only apply to specific development applications; and
- other design elements exist which will result in a more highly sophisticated level of performance and have been included for their education role.

This has been achieved by the following organisation of the Design Elements:

General

Compliance with these elements is required to achieve an acceptable level of performance in planning, design, and development of residential projects.

Site Specific

Compliance with these elements is only required in special circumstances, where sufficient community interest warrants detailed consideration of them and/or a sophisticated residential planning, design, and development outcome is desired. These elements would usually be specified in specialised documents produced through community consultation, such as in conditions of rezoning and/or town planning consent, and/or provisions of a Development Control Plan.

Alternatively, developers might wish to voluntarily comply with these elements to dispel perceived community concerns.

Advisory

Advisory design elements have also been included as an appendix. Compliance with these design elements is not required to achieve compliance with the Residential Design Guidelines. They have been included as they are considered to be 'desirable' design elements from the perspective of creating good design outcomes. However, due to the subjective nature of the design elements and the difficulty in specifying acceptable solutions, it is not considered appropriate that these design elements be required to be complied with to achieve an approval. Consequently, the

decision to apply these design elements is to remain with the designer, rather than the approving authority.

1.1 Application of Design Guidelines

The Integrated Development Guidelines apply to all those forms of development where:

- housing and associated facilities are planned, designed and built by the same developer or through a developer – builder combination; and
- a developer undertakes the site planning and development, as well as establishing detailed requirements for building designs without actually constructing the dwellings.
- The output of the Integrated Development approval process will be a Plan of Development which will embody design control criteria to guide the design and approval of subsequent applications.

Integrated Development covers a wide range of development forms from large scale residential projects to a development of a few dwellings.

Consequently, not all design elements will apply to all applications.

The following table (overleaf) provides an indication to the elements which will usually apply to the various categories of Integrated Development.

However, each applicant should review all elements to check applicability or otherwise.

1.2 The Performance Approach

The Queensland Residential Design Guidelines adopts a performance-based system of control. Instead of specifying prescriptive standards, it focuses on matters to be addressed (called Performance Criteria) in order to achieve a desired outcome (called Intent).

Such a performance-based system centred on objectives and desired outcomes, offers an opportunity for diversity and choice, and provides flexibility to respond to market needs and preferences, and changes in approaches and technology.

Performance-based regulation is enhanced if examples of ways in which the desired result can be achieved are indicated. Acceptable Solutions are provided as examples of

what is considered acceptable, while not precluding other options.

The Acceptable Solutions illustrate ONE WAY only of meeting the associated Performance Criteria. The acceptability of other solutions would need to be demonstrated. This may be achieved with reference to built examples, plans and/or illustrations representing contemporary best practice in residential planning, design and development.

Each Design Element has a consistent format (refer figure 1). A concise statement of intent is at the top of the page (1). The left column sets the Performance Criteria (2) and the right column Acceptable Solutions (3) relates to the relevant Performance Criteria.

The Guidelines do not repeat the explanatory and background material included in AMCORD for each Design Element. This material however, should be referenced where alternative solutions are proposed, or where clarity is required in relation to the source and/or intention of the Performance Criteria.

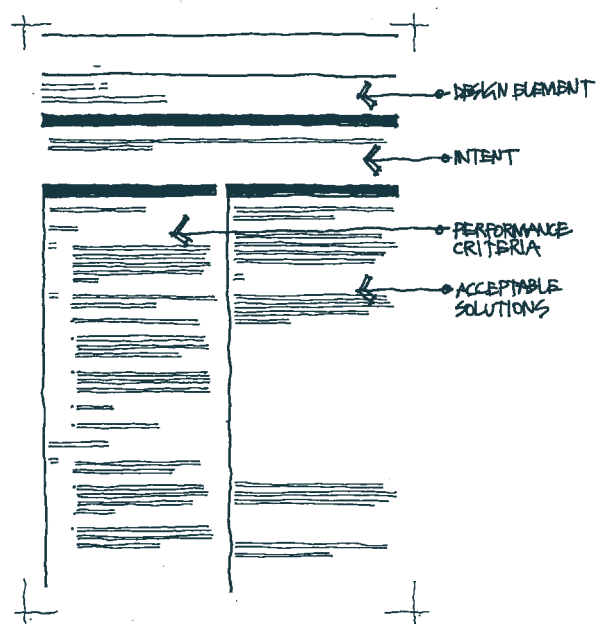

Figure 1: The layout of a typical page for a Design Element

TABLE 1.1: Applying the Subdivision Design Guidelines to Different Sizes of Subdivision

Size of Subdivision

Med = medium to large, neighbourhood size creating collector streets and above, (>100 lots)

Sml = small, part of a precinct creating access streets, (typically 10–100 lots)

Minor = minor, no public streets created (<10 lots)

Element	Med	Sml	Minor
1 Neighbourhood Design	x		
2 Street Networks	x		
3 Public Open Space	x	x	x
4 Street Design	x	x	
5 Street Construction	x	x	
6 Utilities	x	x	x
7 Storm Drainage	x	x	x
8 Water Quality Management	x	x	x
9 Lot Layout	x	x	x
10 Street Setbacks	x	x	x
11 Building Envelope and Siting	x	x	x
12 On-site Carparking and Access	x	x	x
13 Private Open Space	x	x	x
14 Communal Open Space and Landscaping	x	x	x
15 Site Facilities	x	x	x
16 Site Works	x	x	x

"x" = Indicates Element is applicable

1 Intent

The Intent outlines the aim of the Design Element and reflects identified planning and policy requirements.

In complying with the Intent, an applicant must conform to all relevant Performance Criteria. Where Acceptable Solutions have been documented to cover specific Performance Criteria, designers can use these in satisfaction of the Performance Criteria.

2 Performance Criteria

Performance Criteria are general statements of the means of achieving the Intent. They are not meant to be limiting in nature. Instead, they provide designers and developers with

an opportunity to develop a variety of design responses.

Not all Performance Criteria will be applicable to every development. In submitting a proposal for approval, the designer and developer must indicate those criteria not relevant to their particular development.

In other circumstances, some performance criteria may be found to conflict with other performance criteria. In these instances, "trade-offs" may need to be considered as part of the design and approval process in arriving at an acceptable solution.

3 Acceptable Solutions

Acceptable Solutions are provided as examples of what may satisfy the Performance Criteria. They should not be interpreted as an alternative prescriptive form of regulation, nor should they preclude other solutions.

Acceptable solutions may not be provided for all Performance Criteria. In those instances, solutions specific for each circumstance will need to be developed by the designer.

1.3 Site Analysis

A detailed and comprehensive site analysis is the foundation of any good design and should be carried out if the intent of these guidelines to be achieved.

Specifically, the objective of the site analysis is to ensure that a coherent site layout and design is achieved which:

- identifies the constraints of the site;
- highlights the site's opportunities; and
- shows the important aspects of the surrounding environment.

The site analysis plan highlights a number of aspects which can be otherwise readily overlooked, namely:

- the need for retaining walls and the impact on adjoining properties' amenity;
- redirection of overland flow paths; and
- clashes of services and building works.

The submission of a site analysis plan will assist in the development assessment process and is needed should more innovative design solutions be proposed.

COMPONENTS OF A SITE ANALYSIS

Depending on the type of development, its scale and location, the components of the Site Analysis may need to include some or all of the following:

THE SITE

- Site dimensions and site area
- Spot levels, contours and north point
- Easements for drainage and services
- Location of existing vegetation, including the height and spread of established trees
- Location of buildings and other structures
- Heritage features including any archaeological features
- Orientation, significant noise sources and micro climates (eg: keeping potential for breezes);
- Views to and from the site
- Pedestrian and vehicle access
- Identification of previous use and any contaminated soils or, where practicable, filled areas
- Location of fences, boundaries and any other notable features (natural or historical)
- Prevailing winds
- Natural drainage
- Overshadowing of the site by neighbouring structures

The site analysis should indicate the proposed arrangement of buildings and spaces on the site.

THE SURROUNDS

- The location, height and use of neighbouring buildings (including location of any facing doors and windows) and out-buildings
- The built form and character of adjacent and nearby development, including characteristic fencing and garden styles

- Abutting secluded private open spaces and living room windows which have outlooks towards the site, particularly those within 9m of the site boundaries.

The heritage significance of surrounding buildings and landscape

- Characteristics of any adjacent public open space
- Location and height of walls built to the site's boundary
- Views and solar access enjoyed by adjacent residents
- Major trees on adjacent properties, particularly those within 9m of the subject site
- Street-frontage features such as poles, street trees, kerb crossovers, bus stops and other services
- Directions and distances to local shops, schools, public transport, parks and community facilities
- The difference in levels between the subject land and adjacent properties at their boundaries
- Sources of nuisance such as flight paths, noisy roads or industries and the like.

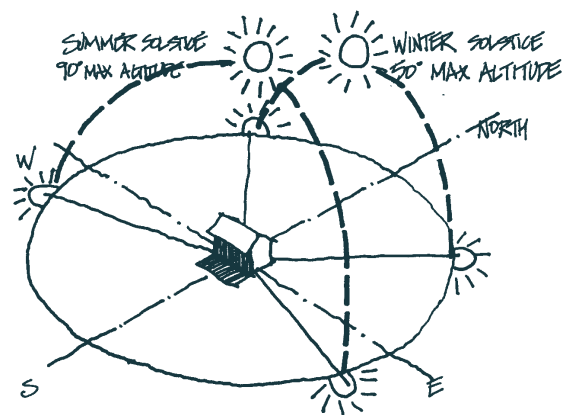

Figure 2: Solar path diagram

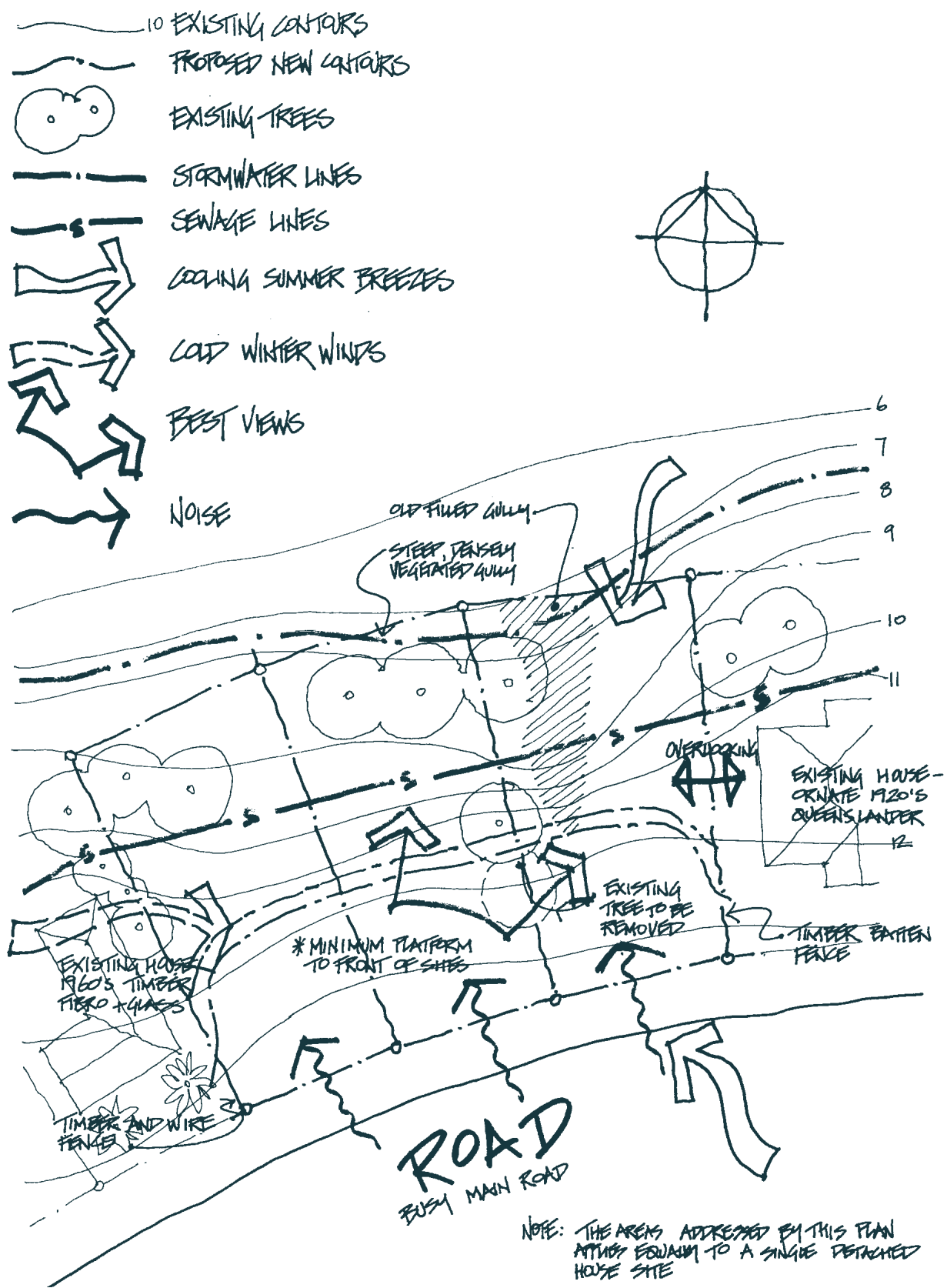

Figure 3: Typical site analysis plan

ELEMENT A1

Neighbourhood Design

INTENT

To provide safe, convenient and attractive neighbourhoods that meet the diverse and changing needs of the community. This encompasses offering a wide choice in good quality affordable housing and associated community and commercial facilities, providing for local employment opportunities, encouraging walking and cycling, minimising energy consumption, and promoting a sense of place through neighbourhood focal points and the creation of a distinctive identity which recognises and, where relevant, preserves the natural environment.

PERFORMANCE CRITERIA

The intent may be achieved where:

- P1** The subdivision layout gives a neighbourhood a strong and positive identity, by responding to site characteristics, setting, landmarks and views and through clearly readable street and open-space networks.
- P2** Neighbourhood identity is reinforced by locating community, retail and commercial facilities at focal points within convenient walking distance for residents.
- P3** The street network provides a high level of internal accessibility and good external connections for local vehicle, pedestrian and cycle movements, with traffic management to restrain vehicle speed, deter through-traffic and create safe conditions for other road users.
- P4** The vehicle, cyclist and pedestrian networks, land-use mix and lot density minimise fossil fuel use by reducing local vehicle trips, travel distances and speeds, maximising public transport effectiveness, and encouraging walking and cycling to daily activities.
- P5** The distribution and design of land uses minimise infrastructure costs.
- P6** The street and lot orientation and lot dimensions facilitate the siting and design of dwellings which conserve non-renewable energy sources and assist in design appropriate for the climatic conditions.

ACCEPTABLE SOLUTIONS

(in relation to P1 to P6)

There are no recommended Acceptable Solutions for this Element, as each situation requires an individual approach.

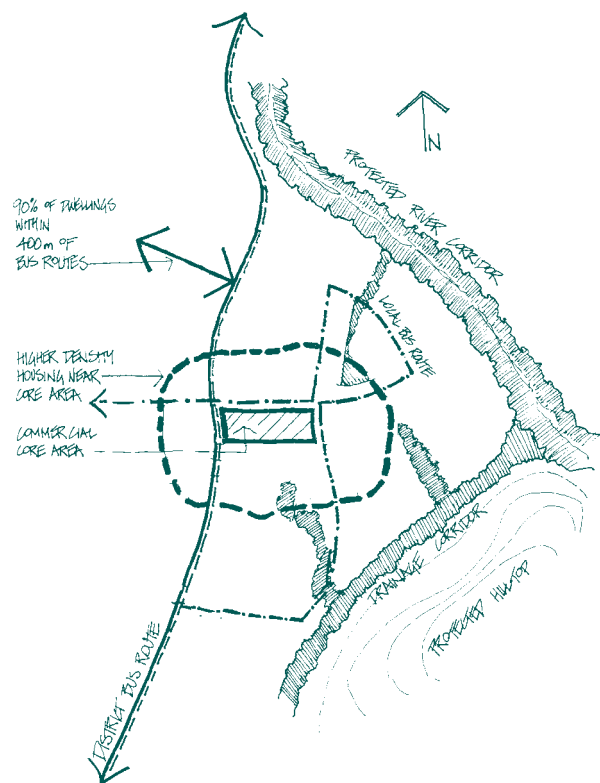

Figure 4: Neighbourhood design
Typical principles

ELEMENT A 1

Neighbourhood Design continued

PERFORMANCE CRITERIA

- P7** The street network caters for the extension of existing or future public transport routes to provide services that are convenient and accessible to the community.
- P8** The layout provides well-distributed public open spaces that contribute to the legibility and character of the development, provide for a range of uses and activities, are cost-effective to maintain, and contribute to stormwater management and environmental care.
- P9** The layout retains significant vegetation and habitat areas, incorporates natural and cultural features, minimises soil erosion and avoids development on flood-prone land.
- P10** The layout is integrated with the surrounding urban environment, complements existing attractive streetscapes and landscapes, and provides for shared use of public facilities by adjoining communities.
- P11** The layout enhances personal safety and perceptions of safety, and minimises potential for crime, vandalism and fear through achievement of surveillance by drivers of passing vehicles and pedestrians.
- P12** The pedestrian network is safe, attractive and efficient, running largely along public spaces (including streets and open spaces) fronted by houses, and avoiding uses that generate major breaks in surveillance on routes to and from public transport or those used at night.

ACCEPTABLE SOLUTIONS

- A7** At least 90% of dwellings are within 400m radial distance from an existing or potential bus route.
- A8.1** District parks, consisting of 3ha minimum area and containing a range of recreation settings, are provided within 2km of all dwellings.
- AND
- A8.2** Large local parks consisting of 0.4–1.0ha minimum area provided within 500m safe walking distance of 90% of all dwellings.
- AND
- A8.3** Small local parks consist of 0.2ha minimum area provided to serve neighbourhood needs within 300m safe walking distance of 90% of all dwellings.

ELEMENT A1

Neighbourhood Design *continued*

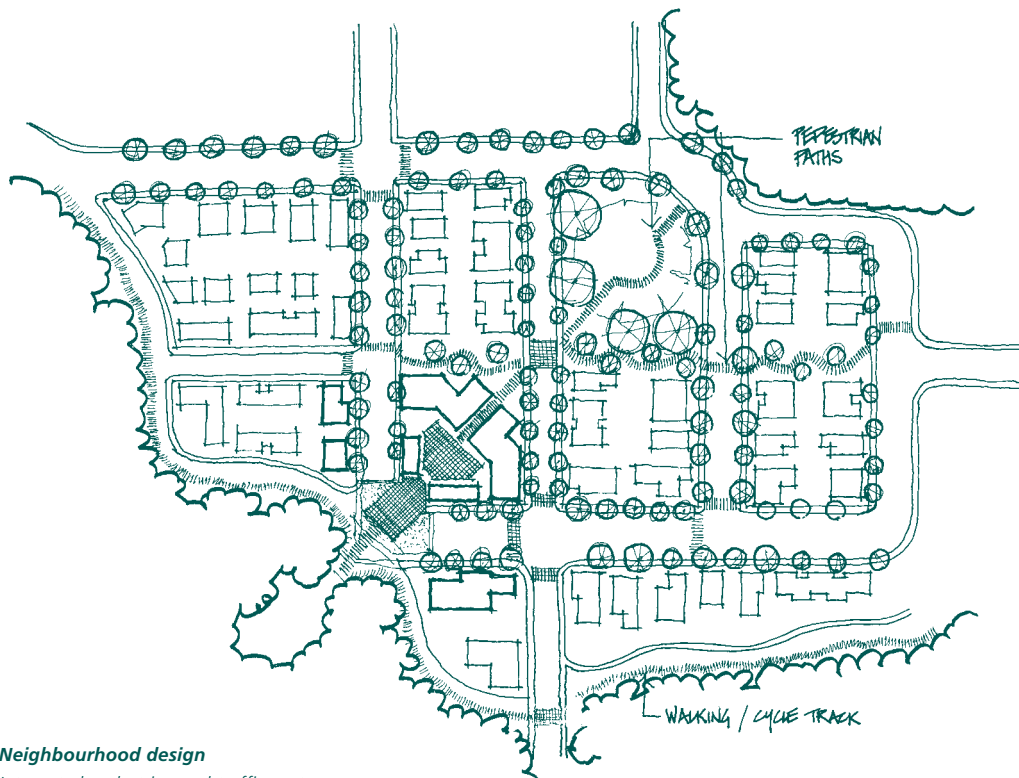

Figure 5: Neighbourhood design
Integrated pedestrian and traffic routes

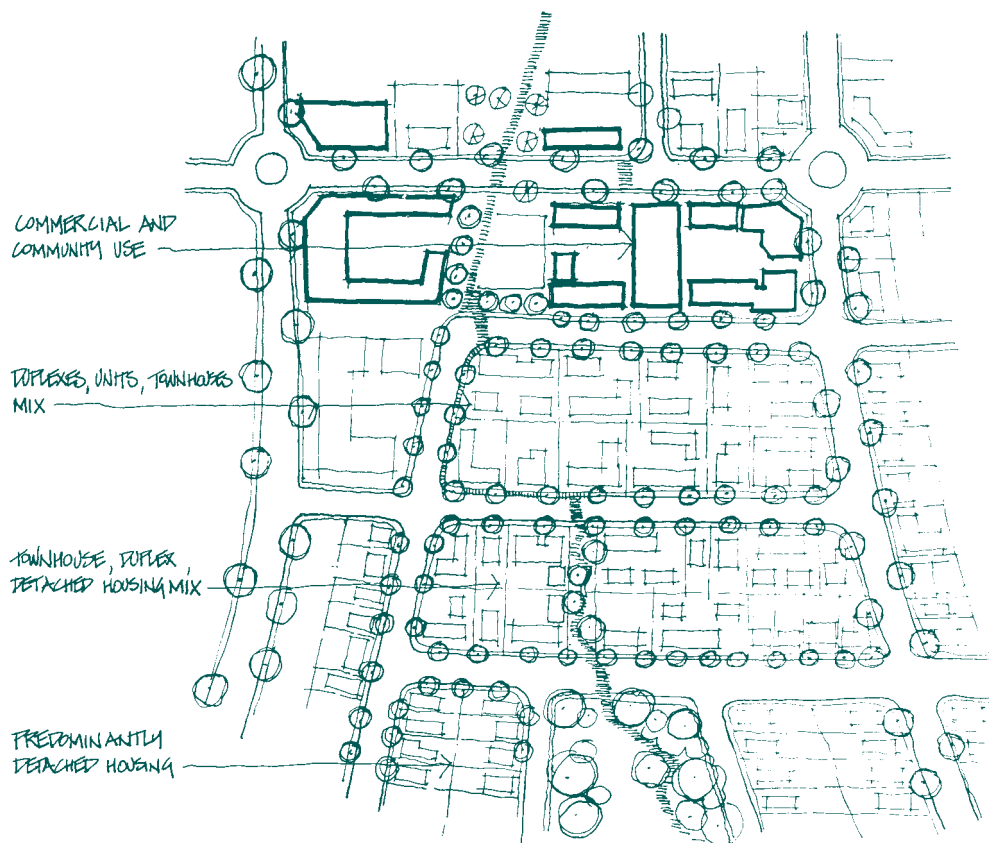

Figure 6: Neighbourhood design
Housing choice

ELEMENT A2

Street Networks

INTENT

To create street networks in which the function of each street is clearly identified, providing acceptable levels of access, safety and convenience for all users.

PERFORMANCE CRITERIA

The intent may be achieved where:

Function and structure

- P1** The street network has a clear structure and component streets conform to their function in the network.
- P2** The network has clear physical distinctions between each type of street. These distinctions are based on function, legibility, convenience, traffic volumes, vehicle speeds, public safety and amenity.
- P3** The design features of each type of residential street encourage driver behaviour appropriate to the primary function of the street in the network.

Safety, access and convenience

- P4** Junctions along residential streets are spaced to create safe and convenient vehicle movements.
- P5** The street network creates convenient movement for residents between their homes and higher-order roads.

Mode choice

- P6** The alignment and geometry of the streets that form identified bus routes allow for efficient and unimpeded movement of buses without facilitating high traffic speeds.
- P7** The street network facilitates walking and cycling within the neighbourhood and to local activity centres.

ACCEPTABLE SOLUTIONS

The Acceptable Solutions illustrate ONE WAY of meeting the associated Performance Criteria.

A defined street network plan exists which indicates the street network below the level of major collector street and development conforms with this plan.

OR

Where no defined street network plan exists development conforms with *Queensland Streets*.

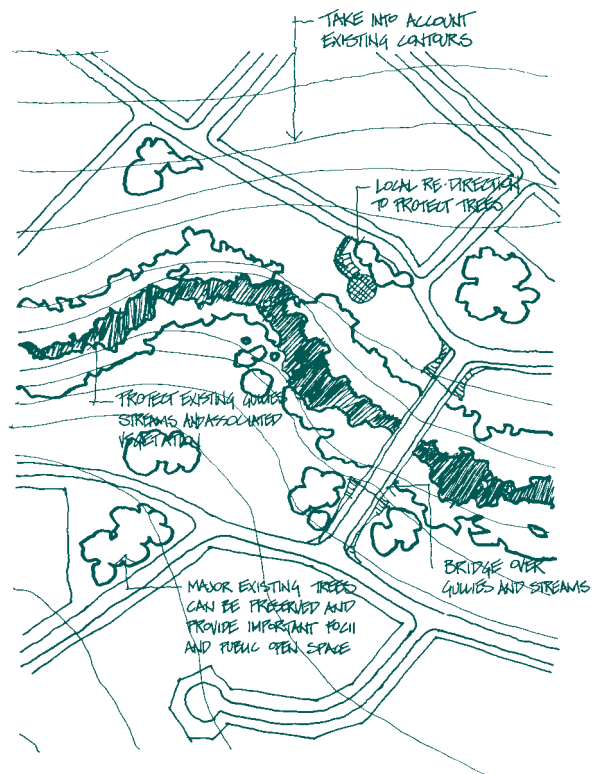

Figure 7: Street network designed to suit the site

ELEMENT A 2

Street Networks continued

PERFORMANCE CRITERIA

Urban design and character

- P8** The street network takes account of the topography and vegetation, respects any existing or potential site assets, and takes advantage of opportunities for views and vistas.
- P9** The street network takes account of the streetscapes that may be created or that already exist.
- P10** The street network is orientated, where practical, to promote efficient solar access for dwellings.
- P11** The street network takes account of natural drainage and open space systems.

Environmental protection

- P12** Traffic generated by a development is within the acceptable environmental capacity of the roads and streets.
- P13** Streets do not operate as through-traffic routes for externally-generated traffic, while limiting the length of time local drivers need to spend in a low-speed environment.
- P14** The street network is designed to reduce traffic speeds and volumes to acceptable levels, with most dwellings fronting streets with low volumes.
- P15** The impact of measures intended to restrain traffic speeds and/or volumes take account of the needs of other street users and adjoining dwellings.

Cost-effectiveness

- P16** Streets and carriageway widths and street lengths optimise the cost-effectiveness of the street network.
- P17** The network provides for the cost effective provision of public utilities.

ACCEPTABLE SOLUTIONS

ELEMENT A3

Public Open Space

INTENT

To provide, where appropriate, public open space that meets user requirements for outdoor recreational and social activities and for landscaping that contributes to the identity and environmental health of the community.

PERFORMANCE CRITERIA

The intent may be achieved where:

- P1** The multi-functional role of public open space, and its use as a community facility and for stormwater management, is recognised and promoted.
- P2** Public open space provides:
- a range of recreation settings, corridors for community paths, and attractive urban environment settings and focal points;
 - adequate facilities to meet the needs of the community as reflected by indicators such as population density and demographic structure;
 - accessibility to users in conjunction with existing facilities;

ACCEPTABLE SOLUTIONS

The Acceptable Solutions illustrate ONE WAY of meeting the associated Performance Criteria.

(in relation to P1 and P2)

- A1.1** Public open space is provided in accordance with an approved open space strategy, neighbourhood plan or development plan.

OR

(in partial satisfaction of P1 and P2)

- A1.2** Areas of public open space (incorporating drainage networks designed as part of multiple-use drainage systems) are provided to meet the statutory requirements of State and local authorities.

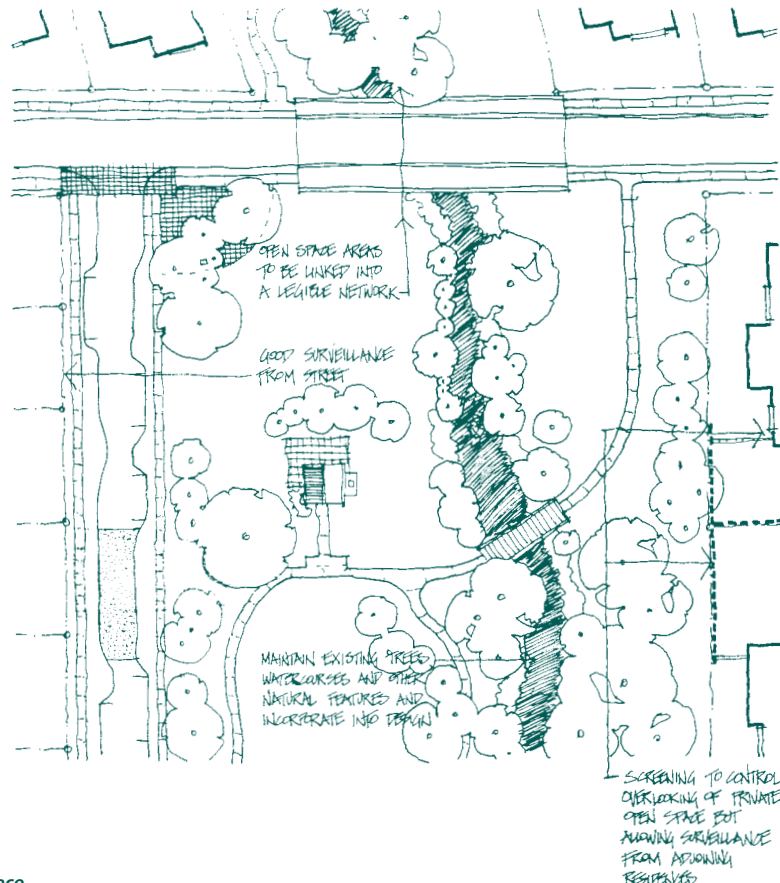

Figure 8: Public open space

ELEMENT A 3

Public Open Space continued

PERFORMANCE CRITERIA

- acknowledgement of the opportunities and constraints presented by the physical characteristics of the land in the proposed use, landscaping and facilities;
- opportunities for the incorporation of existing trees, rocks, streams and other sites of natural or cultural value, and linkage of habitats and wildlife corridors;
- opportunities to link public open spaces into a legible network;
- public safety and reasonable amenity of adjoining land users in the design of facilities and associated engineering works;
- for proposed responsibilities, maintenance requirements and costs;
- opportunities for regional or district open space to meet neighbourhood open space requirements;
- a clear relationship between public open space and adjoining land uses established by appropriate treatment including alignment, fencing, landscaping, and issues of security and surveillance; and
- avoidance of continual lengths of solid fencing along open space areas for security, surveillance, aesthetic and maintenance reasons.

ACCEPTABLE SOLUTIONS

ELEMENT A 4

Street Design

INTENT

To provide for streets that fulfil their designated functions within the street network, accommodate public utility services and drainage systems, and create a safe and attractive environment.

PERFORMANCE CRITERIA

The intent may be achieved where:

Function and width

- P1** The design features of each type of residential street convey its primary function.
- P2** The street reserve width is sufficient to cater for all street functions, including:
- safe and efficient movement of all users;
 - provision for parked vehicles;
 - provision of landscaping;
 - location, construction and maintenance of public utilities.
- P3** The verge width is sufficient to provide for special site conditions and future requirements.

Designing for safety

- P4** The design facilitates safe use by pedestrians, particularly people with disabilities, the aged and children, by:
- providing a carriageway width which allows vehicles to proceed safely at the operating speed intended for that level of street;
 - making allowances for restrictions caused by on-street parking;
 - providing a horizontal and vertical alignment which is not conducive to excessive speeds;
 - promoting the safety of pedestrians where it is intended that they use the carriageway at bus stops and other crossing points;
 - promoting the safety of cyclists in streets and at crossings points.

ACCEPTABLE SOLUTIONS

The Acceptable Solutions illustrate ONE WAY of meeting the associated Performance Criteria.

Development conforms with the provisions of Queensland Streets.

ELEMENT A 4

Street Design continued

PERFORMANCE CRITERIA

Designing for safety (continued)

P5 Speed reduction techniques and devices are used to achieve desired speeds, as part of a design for the whole street environment, and include the following principles:

- slow points including either horizontal or vertical deflection are designed to slow traffic to design speeds;
- slow points and carriageway narrowings are designed to take into account the needs of cyclists, by ensuring speed compatibility, adequate space for concurrent passage or off-street diversions;
- landscape design, on-street parking and streetscape design are used to complement speed restriction measures;
- speed restriction techniques and devices are not used in isolation;
- the verge, when considered in conjunction with the horizontal alignment and permitted fence, wall and other property frontage treatments, provides safe sight distances, taking into account expected vehicle speeds and pedestrian and cyclist movements.

P6 Safe sight distances, based on the speeds at which vehicles may travel in the street, exist at access points to properties, pedestrian and cyclist crossings and at junctions and intersections.

Access and verge

P7 The carriageway width, together with the verge width and crossover dimensions, allows for unobstructed and efficient access to individual lots and sites, even when a car is parked on the opposite side of the street.

P8 Driveway egress movements do not create a safety hazard.

ACCEPTABLE SOLUTIONS

ELEMENT A 4

Street Design continued

PERFORMANCE CRITERIA

Geometric design

- P9** Bus routes have a carriageway width to allow for the movement of buses unimpeded by parked cars, safely accommodate cyclists and avoid cars overtaking parked buses.
- P10** The horizontal and vertical alignments and crossfall reflect physical land characteristics and major drainage functions, while satisfying safety criteria.
- P11** Geometric design for intersections, roundabouts and slow points is consistent with the vehicle speed intended for each street.
- P12** Kerb radii at intersections and junctions are kept to a minimum, subject to satisfying required turning templates (including those for service and emergency vehicles), to keep pedestrian crossing distances to a minimum and to control the speeds of turning vehicles.
- P13** Siting conditions on land abutting major collector streets ensure that all vehicles can enter or leave the street in a forward direction.

On-street parking

- P14** Resident and visitor carparking is provided according to projected needs taking into account:
- total parking demand;
 - parking opportunities within allotments; and
 - non-residential and external parking generators.
- P15** Parking provision shall be designed to ensure:
- no obstruction or danger to the passage of vehicles on the carriageway, or to pedestrians;
 - efficient design of parking spaces and accesses; and
 - convenient vehicle access to allotments.

ACCEPTABLE SOLUTIONS

ELEMENT A4

Street Design *continued*

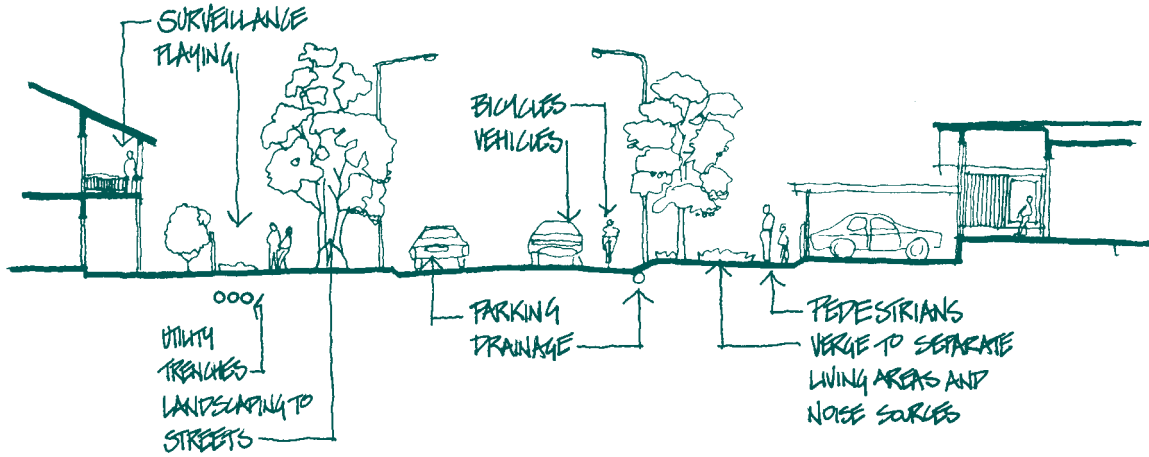

Figure 9: Typical street cross section

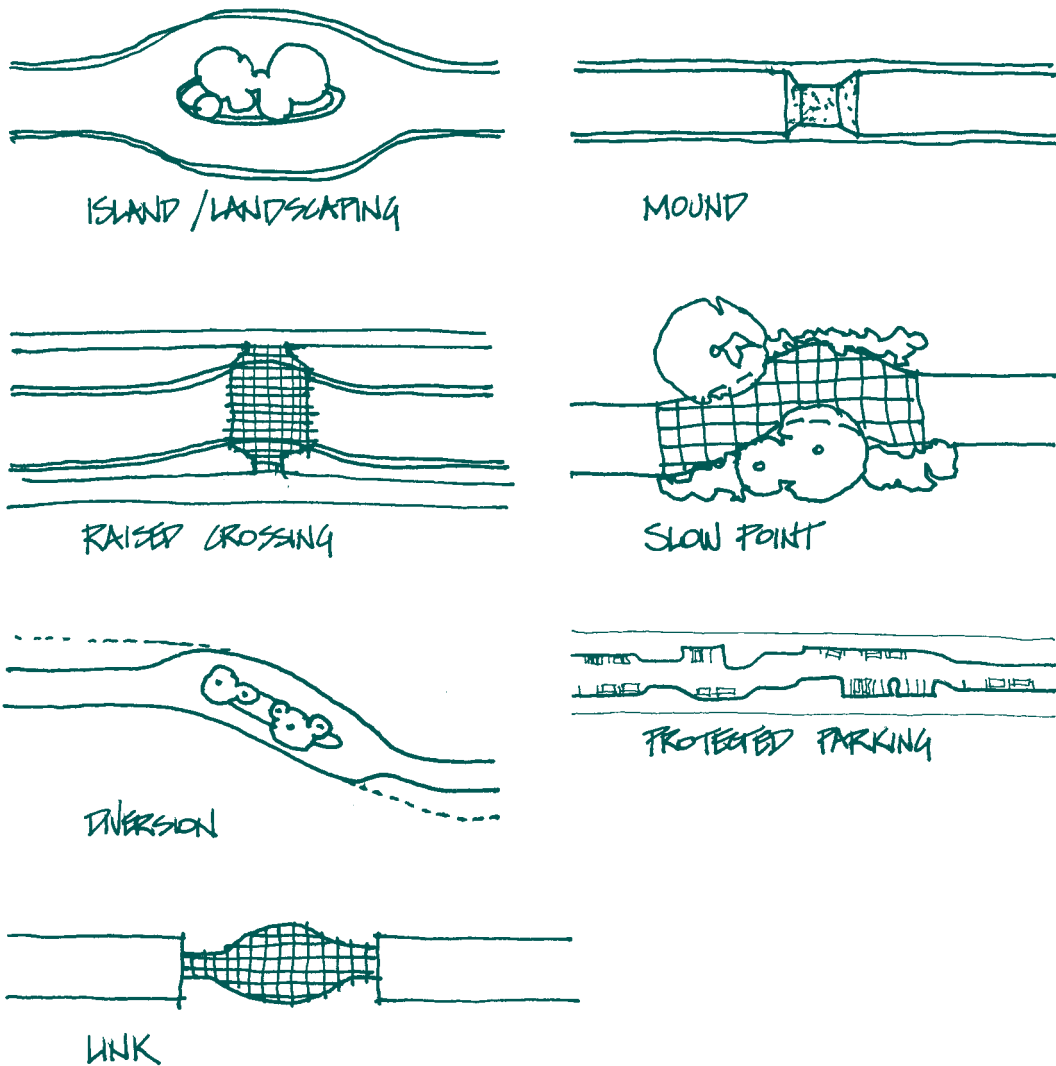

Figure 10: Speed reduction by various means

ELEMENT A 5

Street Construction

INTENT

To construct streets that support the design intentions without unnecessary construction and whole-of-life-cycle costs.

PERFORMANCE CRITERIA

The intent may be achieved where:

- P1** The pavement, edging and landscaping support the specified functions and amenity of the street.
- P2** The pavement edge:
- controls vehicle movements by delineating the carriageway for all users where applicable;
 - assists in reducing stormwater run-off into the reticulated system, by conveying stormwater to a desired outlet;
 - provides for people with disabilities, by allowing safe passage of wheelchairs and other mobility aids.
- P3** Street pavement surfaces are well designed and durable enough to carry wheel loads of travelling and parked vehicles; ensure the safe passage of vehicles, pedestrians and cyclists; the discharge of stormwater runoff, and the preservation of all-weather access; and allow for reasonable travel comfort.
- P4** Consistent with the previous Performance Criteria, public street construction and whole-of-life-cycle costs are kept low.

ACCEPTABLE SOLUTIONS

The Acceptable Solutions illustrate ONE WAY of meeting the associated Performance Criteria.

- A1** Pavement and landscape materials are used, where appropriate, to distinguish different street functions.
(in partial satisfaction of P2)
- A2** Pavement edges at locations where pedestrians are encouraged to cross, are constructed for wheelchair access and to assist sight-impaired people in accordance with AS1428.
- A4.1** Flexible pavement construction is based on the ARRB residential street pavement design method using equivalent standard axle loadings and a 20-year design life (ARRB, 1989).
- AND
- A4.2** Concrete pavement construction is based on the Cement and Concrete Association of Australia's design table, and interlocking block pavement construction is based on the ARRB interlocking block pavement design method.
- A4.3** Kerb and channel profiles accord with AS 2876-1987 or as specified by the relevant authorities.

ELEMENT A 6

Utilities

INTENT

To ensure that residential areas are adequately serviced with sewerage, water fire-fighting, electricity, gas, street lighting and communication services in a timely, cost-effective, coordinated and efficient manner that supports sustainable development practices.

PERFORMANCE CRITERIA

The intent may be achieved where:

- P1** The design and provision of public utilities, including sewerage, water, electricity, gas, street lighting, and communication services, are cost-effective over their life cycle and incorporate provisions to minimise adverse environmental impact in the short and long term.
- P2** Compatible public utility services are co-located in common trenching in order to minimise the land required and the costs for underground services.
- P3** Transportation, treatment and disposal of sewage wastes are to the satisfaction of the local authority or relevant servicing authority, and the relevant environmental regulator.
- P4** Development occurs within locations where there is an adequate water supply for domestic and fire fighting purposes.
- P5** Development is staged to ensure that each stage is fully serviced before a new area is released.
- P6** Water supply and sewerage networks are accessible, easy to maintain, and cost-effective based on life-cycle costs.
- P7** The selection of materials used for the construction of water supply and sewerage networks is determined by suitability, durability, ease of maintenance and cost-effectiveness considering whole-of-life-cycle costing, achieving beneficial environmental impacts/energy savings etc from new materials and technologies.
- P8** Adequate buffers are maintained between utilities and houses to protect residential amenity and health.
- P9** The use of local effluent treatment plants to recycle and reuse waste is achieved in areas where connections to large sewage treatment plants are less economically viable.

ACCEPTABLE SOLUTIONS

The Acceptable Solutions illustrate ONE WAY of meeting the associated Performance Criteria.

(in relation to P1 to P9)

- A1.1** The location, design and proposed construction of sewerage facilities, water supply mains and fixtures, electricity, gas, communication services and street lighting are in accordance with a development plan.
- OR
- A1.2** The design and provision of public utilities, including sewerage, water, electricity, gas, street lighting and communication services conform to the cost-effective and environmental performance measures of the relevant servicing authorities.
- AND
- A1.3** The design and construction of sewerage facilities, water supply mains and fixtures, electricity, communications, gas and street lighting are undertaken by properly qualified personnel.
- AND
- A1.4** The distribution system for all services will be in place before the first houses are occupied.

ELEMENT A 6

Utilities continued

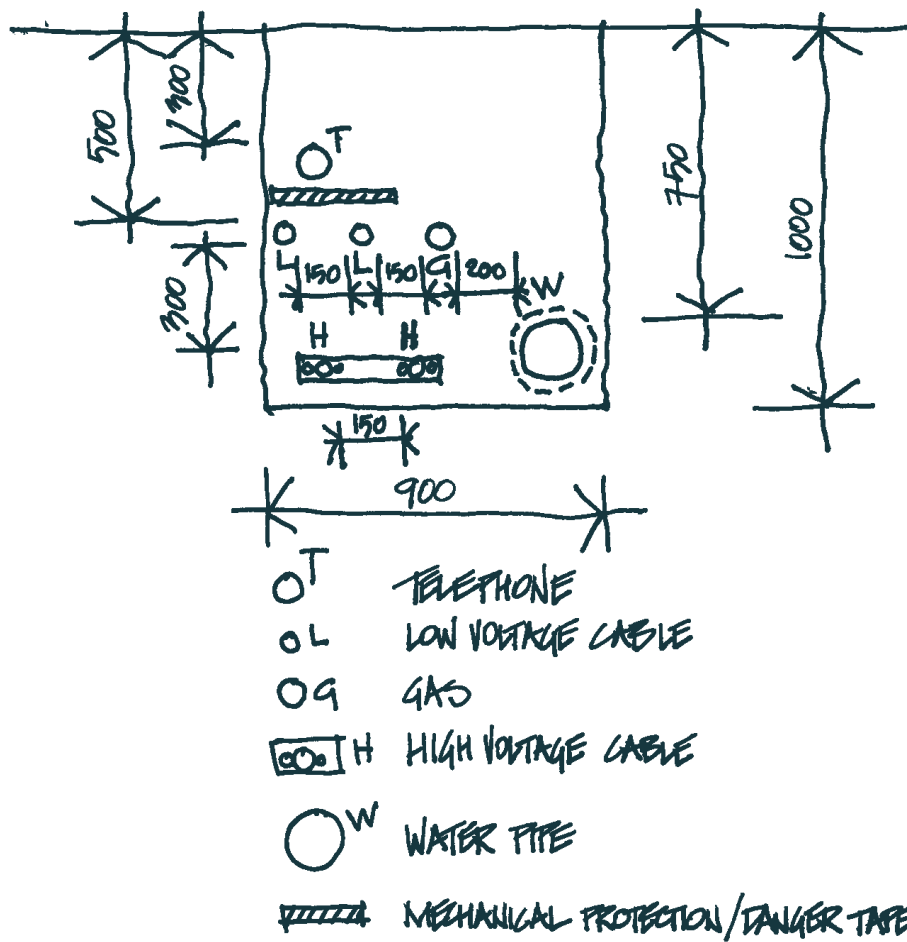

Figure 11: Common trenching

ELEMENT A 7

Storm Drainage

INTENT

To provide storm drainage systems which adequately protect people and the natural and built environments at an acceptable level of risk and in a cost-effective manner, in terms of initial cost and maintenance, and which contribute positively to environmental enhancement of catchment areas.

PERFORMANCE CRITERIA

The intent may be achieved where:

Roof Drainage

P1 The roof drainage system has the capacity to control stormwater flows under normal operating conditions for the relevant design storm:

- which prevents the flow of stormwater from the guttering into the dwelling;
- which does not concentrate or re-direct stormwater onto adjoining properties.

P2 Design of the roof and site drainage system is such that it can be economically maintained with a reduced risk of blockages.

Site Drainage

P3 The site drainage system has the capacity to control surface stormwater flows from the site and any excess flows from upstream properties to prevent stormwater flows from entering the dwelling in the design event.

P4 The ground-floor level of the dwelling is located above the site surface level to an extent which prevents entry of stormwater flows into the dwelling in accordance with an acceptable level of risk.

P5 The site drainage system minimises undesirable ponding for a prolonged period.

P6 Design of the site drainage system provides for on-site infiltration if soil conditions are suitable.

P7 Adequate provision is made for measures during construction to ensure that the land form is stabilised and erosion is controlled.

ACCEPTABLE SOLUTIONS

The Acceptable Solutions illustrate ONE WAY of meeting the associated Performance Criteria.

A1 The roof drainage system is designed for a rainfall intensity derived for the area in which the design is proposed based on ARI = 20 years, 5 minutes duration.

A2 Leaf guards fitted to guttering at downpipes. Clean out points provided on underground pipe systems.

A3.1 Where the topography of the site makes it necessary to discharge stormwater run-off to the rear of the site, the run-off from all directly connected impervious areas (roof and paved areas) shall be to an inter-allotment drainage system (to the requirements of QUDM);

AND

A3.2 The site slopes away from the dwelling (50mm at 1000mm from dwelling).

A4 Compliance with the BCA requirements for minimum floor heights.

A5 Provide for no area to pond to a depth greater than 50mm within one hour following rainfall.

A6 If soil conditions are suitable, soakage chamber installed within property with overflow via inter-allotment drainage system.

A7 Site erosion prevention details are provided as per industry code of practice.

ELEMENT A 7

Storm Drainage continued

PERFORMANCE CRITERIA

Road and Pathway and Open Space Drainage

Major system

- P8** The major storm drainage system has the capacity to safely convey stormwater flows result from the relevant design storm under normal operating conditions.
- P9** The major system has the capacity to convey safely, but without significant property damage, stormwater flows resulting from more extreme events than its design storm.
- P10** Ground-floor levels of proposed dwellings can be located above the design flood level to provide protection of property in accordance with the accepted level of risk.
- P11** Floodways are developed such that there is a low risk of property damage.
- P12** The major system is designed to ensure that there are no flow paths which would increase risk to public safety and property.
- P13** Community benefit is maximised through the retention of natural streams and vegetation wherever practicable, the incorporation of sports grounds and other less flood-sensitive land uses into the drainage corridor and the placement of detention and retention basins for amenity and function.

ACCEPTABLE SOLUTIONS

Major system

(in relation to P8 to P13)

- A8** The design and construction of the major storm drainage system are in accordance with a plan of development and the requirements of the relevant authorities.

OR

Development conforms with the provisions of Queensland Urban Drainage Manual except that:

- a) the major system has the capacity to safely convey stormwater flows under normal operating conditions and partial minor system blockage for ARI = 50 years.
- b) Flows within the street are limited in depth and velocity by the formula

$d_g V$ is \leq or = $0.9m^2/S$

for longitudinal flow

$d_g V$ is \leq or = $0.6m^2/S$

for cross flow where a vehicle is likely to be washed off the roadway into the drainage system

$d_g V$ is \leq or = $0.4m^2/S$

for cross flow where a pedestrian is likely to be washed into the drainage system

[where d_g = kerbside flowdepth (m)]

ELEMENT A 7

Storm Drainage continued

PERFORMANCE CRITERIA

Minor system

- P14** The minor storm drainage system has the capacity to control stormwater flows under normal operating conditions for the relevant design storm without blockage.
- P15** Drainage networks are well-defined to ensure there are no hidden flow paths which could reduce their capacity to convey design flows.
- P16** The minor system design minimises undesirable ponding for a prolonged period resulting from the relevant design storm.
- P17** The design of the minor system takes full account of existing downstream systems.
- P18** The minor system design allows for the safe passage of vehicles at reduced speed on streets which have been affected by runoff from the relevant design storm.
- P19** The minor system is accessible and easily maintained.
- P20** Where a portion of the minor system lies within a site, access is available for maintenance.
- P21** The selection of materials used for the construction of the minor system is based on their suitability, durability, maintainability and cost-effectiveness.

ACCEPTABLE SOLUTIONS

Minor system

(in relation to P14 to P21)

- A14** The design and construction of the minor system is in accordance with a plan of development and the requirements of the relevant authorities.

OR

(in relation to P14 to P17)

Development conforms with the provisions of the Queensland Urban Drainage Manual.

ELEMENT A 8

Water Quality Management

INTENT

To provide water quality management systems which ensure that disturbance to natural stream systems is minimised and stormwater discharge to surface and underground receiving waters, both during construction and in developed catchments, does not degrade the quality of water in the receiving domains.

PERFORMANCE CRITERIA

The intent may be achieved where:

- P1** Adequate provision is made for measures during construction to ensure that the land form is stabilised and erosion is controlled.
- P2** The system design optimises the interception, retention and removal of water-borne pollutants through the use of appropriate 'fitness for use' criteria, prior to their discharge to receiving waters.
- P3** The system design minimises the environmental impact of urban run-off on surface receiving water quality and on other aspects of the natural environment, such as creek configuration and existing vegetation, by employing all possible techniques which are technically appropriate and effective in reducing run-off and pollution travel in the catchment.
- P4** The system design minimises the environmental impact of urban run-off, diverted underground, on groundwater quality.
- P5** The system design ensures the continuation, in healthy condition, of a wide diversity of wetland environments in the urban landscape.
- P6** Sewage overflows into the stormwater system are prevented.
- P7** Point sources of pollution in the catchment should be identified and their impact minimised until they can be eliminated.

ACCEPTABLE SOLUTIONS

The Acceptable Solutions illustrate ONE WAY of meeting the associated Performance Criteria.

(in relation to P1 to P7)

- A1.1** The design and proposed implementation of the water quality control system are in accordance with a development plan and the requirements of the relevant authorities.

OR

(in partial satisfaction of P1 to P7)

- A1.2** The full range of appropriate practices and devices reviewed in Planning and Management Guidelines for Water-sensitive Urban (Residential) Design (Whelans et al. 1994) are addressed.

AND

- A1.3** The design of the water pollution minimisation system is undertaken and certified by properly qualified personnel using recognised and locally accepted hydrologic, hydraulic, hydrogeological, soils, water quality and biological data and design methodologies.
- A1.4** Water pollution control ponds or wetlands should be developed (where appropriate) for final treatment before discharge to the wider environment and should be sited to minimise impacts on the natural environment.

AND

- A1.5** Appropriate water quality criteria in accordance with 'fitness for use' requirements should be applied to all stormwater diverted underground to recharge aquifers.

AND

- A1.6** Litter reduction education programs, frequent street sweeping and regular pit cleaning operations should be carried out.

ELEMENT A 9

Lot Layout

INTENT

To provide a range and mix of lot sizes to suit a variety of dwelling and household types, with areas and dimensions that meet user requirements; and to provide lots that are oriented where practicable to enable microclimate management, including the application of energy conservation principles.

PERFORMANCE CRITERIA

The intent may be achieved where:

Size

- P1** Lots have the appropriate area and dimensions for the siting and construction of a dwelling and ancillary outbuildings, the provision of private outdoor space, convenient vehicle access and parking.
- P2** Lot size and dimensions take into account the slope of the land and the desirability of minimising earthworks/retaining walls associated with dwelling construction.
- P3** Lot size and dimensions enable dwellings to be sited to:
- protect specified natural or cultural features;
 - acknowledge site constraints including soil erosion and bushfire risk;
 - retain special features such as trees and views where practical.
- P4** Lot sizes meet the projected requirements of people with different housing needs, and provide housing diversity and choice.

User requirements

- P5** Lot frontages are orientated to streets and open spaces so that personal and property security, deterrence of crime and vandalism, and surveillance of footpaths and public open space are facilitated.

Orientation and energy

- P6** Lots are orientated to facilitate the siting of dwellings to take advantage of microclimatic benefits, and have dimensions to allow adequate on-site solar access and access to breezes (especially in the hot-humid tropics), taking into account likely dwelling size and the relationship of each lot to the street.

ACCEPTABLE SOLUTIONS

The Acceptable Solutions illustrate ONE WAY of meeting the associated Performance Criteria:

Size

(in partial satisfaction of P1)

- A1.1** Lots with an area of greater than 450m² are capable of containing a rectangle measuring 10m by 15m behind the street setback (or 9m by 15m where a boundary wall is nominated as part of the building envelope).
- AND
- A1.2** Lots with an area between 300m² and 450m² are capable of containing a rectangle measuring 9m by 15m behind the street set back.
- AND
- A1.3** Lots with an area less than 300m² are square or rectilinear in shape.
- AND
- A1.4** For "battleaxe" lots, the access way shall be a minimum of 4m wide. The rear lot area and dimensions, exclusive of the access way satisfies A1.1 or A1.2 or A1.3. (Where adjoining "battleaxe" lots occur, joint use of a single driveway is an acceptable cost-effective solution).

(In partial satisfaction of P2)

- A2** Lots with an area of 450m² or less are located on land with a slope of less than 1 in 10 across the road frontage of the lot and 1 in 15 perpendicular to the road frontage.

ELEMENT A10

Street Setbacks

INTENT

To setback buildings and garages/carports from the street to provide adequate space for landscape or open space, visual and acoustic privacy and vehicle parking, while assisting in establishing an attractive streetscape.

PERFORMANCE CRITERIA

The intent may be achieved where:

- P1** The setback of buildings makes efficient use of the site and provides amenity for residents.

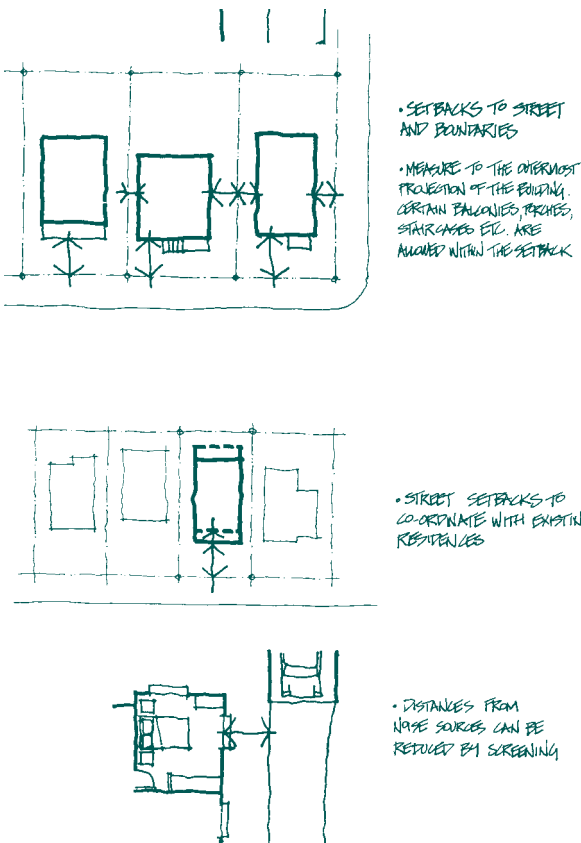

Figure 12: Street / noise source setbacks

ACCEPTABLE SOLUTIONS

- A1.1** A Streetscape Concept Plan and/or Landscape Plan is submitted that demonstrates how the Performance Criteria are met.
- OR
- A1.2** In areas being urbanised or newly-developed areas, setbacks (inclusive of any verandah, porch etc) from the street boundary should be as follows:

TABLE 1: Street setbacks in new areas¹

Street type	Minimum frontage setback (m)	Minimum side setback to corner street (m)
Access Place and Access Street	3.0	1.0
Collector Street	4.0	2.0

¹ The setback may be averaged, providing no part of the building is setback less than 2m.

- A1.3** In established areas where the setback of an adjacent building is greater than 3m, the minimum street setback of infill development is to be the lesser of:
 - the setback specified in the Standard Building Law; and
 - the same distance as one or the other of the adjoining buildings, provided the difference between the setbacks of the two adjoining buildings is less than or equal to 2m; or
 - the average of the setbacks of the adjoining dwellings, if the difference between the setbacks of the adjoining buildings is greater than 2m.

ELEMENT A 10

Street Setbacks continued

PERFORMANCE CRITERIA

ACCEPTABLE SOLUTIONS

- A1.4** In established areas where the setbacks of adjacent buildings are 0–3m, infill development is to be setback the same distance as one or the other of the adjoining dwellings.
- A1.5** Setback of buildings in significant urban conservation and heritage streetscapes shall generally match with that of adjacent development unless an alternative policy has been developed for that street.
- A1.6** Walls of dwellings incorporating a habitable room to be setback a minimum of 1.5m from shared driveways, communal streets and visitor carparks. This setback may be reduced if suitable privacy screening and/or acoustic treatment to the dwelling walls is provided.
- A1.7** Single garages/carports associated with dwellings for which more than one on-site parking space is required are to be setback from the public street frontage a minimum of 5.5m;
- A1.8** Single garages/carports associated with dwellings for which more than one on-site parking space is required are to be setback from a corner or secondary street frontage a minimum of 5.5m.
- A1.9** Double garages/carports are setback from a corner or secondary street frontage to not less than half the setback to the street of any existing adjacent dwelling that faces the secondary street, provided that the setback is not less than that of the associated dwelling.

ELEMENT A 1 1

Building Envelope and Siting

INTENT

To enable flexibility in building siting while protecting reasonable neighbour amenity expectations, maintaining appropriate residential character and visual bulk, and providing adequate daylight to dwellings and sunlight to private open space.

PERFORMANCE CRITERIA

Building Envelope Setbacks

- P1** Setbacks are progressively increased as wall height increases to reduce bulk and overshadowing while maintaining adequate daylight and sunlight.
- P2** Building siting and height is related to land form, with minimal cut and fill.
- P3** Building bulk is generally distributed to reduce impact on neighbours and on the public street.
- P4** Building heights are similar to those in the public streetscape, with taller buildings sited so as to minimise adverse impacts on neighbours and on the streetscape.
- P5** Building forms enable a sharing of any longer views with neighbours.
- P6** Building to the boundary maximises privacy for neighbouring dwellings and their private open space.

ACCEPTABLE SOLUTIONS

The Acceptable Solutions illustrate ONE WAY of meeting the associated Performance Criteria.

Building Envelope and Setbacks

- A1.1** Where walls are not built to the boundary, side and rear setbacks shall comply with the Standard Building Law Part 9.

ELEMENT A 11

Building Envelope and Siting continued

PERFORMANCE CRITERIA

- P7** Boundary walls are limited in length and height, to minimise the impact on neighbours.

ACCEPTABLE SOLUTIONS

- A7.1** Walls built to side boundaries have:
- an average height of 3.0m
 - a maximum height of 3.5m, unless they;
 - abut a higher existing or simultaneously constructed wall;
 - are in accord with an approved building envelope plan;
 - abut a side or rear lane (in which case the maximum height shall be 5.5m).
- AND
- A7.2** Where there are no existing boundary walls, the maximum boundary wall length is 15 metres.
- OR
- A7.3** The length of new boundary walls matches the length of existing boundary walls.
- OR
- A7.4** In areas where it has been determined to provide for an increase in development built to boundaries, the length of new boundary walls is limited to:
- 50% of the length of the adjacent side boundary;
- OR
- the length of existing boundary walls plus 50% of the length of the remaining boundary.
- OR
- A7.5** In areas characterised by buildings with boundary walls extending for the full length of adjacent side street or rear lane boundaries, new boundary walls can extend for the full length of adjacent side street or rear lane boundaries.
- OR

ELEMENT A 1 1

Building Envelope and Siting continued

PERFORMANCE CRITERIA

- P8** Buildings are sited and designed to provide adequate daylight to habitable rooms.

ACCEPTABLE SOLUTIONS

Daylight and Sunlight

- A7.6** Where slope or retaining walls or fences would result in the effective height of a boundary wall being less than 2m on the adjacent property boundary, the new boundary wall can extend the full length of the side or rear boundary less any front boundary setback distance.
- A8.1** Habitable rooms in dwellings have clear windows in compliance with BCA requirements.

ELEMENT A 12

On-site Carparking and Access

INTENT

To ensure adequate provision of secure and accessible on-site parking for residents and visitors.

PERFORMANCE CRITERIA

The intent may be achieved where:

Parking provision

P1 Carparking is provided according to projected needs which are determined by:

- the number and size of proposed dwellings;
- availability of public transport;
- the availability of on-street carparking;
- locations of non-residential uses such as schools and local shops;
- the possible demand for carparking space from adjoining localities;
- the occasional need for overflow parking;
- the carparking requirements of people of differing socio-economic status, age, cultural background and differing stages of family life cycle.

Design

P2 Carparking facilities are designed and located to:

- conveniently and safely serve users, including pedestrians, cyclists and vehicles;
- enable efficient use of car spaces and accessways, including adequate manoeuvrability for vehicles between the street and the lot;
- fit in with any adopted street network hierarchy and objectives of the hierarchy, and with any related local traffic management plans;
- be cost-effective;
- achieve relevant streetscape objectives.

ACCEPTABLE SOLUTIONS

The Acceptable Solutions illustrate ONE WAY of meeting the associated Performance Criteria.

Parking provision

A1 The number of spaces provided is to comply with the following:

Dwelling Unit size or No. of bedrooms	Average spaces per dwelling*	
	A	B
Small or 1 bedroom < 75m ²	0.75	1.00
Medium or 2 bedroom 75m ² – 110m ²	1.00	1.50
Large or 3 + bedroom > 110m ²	1.25	2.00
Add for visitors per dwelling	0.25	0.25

* Round up to nearest whole number

Dwelling location
A < 400m from railway station, or bus stop
B any other circumstances.

Note: Development plans may identify areas in which a lesser provision may be appropriate, based on housing density, accessibility to public transport and employment areas, and other factors such as these.

ELEMENT A 12

On-site Carparking and Access continued

PERFORMANCE CRITERIA

Design (continued)

- P3** Carparking areas and accessways are designed, surfaced and sloped to facilitate stormwater infiltration on-site.
- P4** Open carparking areas and accessways are suitably landscaped to enhance amenity while providing for security needs of residents and visitors.

Construction

The intent may be achieved where:

- P5** The pavement, edging and landscaping support the specified functions and amenity of the street.
- P6** The pavement edge:
- controls vehicle movements by delineating the carriageway for all users;
 - assists in reducing stormwater run-off into the reticulated system, by conveying stormwater to a desired outlet or by providing for infiltration into subsoil;
 - provides for people with disabilities, by allowing safe passage of wheelchairs and other mobility aids.
- P7** Street pavement surfaces are well designed and durable enough to carry wheel loads of travelling and parked vehicles; ensure the safe passage of vehicles, pedestrians and cyclists; the discharge of rainfall, and the preservation of all-weather access; and allow for reasonable travel comfort.
- P8** Consistent with the previous Performance Criteria, street construction and whole-of-life-cycle costs are minimised.

ACCEPTABLE SOLUTIONS

Design

- A2.1** The dimensions of car spaces and access comply with the local planning scheme or a Plan of Development.
- A2.3** Access(es) of internal roadways to the public street system are located and designed in accordance with Queensland Streets, and any requirements of the Local Government (and/or the Department of Main Roads on a declared road).
- A2.4** Internal roadways are located to provide convenient connection between the public street, and all internal parking areas and service areas within the site.
- A2.5** Cul-de-sac roadways are avoided as far as possible.
- A2.6** Vehicles can turn within the site, to both enter from and exit to the public street in the forward direction.
- A2.7** The carriageway cross-section and geometry of roadways are in accordance with Queensland Streets recommendations for an Access Place or an Access Street as appropriate.
- A2.8** The widths and cross-section of roadway verges are sufficient to provide adequately for pedestrian footpaths (where required), utility services, and landscaping for visual amenity.
- A2.9** General minimum verge widths are 1.5m where no constructed footpath is required, or 2.5m where a footpath is required.
- A2.10** A separate constructed pedestrian footpath is provided where the "traffic catchment" of the roadway exceeds 40 dwelling units.
- A2.11** Separate footpaths are designed in accordance with Queensland Streets.

ELEMENT A 12

On-site Carparking and Access continued

PERFORMANCE CRITERIA

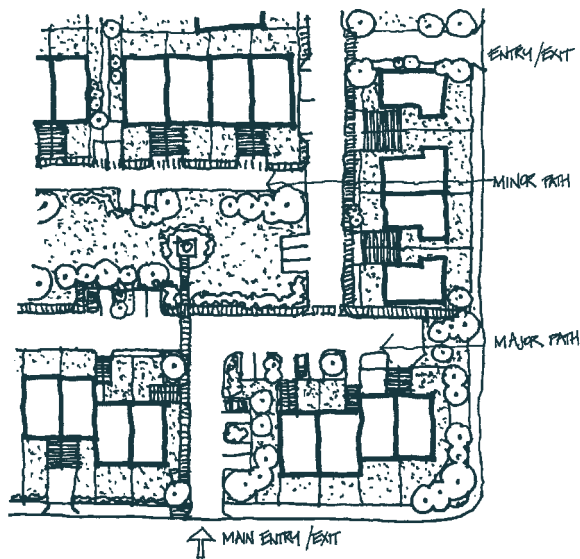

Figure 13: Integrated private and visitor carparking

ACCEPTABLE SOLUTIONS

- A2.12** Vehicle turning areas are provided at the end of cul-de-sac roadways, generally in accordance with the recommendations of Queensland Streets, but with geometry modified for the relevant refuse collection vehicle; except that for minor roadways, with maximum length 30m and providing access to a maximum of four units, the design vehicle may be a B99 car.
- A3** Open carparking spaces are surfaced with materials that provide for stormwater infiltration.
- A5** Pavement and landscape materials are used, where appropriate, to distinguish different street functions.
(in partial satisfaction of P6 to P8)
- A6** Pavement edges at locations where pedestrians are encouraged to cross, are constructed for wheelchair access and to assist sight-impaired people in accordance with AS1428.
- A8.1** Flexible pavement construction is based on the ARRB residential street pavement design method using equivalent standard axle loadings and a 20-year design life (ARRB, 1989).
- AND
- A8.2** Concrete pavement construction is based on the Cement and Concrete Association of Australia's design table, and interlocking block pavement construction is based on the ARRB interlocking block pavement design method.
- A8.3** Kerb and channel profiles accord with AS 2876-1987 or as specified by the relevant authorities.

ELEMENT A 13

Private Open Space

INTENT

To ensure that the private open space provided for dwellings is clearly defined, usable and meets user requirements for privacy, access, outdoor activities and landscaping.

PERFORMANCE CRITERIA

The intent may be achieved where:

- P1** Private open space is clearly defined for private use.
- P2** Private open space areas are of dimensions to suit the projected requirements of the dwelling occupants, and to accommodate some outdoor recreational needs, as well as providing space for service functions.
- P3** Part of the private open space is capable of serving as an extension of the dwelling for relaxation, dining, entertainment, recreation and children's play, and is accessible from a main living area of the dwelling.
- P4** Location of private open space takes advantage of outlook and natural features of the site; reduces adverse impact of adjacent buildings on privacy and overshadowing; and addresses surveillance, privacy and security issues where private open space abuts public space.
- P5** Orientation of private open space helps to achieve comfortable year-round use.

ACCEPTABLE SOLUTIONS

The Acceptable Solutions illustrate ONE WAY of meeting the associated Performance Criteria.

(in partial satisfaction of P1 to P3)

- A1.1** For developments with a site density of 40 dwellings per ha or less, private open space for the dwelling comprises:

(a) At-ground level :

- total minimum area of 20% of the site area (or average site area per dwelling for multi-dwelling developments), with a minimum dimension of 3.0m;
- one part with an area of 25m² with a minimum dimension of 4m and directly accessible from a living area of the dwelling;
- a maximum gradient of 1 in 10;
- screening provided where necessary to ensure privacy to users of the open space.

Note: A balcony or deck may be utilized as private open space where site gradients are excessive.

(b) At above-ground level :

- a balcony or rooftop area conveniently accessible from a main living area of the dwelling, having a minimum area of 10m² with a minimum dimension of 2m (2.5m in hot-humid and hot-arid climates);
- adequate screening to protect the privacy of neighbours (refer to Appendix Element C3).

OR

ELEMENT A 13

Private Open Space continued

PERFORMANCE CRITERIA

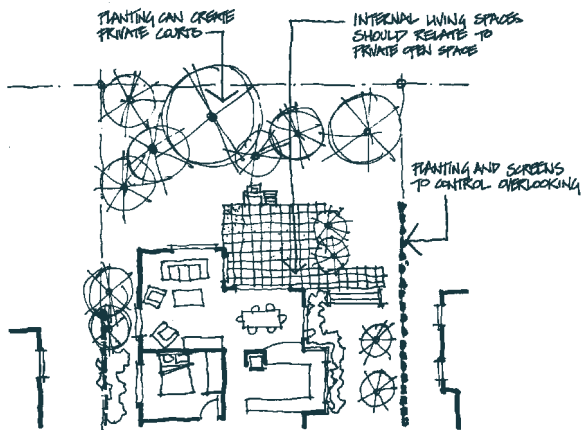

Figure 14: Private open space on larger lots



Figure 15: Small lot private open space

ACCEPTABLE SOLUTIONS

A1.2 For dwellings with a site density of more than 40 dwellings per ha, private open space for the dwelling comprises:

(a) At-ground level :

- total minimum area of 35m² (minimum 20% of site area for site densities greater than 60 dwellings per ha);
- a minimum dimension of 2.5m;
- a maximum gradient of 1 in 10;
- one part with an area of 16m² with a minimum dimension of 4m and directly accessible from a living area of the dwelling;
- screening provided where necessary to ensure privacy to users of the open space.

Note: A balcony or deck may be utilized as private open space where site gradients are excessive.

(b) At above-ground level:

- adequate screening to protect the privacy of neighbours (refer to Appendix Element C3);
- a balcony or rooftop area directly connected to the dwelling, having a minimum area of 8m² with a minimum dimension of 2m (2.5m in hot-humid and hot-arid climates).

ELEMENT A 1 4

Communal Open Space and Landscaping

INTENT

To ensure that any communal space provided for dwellings is clearly defined and usable, and helps create a pleasant, safe and attractive living environment.

PERFORMANCE CRITERIA

The intent may be achieved where:

- P1** Communal open space is designed according to projected user needs and is determined by: overall housing density; quality and extent of alternative private or nearby public open space; the need to distinguish communal open space clearly from private or public open space; type of activities envisaged; future maintenance and management requirements; the need to maintain the privacy of nearby dwellings; projected needs of children for outdoor play; the need for landscaping to enhance a sense of enclosure of communal open spaces, while allowing informal surveillance and meeting security needs; traffic implications; and hours of operation of communal facilities.
- P2** Unpaved or unsealed landscaped areas are maximised and are designed to facilitate on-site infiltration of stormwater run-off subject to soil/drainage conditions.
- P3** Major existing trees are retained wherever practicable through appropriate siting of dwellings and structures.
- P4** The landscape design specifies the location and species of trees, shrubs and ground cover in a way that:
- uses vegetation types and landscaping styles which blend the development into the streetscape;
 - does not adversely affect the structure of the proposed buildings;
 - contributes appropriate planting to streets fronted by the development;
 - considers personal safety, by ensuring good visibility along paths and driveways and avoiding shrubby landscaping near thoroughfares;

ACCEPTABLE SOLUTIONS

The Acceptable Solutions illustrate ONE WAY of meeting the associated Performance Criteria.

(in partial satisfaction of P1 to P8)

- A1** Landscaping shall be in accordance with an approved landscape plan for the site, certified by a qualified landscape architect or designer as meeting the Performance Criteria, and showing:
- the street reserve, carriageway, parking bays, footpaths, cycleway systems, street lighting and driveways;
 - existing vegetation and proposed general character of tree planting and landscape treatment (including proposed species and proposed means of ensuring the ongoing health and development of retained trees);
 - general arrangement of hard landscaping elements and major earth cuts, fills and mounding;
 - location and design of any communal recreation facilities, including methods of protecting the privacy of nearby dwellings;
 - clear delineation between communal and private areas of the site;
 - how informal surveillance of the communal open space can be achieved;
 - proposed irrigation and maintenance systems;
 - proposed lighting arrangement;
 - indicative treatment of any floodways and drainage lines, along with general information on fencing, access points, furniture and pavement style.

ELEMENT A 14

Communal Open Space and Landscaping continued

PERFORMANCE CRITERIA

- contributes to energy efficiency and amenity by providing substantial shade in summer, especially to west-facing windows and open carpark areas, and admitting winter sunlight to outdoor and indoor living areas (other than in the hot-humid and hot-arid climatic areas);
- improves privacy and minimises overlooking between dwellings;
- minimises risk of damage to overhead and underground power lines and other services;
- provides adequate sight lines for vehicles and pedestrians, especially near street corners and intersections.

- P5** Paving is provided to driveways, walkways, entries, outdoor patios and in the vicinity of garbage bin enclosures, letter boxes and clothes lines. Such paving should be:
- semi-porous or graded (i.e. gravels) to maximise on-site infiltration of stormwater (if practicable);
 - in materials and colours which complement the development and alternative adjoining streetscapes;
 - finished in non-slip surfaces;
 - suitable for use by people dependent on walking frames and wheelchairs.
- P6** Planting will not obscure or obstruct dwelling entries, paths and streets in a way that reduces the actual or perceived personal safety and security of residents and other pedestrians.
- P7** Lighting is provided to pedestrian ways, dwelling entries, driveways and carparks to ensure a high level of safety and security for residents and visitors at night.
- P8** Requirements for maintenance meet the needs of the owners and proposed management of the landscaped area.

ACCEPTABLE SOLUTIONS

ELEMENT A 14

Communal Open Space and Landscaping *continued*

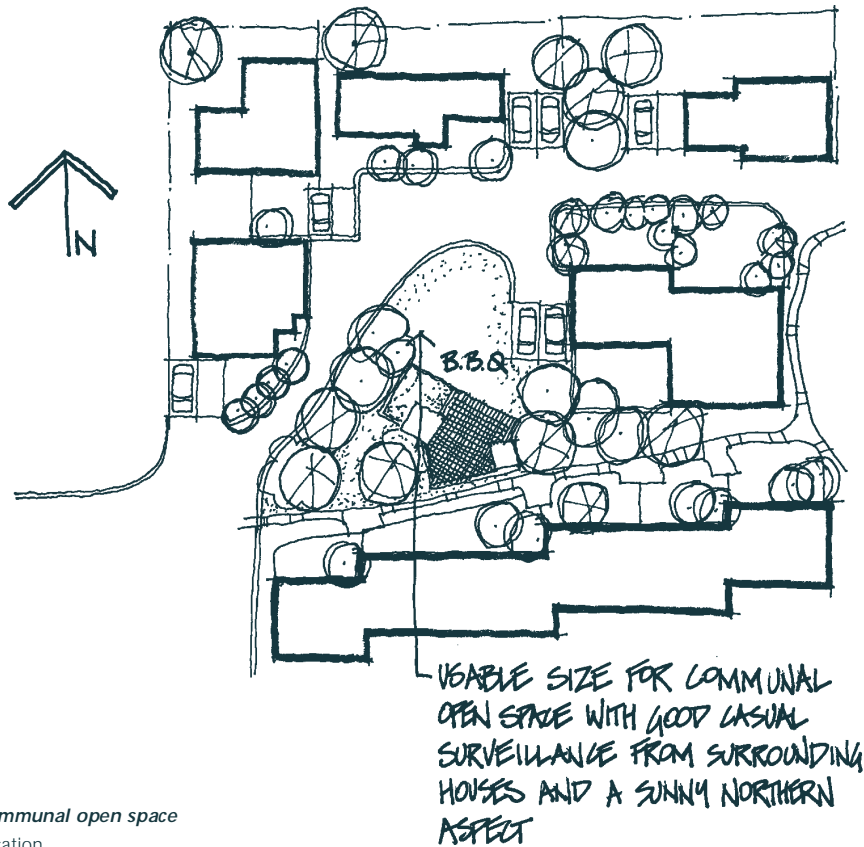

Figure 16: Communal open space Location

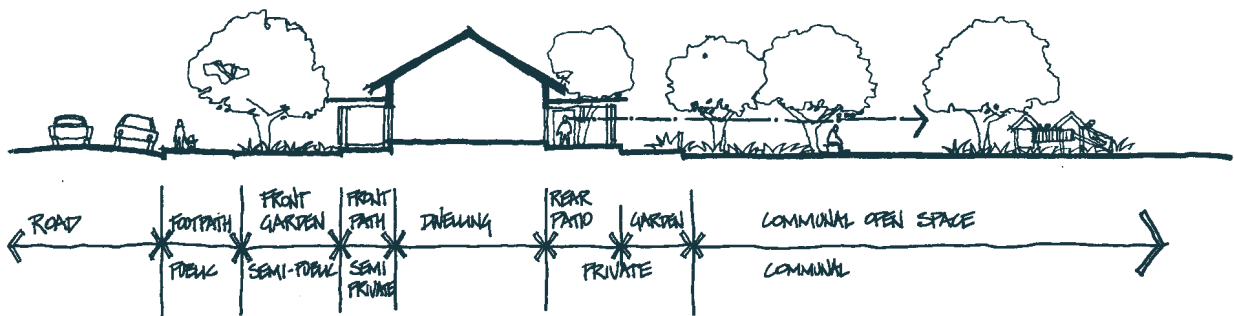

Figure 17: Communal open space Typical relationship with other spaces

ELEMENT A 15

Site Facilities

INTENT

To ensure that site facilities provide easy access to dwellings, are visually attractive, blend in with the development and street character, and require minimal maintenance.

PERFORMANCE CRITERIA

The intent may be achieved where:

- P1** Garbage bin areas, mail boxes and external storage facilities are sited and designed for attractive visual appearance and function, and complement the architecture and environs.
- P2** Garbage bin areas are designed for efficient and convenient use.
- P3** Site facilities enable collection of recyclable materials.
- P4** Site facilities include parking for bicycles according to projected user needs.
- P5** Mail boxes are located for convenient access by residents and deliverers, in a location visible from some dwellings on the site.
- P6** Dwellings are provided with adequate storage areas and external clothes drying facilities.

ACCEPTABLE SOLUTIONS

The Acceptable Solutions illustrate ONE WAY of meeting the associated Performance Criteria.

(in partial satisfaction of P5)

- A5** Individual mail boxes* are located close to each ground-floor dwelling entry, or a mail box structure is located close to the major pedestrian entrance to the site.

** Australia Post mail delivery requirements apply.*

- A6.1** For attached dwellings, a space of 8m³ per dwelling is set aside exclusively for storage. This space may form part of a carport or garage.

AND

- A6.2** Open air, communal clothes drying facilities are easily accessible to all residents and visually screened from public streets and from communal streets and recreational areas.

ELEMENT A16

Site Works

INTENT

To ensure the site works for developments do not adversely impact on adjoining properties and are consistent with the design intent for the site.

PERFORMANCE CRITERIA

The intent may be achieved where:

- P1** Construction earthworks, particularly pad construction:
 - does not undermine, or result in earth spillage onto, adjoining properties;
 - does not redirect or concentrate stormwater flows onto adjoining properties;
 - makes allowances for utility services crossing or servicing the site;
 - makes allowances for future landscaping works to ensure satisfactory performance of the storm drainage system.
- P2** The site works are undertaken so that earth and other materials are not tracked onto the public road way during the construction of the earthworks or the dwelling.
- P3** The site works are undertaken in such a manner as to ensure that there is no detriment by way of erosion, earth slippage or other hazard to adjoining properties during construction or in the event of building construction delay.

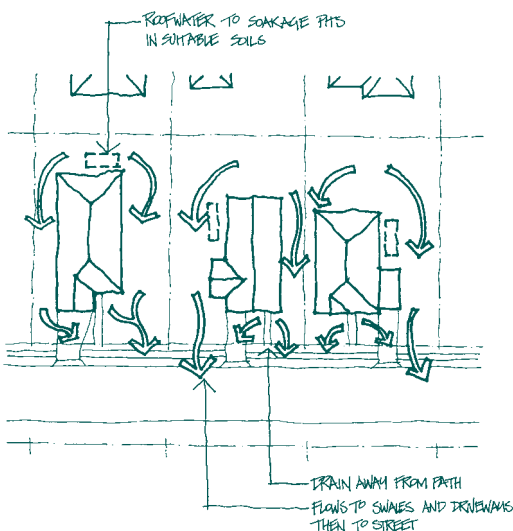

Figure 18: Site drainage methods

ACCEPTABLE SOLUTIONS

The Acceptable Solutions illustrate ONE WAY of meeting the associated Performance Criteria.

(in partial satisfaction of P1 to P3)

- A1** The submission of a Site Works Plan (or inclusion on the dwelling Site Plan) which demonstrates how the Performance Criteria are met showing:
 - details of all cut and fill showing finished levels, proposed methods of retaining cut and fill material;
 - site drainage paths after earthworks and allowance for landscaping; and
 - location of all services and their levels in relation to finished earthworks levels.

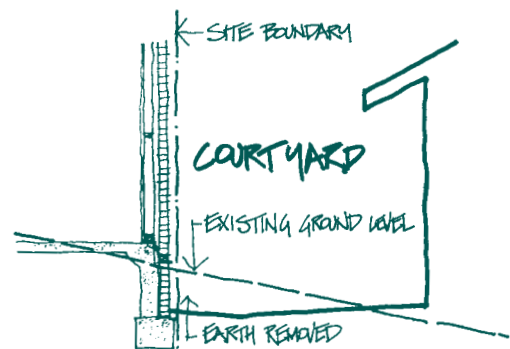

Figure 19: Desirable built to boundary detail
Low side of lot

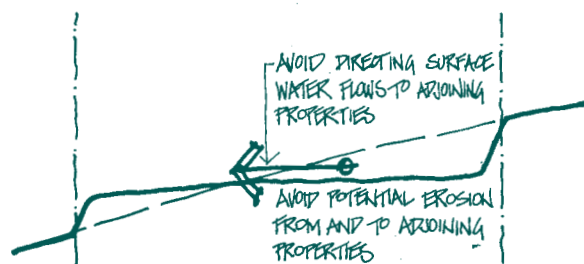

Figure 20: Earthworks site section

ELEMENT A16

Site Works *continued*

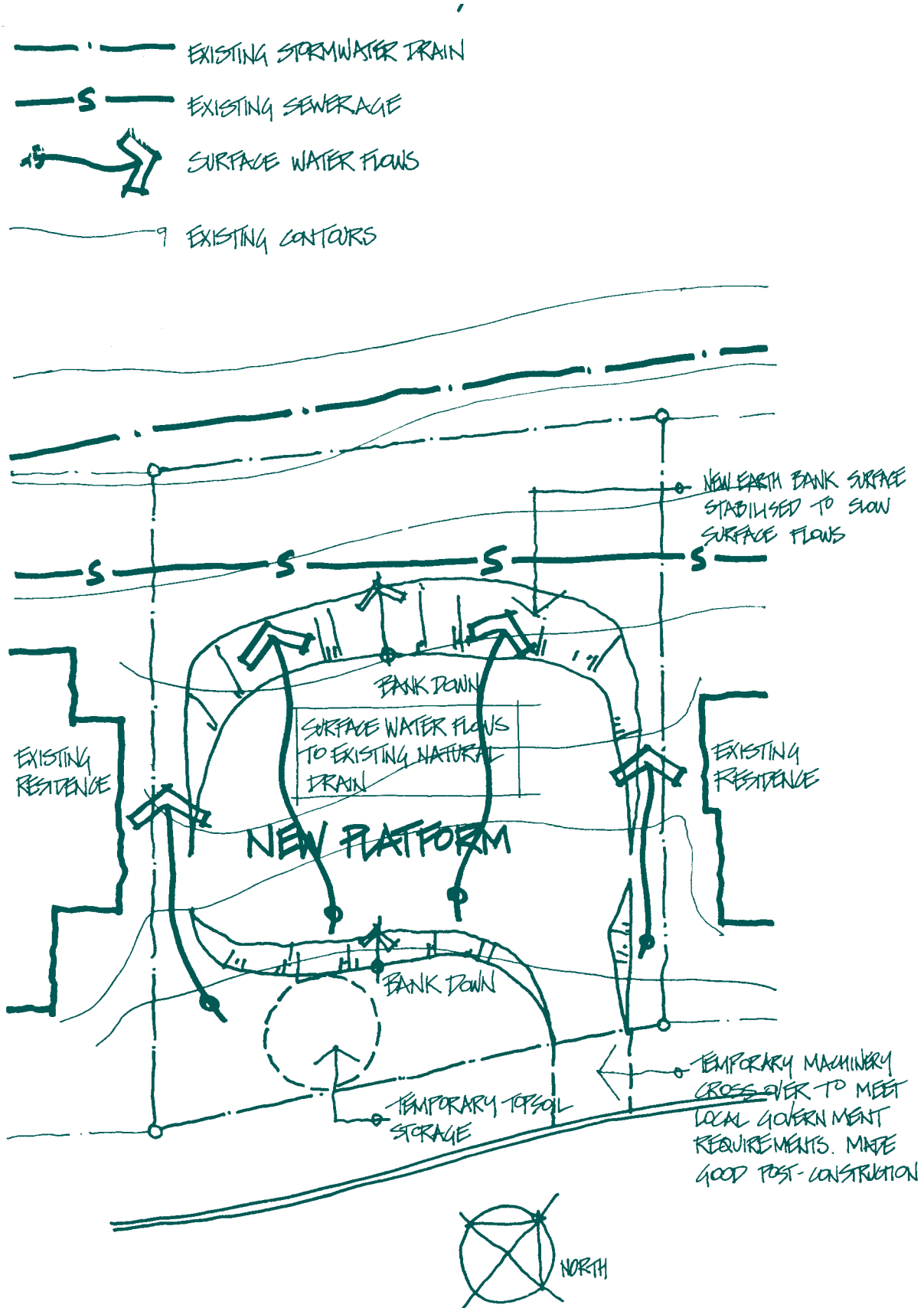

Figure 21: Typical site works plan

ELEMENT B1

Streetscape and Landscape

INTENT

To provide attractive streetscapes that reinforce the functions of a street, enhance the amenity of buildings, and are sensitive to the built form, landscape and environmental conditions of the locality.

PERFORMANCE CRITERIA

The intent may be achieved where:

- P1** The street, building and landscape design achieves:
- the creation of attractive residential environments with clear character and identity;
 - respect for existing attractive streetscapes in established areas;
 - appropriate streetscapes in areas where desired future urban character has been defined;
 - the infiltration of stormwater run-off wherever practicable (subject to climatic, soils and urban character criteria);
 - provision for appropriate street tree planting taking into account the image and role of the street, solar access requirements, soils, selection of appropriate species, and services;
 - use of such features of the site as views, vistas, existing vegetation and landmarks.
- P2** The design of the landscape in public and communal streets:
- defines a theme for new streets, or complements existing streetscapes and integrates with new development;
 - is sensitive to site attributes;
 - complements the functions of the street;
 - reinforces desired traffic speed and behaviour;
 - is of an appropriate scale relative to both the street reserve width and the building bulk;
 - promotes safety and casual street surveillance;

ACCEPTABLE SOLUTIONS

The Acceptable Solutions illustrate ONE WAY of meeting the associated Performance Criteria.

(in relation to P1 and P2)

- A1.1** A Streetscape Concept Plan* is submitted that demonstrates how the Performance Criteria are met, showing:
- the street reserve and indicative locations of the carriageway, parking bays, footpaths, cycleway systems, speed control devices and, where practicable, driveways, bus stops, street lighting and substations;
 - location of existing vegetation to be removed or conserved;
 - location, species and general character of tree planting, and hard and soft landscape treatment;
 - location and indicative treatment of building form (eg setbacks, front elevation, garage/carport location and design, and front garden treatments) and street furniture.

AND

- A1.2** For infill housing that abuts an existing public street, information should be submitted that demonstrates how the development fits in with an existing attractive streetscape or any statement of future urban character for that area.

* This plan may form part of or include a landscape plan. The need to complete such a plan will depend on local implementation requirements.

ELEMENT B1

Streetscape and Landscape continued

PERFORMANCE CRITERIA

- improves privacy and minimises unwanted overlooking;
- incorporates existing vegetation, where possible;
- appropriately accounts for streetscapes and landscapes of heritage significance;
- assists in microclimate management;
- maximises absorptive landscaped areas for on-site infiltration of stormwater where appropriate;
- integrates and forms linkages with parks, reserves and transport corridors;
- enhances opportunities for pedestrian comfort;
- achieves lines of sight for pedestrians, cyclists and vehicles;
- provides adequate lighting for pedestrian and vehicle safety;
- provides attractive and coordinated street furniture and facilities to meet user needs;
- satisfies maintenance and utility requirements and minimises the visual impact of above-ground utilities.

ACCEPTABLE SOLUTIONS

(in relation to P1 and P2)

- A1.3** Landscaping is in accordance with the approved landscape strategy for the area. Compliance with this requirement is achieved by submission of a plan meeting the Performance Criteria, and showing:
- boundaries and areas of communal open space including sites for specific recreational uses;
 - existing vegetation and proposed general character of landscape treatment;
 - general arrangement of hard landscaping elements and major earth cuts, fills and mounding; and
 - indicative treatment of floodways, drainage lines and the urban edge, along with general information on fencing, access points, furniture, pavement style, and treatment of the verge including any associated parking or drainage requirements.

ELEMENT B1

Streetscape and Landscape *continued*

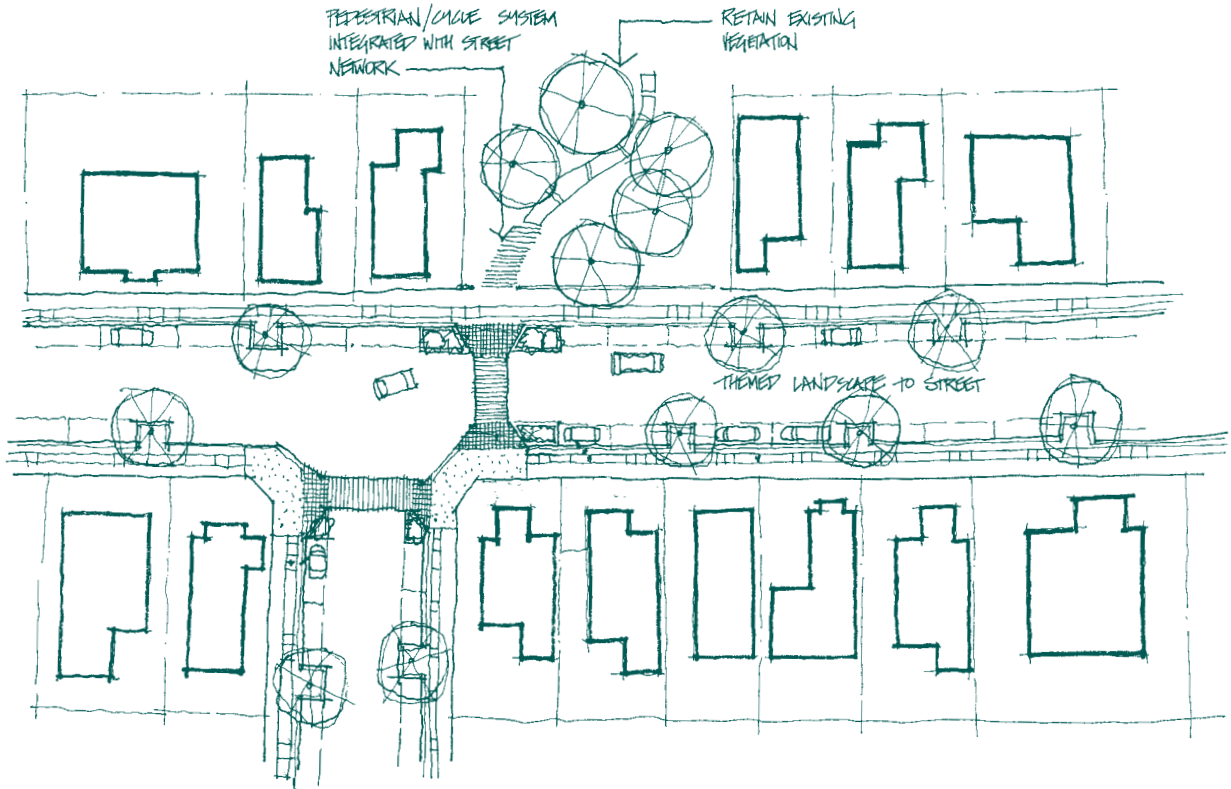

Figure 22: Streetscape concept plan

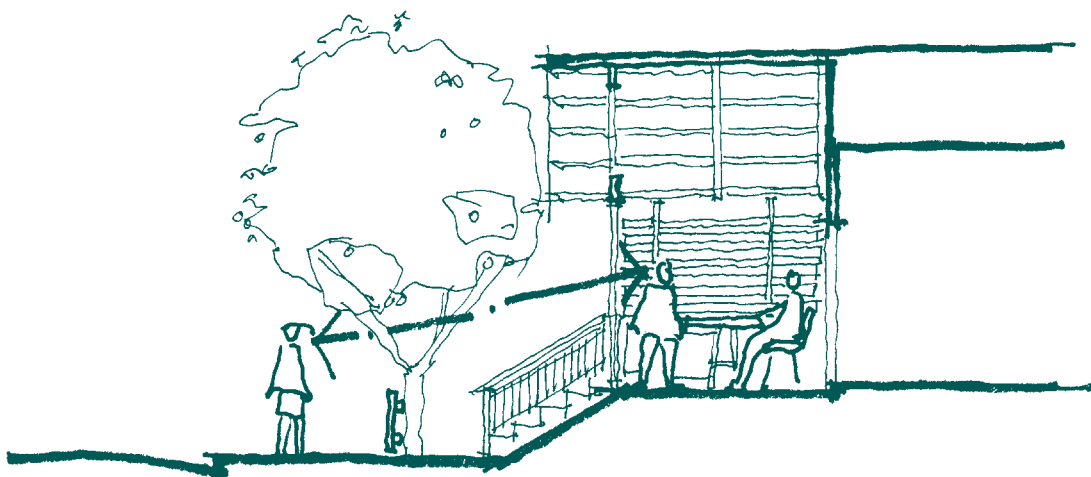

Figure 23: "Natural" surveillance to the street

ELEMENT B2

Building Appearance and Neighbourhood Character

INTENT

To ensure that building appearance from public streets and adjoining sites is attractive and visually compatible with either attractive surrounding development or the identified future urban character of the area.

PERFORMANCE CRITERIA

The intent may be achieved where:

- P1** The frontage of buildings and their entries are readily apparent from the street.
- P2** Building height at the street frontage maintains a compatible scale with adjacent development.
- P3** Buildings are designed to reflect relevant features of the prevailing character of surrounding streetscapes, features and built form character that have been identified as part of the desired future character of the area.
- P4** Buildings are designed to enhance the identified desirable existing built form character by translating the following characteristics found in the surrounding built form into innovative design solutions:
- mass and proportion;
 - building materials, patterns, textures, colours, and decorative elements;

ACCEPTABLE SOLUTIONS

The Acceptable Solutions illustrate ONE WAY of meeting the associated Performance Criteria:

(in relation to P1 to P4)

- A1.1** A Streetscape Concept Plan and/or Landscape Plan is submitted that demonstrates how the Performance Criteria are met.

OR

- A1.2** Buildings adjacent to the public street address the street by having a front door and/or living room or kitchen windows facing the street.

AND

- A2** Differences in building height between existing buildings and new development are not more than one storey when viewed from the public street and adjoining properties. This requirement applies to the building for a depth of one room.

(in partial satisfaction of P3 and P4)

- A3.1** Building design, roof form, detailing and materials visible from public areas and adjoining properties are not in strong visual contrast with the character of attractive neighbouring buildings.

AND

- A3.2** Building design enables individual dwellings to be identified from public streets.



Figure 24: Building appearance and neighbourhood character

ELEMENT B2

Building Appearance and Neighbourhood Character continued

PERFORMANCE CRITERIA

- ground-floor height above natural ground level;
 - floor to ceiling height;
 - roof form and pitch;
 - facade articulation, detailing, and window and door proportions;
 - verandahs, eaves and parapets;
 - driveway crossovers, fence style and alignment.
- P5** New development complements or enhances any treed landscape character of the area by:
- providing sufficient open space for the planting of trees to complement the landscape character of the neighbourhood;
 - retaining and protecting existing vegetation where possible;
 - protecting neighbouring trees from damage to their root systems;
 - using building footing designs, where necessary, that allow root growth of large trees.
- P6** The building design, detailing and finish provide an appropriate scale to the street, add visual interest and enable differentiation between dwellings when viewed from public streets.
- P7** Buildings are designed and sited to acknowledge the private open space of surrounding development, by:
- keeping upper storey parts of buildings away from neighbouring private open space so as to avoid an unreasonable sense of visual enclosure; and
 - using articulation, colour and detailing to reduce visual bulk.

ACCEPTABLE SOLUTIONS

ELEMENT B2

Building Appearance and Neighbourhood Character continued

PERFORMANCE CRITERIA

- P8** Garages and parking structures are sited and designed so as not to dominate the street frontage, by:
- minimising the frontage width;
 - minimising obtrusive projections of the structures beyond the main face of the building;
 - ensuring that roof form, materials and detailing complement that of the associated dwelling.
- P9** The location of carports and garages does not diminish the attractiveness of the streetscape, does not demote the views of the dwelling from the street and integrates with features of associated dwellings.
- P10** Existing dwellings in sound condition that contribute to the streetscape character and items of heritage or conservation significance are retained, incorporated and sympathetically treated, where possible.

ACCEPTABLE SOLUTIONS

(in partial satisfaction of P8)

- A8.1** Carports and garages are designed to be compatible with the dwelling design and with a maximum internal width of garage or carport of 6m or 50% of the frontage width, whichever is the less, where they face the street.
- A10** Items of heritage or conservation significance retained and sympathetically treated.

ELEMENT B3

Fences and Walls

INTENT

To ensure that front fences and walls, where used, improve amenity for residents and contribute positively to the streetscape and adjacent buildings.

PERFORMANCE CRITERIA

The intent may be achieved where:

- P1** Subject to P2, front fences and walls enable some outlook from buildings to the street to achieve safety and surveillance.
- P2** Where appropriate, front fences and walls enable use of private open space abutting the street and/or provide an acoustic barrier if traffic noise is excessive.
- P3** Front fences and walls assist in highlighting entrances;
- P4** The design and materials of front fences and walls are compatible with the associated development and with attractive fences and walls in the nearby visible locality.
- P5** Front fences and walls are compatible with facilities in the street frontage area, such as mail boxes and garbage collection areas.
- P6** The use and/or design of fences and walls in streetscapes of significance is appropriate to the heritage context.
- P7** Where overland water flows are probable, fences with strip footings provide for the movement of surface stormwater.

ACCEPTABLE SOLUTIONS

The Acceptable Solutions illustrate ONE WAY of meeting the associated Performance Criteria.

(in relation to P1 to P7)

- A1.1** A Streetscape Concept Plan and/or Landscape Plan is submitted that demonstrates how the Performance Criteria are met.

OR

(in relation to P1 and P2)

- A1.2** Front fences and walls are no more than 1.2m high if solid (forward of the building line). This height may be increased to 1.8m if the fence has openings which make it not less than 50% transparent;

OR

- A2** Solid front fences and walls to 1.8m high are limited to where:

- the main private open space is in front of the dwelling,

OR

- traffic volumes exceeds 6000vpd;

OR

- climatic considerations would provide a benefit to the dwelling or outdoor space.

PROVIDED THAT:

- the width is limited to a maximum of 75% of the frontage where private open space fronts the street;
- some surveillance of the street is maintained from the dwelling;
- fences do not exceed 10m in length without some articulation or detailing to provide visual interest.

ELEMENT B3

Fences and Walls *continued*

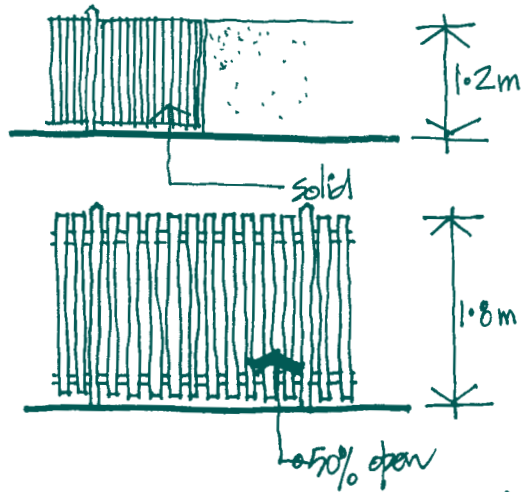

Figure 25: Typical front fences / walls

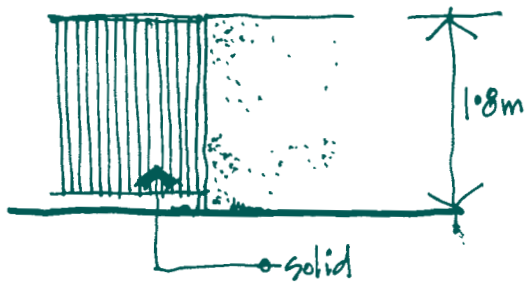

Figure 26: Fences for special privacy or noise control



Figure 27: Fence / wall articulation

ELEMENT B4

Bushfire Protection

INTENT

To reduce the level of fire risk associated with building in bushfire-prone areas by adopting suitable passive and active protection measures relating to siting, layout, design and construction techniques, and landscaping.

PERFORMANCE CRITERIA

The intent may be achieved where:

- P1** Building design and materials are selected to maximise resistance to fire.
- P2** In moderate and high-risk bushfire areas, an external sprinkler system is fitted to protect the walls and roof of a dwelling.
- P3** Each dwelling site is provided with a safe and secure water supply for fire fighting and protection.
- P4** Landscaping is designed to provide protection to buildings and not increase the level of bushfire risk.
- P5** The site layout of buildings, paths and landscaping creates a building protection zone and allows for ease of access to and from dwellings and other buildings.
- P6** The land division is designed to provide for a fuel-modified buffer area and the creation of building sites that minimise the risk of fire.
- P7** The road layout, design and construction take account of the needs of emergency vehicles and possible evacuation.

ACCEPTABLE SOLUTIONS

The Acceptable Solutions illustrate ONE WAY of meeting the associated Performance Criteria.

- A1** Buildings comply with the Building Code of Australia requirements for construction in bushfire-prone areas, and with relevant State or local authority regulations.

ELEMENT B5

Housing on Traffic Routes

INTENT

To ensure that housing located next to major roads is designed and constructed in a manner that reduces the adverse impact of traffic and leads to attractive streetscapes, functional roads and comfortable living conditions.

PERFORMANCE CRITERIA

The intent may be achieved where:

- P1** Dwellings are sited in a manner which:
- minimises the infiltration of noise into the buildings and the lot;
 - provides an acoustic barrier for private and communal open space;
 - reduces reflection of noise on to other buildings;
 - precludes the need to reverse on to a major road (for new lots and where the nature of an existing lot makes this possible).
- P2** Front fences and walls are designed to:
- supplement the noise control of the building facade;
 - enable some outlook to the street;
 - highlight entrances;
 - provide continuity and visual interest to the streetscape.
- P3** Higher side boundary fences and walls are designed or treated to reduce the angle of view to the noise source and minimise reflection on to the facade.
- P4** The room layout within the dwelling is arranged to reduce the impact of noise on the rooms which are most sensitive to noise (eg living rooms, bedrooms and recreation rooms).
- P5** Balconies and other external building elements are located, designed and treated to minimise infiltration and reflection of noise onto the facade.
- P6** The building plan, walls, windows, doors and roof are designed and detailed to reduce intrusive noise levels.

ACCEPTABLE SOLUTIONS

The Acceptable Solutions illustrate ONE WAY of meeting the associated Performance Criteria.

(in partial satisfaction of P1 to P8)

- A1** Buildings are constructed in accordance with Australian Standard 3671: Acoustics – Road Traffic Noise Intrusion, Building Siting and Construction, and Australian Standard 2107: Acoustics – Recommended Design Sound Levels and Reverberation Times for Building Interiors.

ELEMENT B5

Housing on Traffic Routes continued

PERFORMANCE CRITERIA

- P7** The integrity of the wall as a barrier to noise is maintained while providing adequate cross-flow ventilation and allowing natural light to penetrate the building.
- P8** The design and appearance of the facade of the building facing the traffic route achieve human scale and proportion, and reflect and reinforce the desired residential character of the area.
- P9** Landscaping is designed which:
- provides a sense of separation between the road and the private living environment;
 - is durable and suited to the conditions of the road environment.

ACCEPTABLE SOLUTIONS

ELEMENT B5

Housing on Traffic Routes *continued*

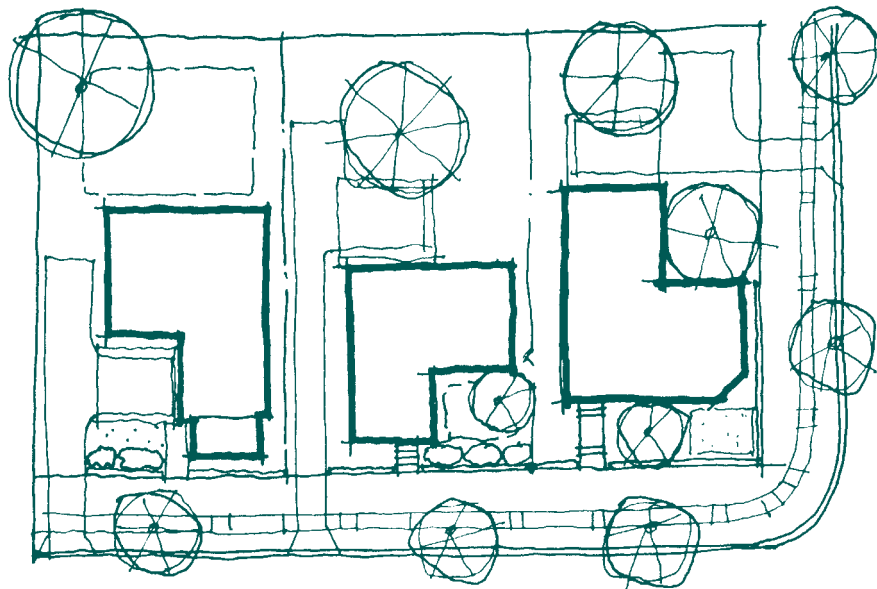

TREES AND PLANTINGS ON THE STREET MAKE A VISUAL BARRIER AND CAN SOFTEN A HARSH STREET ENVIRONMENT.

HOUSING, WALL AND FENCING DESIGNED FOR NOISE CONTROL CAN BE ARTICULATED AND VARIED.

NOISE CONTROL SHOULD NOT DETRACT FROM THE STREET CHARACTER AND SENSE OF IDENTITY
(NOTE: THIS ELEVATION SHOWS HOUSE FORMS BEHIND FENCES, WALLS AND LANDSCAPE)



TREES AND PLANTING ON THE STREET CREATE A VISUAL BARRIER AND SOFTEN THE STREET ENVIRONMENT

NOISE BARRIER WALLS AND FENCES CAN BE ARTICULATED AND VARIED TO ADD TO THE STREET SCAPE

ARTICULATION AND IDENTITY AT THE STREET FACADE
(NOTE: THIS ELEVATION SHOWS FENCES, WALLS AND LANDSCAPE ONLY)

Figure 28: Housing on traffic routes

DEFINITIONS

Acceptable Solution means an example of what may satisfy the relevant Performance Criteria (they should not preclude other solutions).

Access place means a minor cul-de-sac street providing local residential access, with shared traffic, pedestrian and recreation use.

Access street means a street providing local residential access with shared traffic, pedestrian and recreation use with local traffic access priority.

AMCORD means the Australian Model Code for Residential Development – A national resource document for residential development – November 1995.

AS means Australian Standard.

Balcony means any balustraded platform, 0.3 metres or more above adjacent finished ground level, either cantilevered or supported over open space, with access from the building via a door or window and with a minimum width of 1 metre.

BCA means Building Code of Australia.

Building envelope means a diagram drawn on a lot of a subdivision plan to the requirements of the Responsible Authority defining the limits for the siting and/or wall height of any dwellings and/or outbuildings, private open space, driveways and/or garages/carports.

Building height means the distance between natural surface level of the ground and the apex of a building's roof, but not including any receiving antennae, chimneys or flues.

Carriageway means the area of street or road reserve which is provided for the movement or parking of vehicles.

Casual surveillance refers to the ability to informally observe an area to enhance the level of security.

Collector Street – A street providing for local residential access and local traffic movement within performance limits defined in Queensland Streets.

Communal open space means usable community open space for recreation and relaxation of residents of a housing development and which is under the control of a body corporate or equivalent.

Communal street means the carriageway providing access to a housing development and which is under the control of a body corporate or equivalent.

Community Title refers to title given under the provisions of the Body Corporate and Community Management Act 1997 (BCCM Act) (formerly known as 'group title' under the Building Units and Group Titles Act 1980, which has been replaced by the BCCM Act).

Crossover refers to the paved accessway between the carriageway of a street and a development site.

Detached dwelling means a separate house on an individual lot (including a community title lot).

Development Area means an area identified as having potential for housing following strategic planning and study.

Duplex means a building comprising two attached dwellings on the same lot.

Established area means an existing neighbourhood where the vast majority of land is developed.

Flat or apartment (including attached to a shop, office etc) includes one or more of the following:

- units constructed over the top of each other;
- shared communal open space in lieu of or as well as private open space;
- shared parking/access arrangements;
- attached to a detached dwelling (with shared access/site facilities).

Frontage means the street alignment at the front of a lot and in the case of a lot that abuts two or more streets, the boundary of which, when chosen, would enable the lot to comply with these provisions.

Habitable room means a room used for normal domestic activities that includes:

- a bedroom, living room, lounge room, music room, television room, kitchen, dining room, sewing room, study, playroom and sunroom,

but excludes:

- a bathroom, laundry, water closet, food storage pantry, walk-in wardrobe, corridor, hallway, lobby, photographic darkroom, clothes drying room, and other spaces of a specialised nature occupied neither frequently nor for extended periods.

Height of a wall at any point for the purpose of determining its setback from a boundary means the vertical distance between the top of the eaves at the wall line, parapet or flat roof (not including a chimney), whichever is the highest, and the natural ground level of the lot boundary at a point at right-angles to the wall. Where a skillion roof occurs, the height shall be measured as the median height of the wall. When a triangular gable roof occurs, the heights shall be measured as the height of the wall together with one-third of the vertical height of the gable.

DEFINITIONS continued

Infill housing is a general term used for new housing in existing residential areas and usually involving the use of a vacant site or the removal of an existing dwelling to enable construction of a larger number of dwellings.

Intent (or Element Intent) means a statement of the desired outcomes to be achieved in the completed development, relating to particular Design Elements.

Landscape plan means a plan or document outlining the extent, type and location of proposed landscaping and planting.

Lot means an area of topographical space shown on an approved plan of subdivision and on which it is intended to construct a dwelling or dwellings.

Multi-unit dwellings means the development of more than one dwelling on a site where facilities are shared (eg access, parking, communal open space/facilities).

Nature strip refer to verge.

Outermost projection means the outermost projection of any structural part of a building or other structure including, in the case of a roof, the outside face of the fascia, or the roof structure where there is no fascia, but does not include any rainwater fittings, ornamental or architectural attachment.

Performance Criteria means criteria to be used in the preparation, submission and assessment of development proposals for measuring performance of the proposals against the Element Intent.

Plan of Development means a plan approved as part of a planning process which identifies the precise conditions for housing and other activities.

Private open space means an open area of land or building attached to a dwelling (eg balcony or roof garden) intended for the exclusive use of the occupants of the dwelling, and located and designed so as to offer visual privacy to the occupants.

Public open space means land used or intended for use for recreational purposes by the public and includes parks, public gardens, riverside reserves, pedestrian and cyclist accessways, playgrounds and sports grounds.

Setback means the shortest distance measured horizontally from the outermost projection of the building or other structure concerned to the vertical projection of the boundary of the allotment.

Site analysis involves the identification and analysis of the existing urban character and adjacent properties to assist in understanding the locality and the development of a range of appropriate design responses.

Site Analysis Plan means a plan which demonstrates an appreciation of a site and its context to identify opportunities and constraints on site layout and design. The plan may include information on topography and services, existing buildings on site, vegetation on site, adjoining property conditions, views, noise sources and street character and context.

Site density means the ratio of dwellings to the area of the site they occupy (including communal streets and communal open space).

Site means the lot(s) of land on which a building stands or is to be erected.

Storey means a space within a building which is situated between one floor level and the floor level next above, or if there is no floor above, the ceiling or roof above. It does not include a room contained wholly within the roof space or a parking area contained wholly within a basement which is below the natural ground level.

Street – Any street, lane, square, court, alley and other carriageways whose primary purpose is providing access to residential buildings.

Street pavement see Carriageway.

Street reserve means the land set aside for a street pavement and verge.

Streetscape plan means the portion of the development plan showing the visible components within a street (or part of a street) between facing buildings, including the form of buildings, setbacks, fencing, landscaping, driveway and street surfaces, utility services and street furniture such as lighting, signs, barriers and bus shelters.

Subdivision means the division of a parcel of land into two or more parts for the purpose of enabling any of the lots to be disposed of separately.

Verge means that part of the street or road reserve between the carriageway and the boundary of adjacent lots (or other limit to street reserve). It may accommodate public utilities, footpaths, stormwater flows, street lighting poles and planting.

Wall height refer to Height of Wall.

Weighting means a process of determining priorities for various Design Elements and Performance Criteria in the consideration of designing and assessing development proposals.

Window includes a roof skylight, glass panel, glass brick, glass louvre, glazed sash, glazed door, translucent sheeting or other device which transmits natural light directly from outside a building to the room concerned.

REFERENCES

Australian Road Research Board (ARRB) (1989): Structural design guide for residential street pavements, Special Report No. 41 prepared by P.J. Mulholland.

Department of Primary Industries-Water Resources (DPI), Institute of Municipal Engineering Australia, Qld. Division, Brisbane City Council (November 1994): Queensland urban drainage manual, (QUDM) prepared by Neville Jones and Associates Pty Ltd and Australian Water Engineering.

Institute of Municipal Engineering Australia, Qld Division (IMEAQ) (1993, incorporating 1996 update): Queensland streets-design guidelines for subdivisional streetworks, prepared by Weathered Howe Pty Ltd.

Whelans and Halpern Glick Maunsell (1994): Planning and management guidelines for water-sensitive urban (residential) design, Report prepared for Dept Planning and Urban Development, Water Authority of WA and EPA, Perth.

APPENDIX

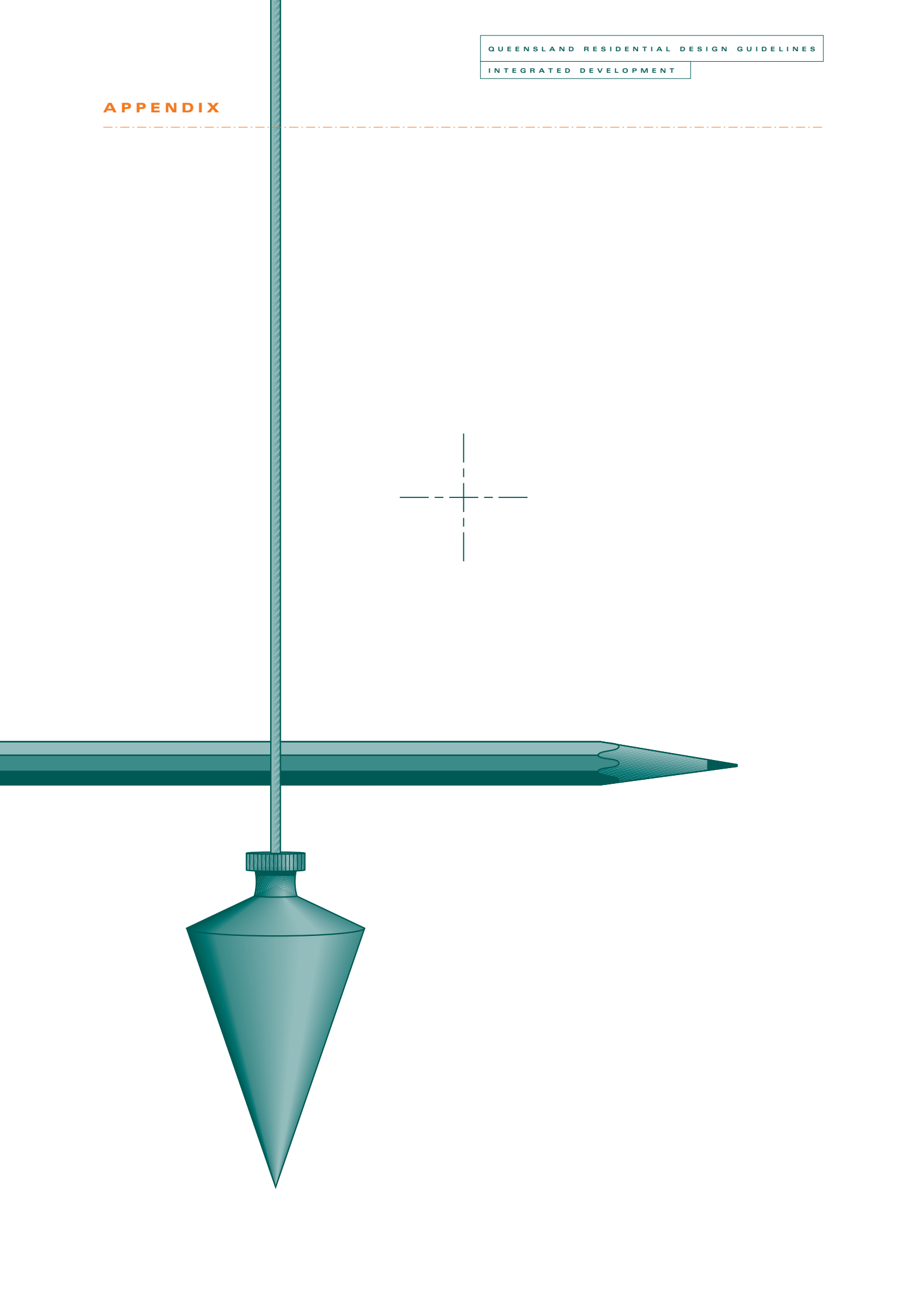

ELEMENT C1

Safety and Security

INTENT

To provide personal and property security for residents and visitors and enhance perceptions of community safety.

PERFORMANCE CRITERIA

The intent may be achieved where:

- P1** Buildings are designed to overlook public and communal streets and other public areas to provide casual surveillance.
- P2** Site planning, buildings, fences, landscaping and other features clearly define territory and ownership of all public, common, semi-private and private space.
- P3** Appropriate lighting is provided to all pedestrian paths between public and shared areas, parking areas and building entries, and building entries provide a sense of security for both residents and visitors.
- P4** Large development sites are 'subdivided' into specific territorial zones which are 'assigned' to groups of dwellings.
- P5** Buildings are designed to minimise access between roofs, balconies and windows of adjoining dwellings.
- P6** Vulnerable materials are avoided and robust materials which are aesthetically pleasing are used in public or communal spaces.
- P7** Pedestrian site access and carparking are clearly defined, appropriately lit, visible to others and provide direct access to buildings from areas likely to be used at night.
- P8** Major pedestrian, cycle and vehicle thoroughfares are identified and reinforced as 'safe routes' through:
- appropriate lighting;
 - the potential for casual surveillance from houses;
 - minimised opportunities for concealment;
 - landscaping which allows long-distance sight lines;
 - avoidance of 'blind' corners.

SUGGESTED SOLUTIONS

The Suggested Solutions illustrate ONE WAY of meeting the associated Performance Criteria.

- A1** Buildings adjacent to public or communal streets or open space have at least one habitable room window with an outlook to that area.

(in partial satisfaction of P3 and P4)

- A3.1** Building design allows visitors who approach the front door to be seen without the need to open the door.

AND

- A3.2** Shared entries serve a maximum of eight dwellings and are able to be locked.

ELEMENT C1

Safety and Security continued

PERFORMANCE CRITERIA

- P9** Individual dwellings are clearly identifiable by visitors and emergency vehicles.
- P10** Public facilities, including public toilets and street furniture, are located to maximise opportunities for casual surveillance, and are designed and constructed of high-quality, robust materials.
- P11** A diversity of complementary land-use activities is provided to encourage a public presence at different times of the day and night.
- P12** Landscape and fencing do not present a security risk by screening doors, windows and major paths.

SUGGESTED SOLUTIONS

ELEMENT C2

Design for Climate

INTENT

To facilitate energy and water conservation measures in and around housing that will assist in establishing ecologically sustainable residential environments, through the reduction in household use of fossil fuels and greenhouse gas emissions and the use of renewable energy sources.

PERFORMANCE CRITERIA

The intent may be achieved where solar access is available and where:

In all climates

- P1** Building envelopes and internal layouts are designed to minimise energy consumed for heating and cooling.
- P2** Windows are located, sized and shaded to facilitate good thermal performance.
- P3** Dwellings have an area of roof, with appropriate orientation and pitch, that is suitable for the installation of solar collectors and photovoltaic cells.
- P4** Building materials and insulation assist in providing acceptable thermal conditions.
- P5** Air movement within dwellings is designed to provide acceptable thermal conditions.
- P6** Building materials, appliances and fuel sources are selected to minimise energy requirements and greenhouse gas emissions.
- P7** Landscape design assists microclimate management to conserve energy and water.
- P8** Building and landscape design incorporate techniques for conserving mains water.

SUGGESTED SOLUTIONS

The Suggested Solutions illustrate ONE WAY of achieving the Performance Criteria:

In all climates

(in relation to P1 to P5)

- A1** There is a minimum rating of four stars for any dwelling on its own separate lot, or four stars for 50% of dwellings and three stars for the remaining dwellings within a multi-unit housing development, under a nationally accredited House Energy Rating Scheme.

OR

(in partial satisfaction of P1 to P5)

- A2.1** Doors, windows and other openings have adequate draught control.
- AND
- A2.2** Mechanically heated or cooled areas can be closed off from other areas of the dwelling.
- AND
- A2.3** Buildings (other than in the hot-humid climate zone) are sited within the preferred orientation range shown in Figure 29.
- AND
- A2.4** A north-facing room is provided, capable of use as a living area.
- AND
- A2.5** Ceiling and wall insulation is provided to at least the level recommended in AS 2627.1-1993 for the locality.

AND

ELEMENT C2

Design for Climate continued

PERFORMANCE CRITERIA

In temperate climates

- P9** Dwellings are sited and designed to maximise solar access to north-facing windows of living areas and principal areas of open space, having regard to slope, views, existing vegetation and overshadowing.
- P10** Windows are appropriately sized and shaded to reduce summer heat load and permit entry of winter sun.

In cool-temperate climates

- P11** Dwellings are sited and designed to maximise solar access to north-facing windows of living areas and principal areas of open space, having regard to slope, views, existing vegetation and overshadowing.
- P12** Dwellings are designed for maximum solar access during cooler months.
- P13** Dwellings and landscaping are designed to ensure protection from winter winds.
- P14** Dwellings are mainly constructed of materials with high thermal mass.

SUGGESTED SOLUTIONS

In all climates (continued)

- A2.6** External clothes drying areas with access to sunlight and breezes are available.

In temperate climates

(in partial satisfaction of P9 and P10)

- A9.1** Windows to north-facing living areas receive at least 3 hours of sun between 9am and 5pm on 21 June over a portion of their surface.

AND

- A9.2** North-facing windows to living areas of neighbouring dwellings do not have sunlight reduced to less than the above 3 hours.

AND

- A9.3** Materials of high thermal mass are used for living areas and are located to maximise the absorption of heat from air circulating in the dwelling and from the winter sun.

In cool-temperate climates

(in partial satisfaction of P11 to P14)

- A11.1** Windows to north-facing living areas receive at least 3 hours of sun between 9am and 5pm on 21 June over a portion of their surface.

AND

- A11.2** North-facing windows to living areas of neighbouring dwellings do not have sunlight reduced to less than the above 3 hours.

AND

- A11.3** East-facing windows (with external shading to restrict summer sun) are provided for morning sunlight during cooler months.

ELEMENT C2

Design for Climate continued

PERFORMANCE CRITERIA

In hot-humid climates

- P15** Dwellings are sited to maximise the use of cooling breezes and provide natural ventilation.
- P16** Dwellings are designed to:
 - minimise the need for mechanical cooling;
 - maximise cross-ventilation;
 - use shade structures over all windows and external doors;
 - naturally ventilate roof spaces;
 - provide for covered outdoor living areas;
 - avoid long walls along western boundaries.
- P17** Fences are of semi-open construction for breeze penetration.
- P18** Trees and vegetation provide as much shade as possible both on-site and on-street.

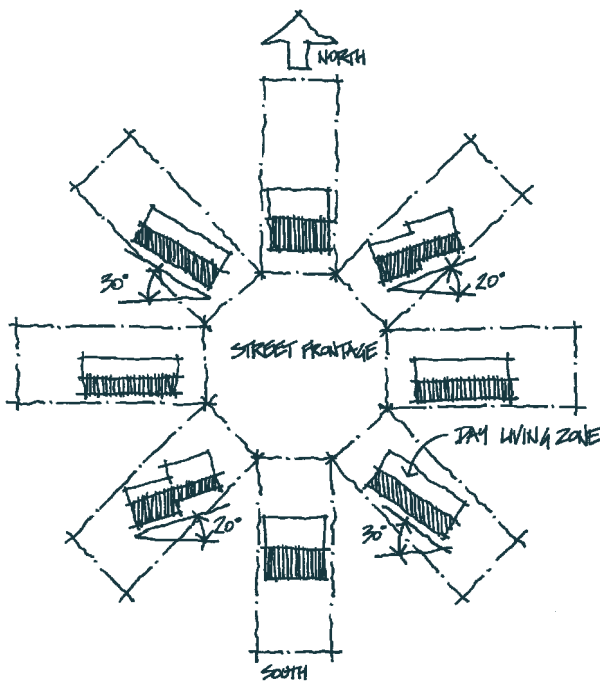

Figure 29: Suggested positioning of houses on sites with varied aspects to achieve low-energy housing in temperate climate zones

SUGGESTED SOLUTIONS

In hot-humid climates

(in partial satisfaction of P15 to P18)

- A15.1** Buildings are designed with openings on opposite or adjacent walls for cross-ventilation.
AND
- A15.2** All habitable rooms are naturally ventilated, with a minimum openable area of 5% of the floor area of that room.
AND
- A15.3** All external openings are protected from direct sunlight by permanently fixed shade devices.
AND
- A15.4** Roof spaces are ventilated with louvre openings (eg gable end) or by roof-mounted ventilators (subject to Cyclone Code).
AND
- A15.5** Verandahs and balconies are provided and are not less than 10m² with a minimum dimension of 2.5m, and are covered for a minimum of 30% of their area.
AND
- A15.6** Roofs are lightweight and light-coloured, and roofs and walls are insulated to at least the level recommended in AS 2627.1-1993.
AND
- A15.7** A vapour barrier membrane is installed on the outside of the bulk insulation. Perforated breather paper is installed in all other walls (to restrict condensation buildup).
AND
- A15.8** Lightweight materials are used in buildings in the most northern and hotter regions, particularly within bedrooms.

ELEMENT C2

Design for Climate continued

PERFORMANCE CRITERIA

In hot-arid climates

- P19** Dwellings incorporate courtyards with summer shade and vegetation.
- P20** Dwellings are designed to provide midday shade all year round but with some early morning solar penetration.
- P21** Dwellings are sited to maximise the use of cooling breezes.
- P22** Dwellings are designed to:
- minimise the need for mechanical cooling;
 - maximise cross-ventilation;
 - use shade structures over all windows and external doors;
 - naturally ventilate roof spaces;
 - provide for covered outdoor living areas;
 - avoid long walls along western boundaries.
- P23** Trees and vegetation provide as much shade as possible both on-site and on-street.

SUGGESTED SOLUTIONS

In hot-arid climates

(in partial satisfaction of P19 to P23)

- A19.1** Buildings and landscaping are sited and designed to provide shade to walls and the roof all year round.
- AND
- A19.2** Courtyards are provided with summer shade and vegetation.
- AND
- A19.3** Walls to living areas are constructed using materials of high thermal mass and walls to bedrooms are constructed using materials of low thermal mass.
- AND
- A19.4** Buildings are sited to maximise available cool breezes.
- AND
- A19.5** Buildings are designed with openings on opposite or adjacent walls for cross-ventilation.
- AND
- A19.6** All habitable rooms are naturally ventilated, with a minimum openable area of 5% of the floor area of that room.
- AND
- A19.7** All external openings are protected from direct sunlight by shade devices.
- AND
- A19.8** Roof spaces are ventilated with louvre openings (eg gable end) or by roof-mounted ventilators and are bulk insulated.

ELEMENT C2

Design for Climate *continued*

PERFORMANCE CRITERIA

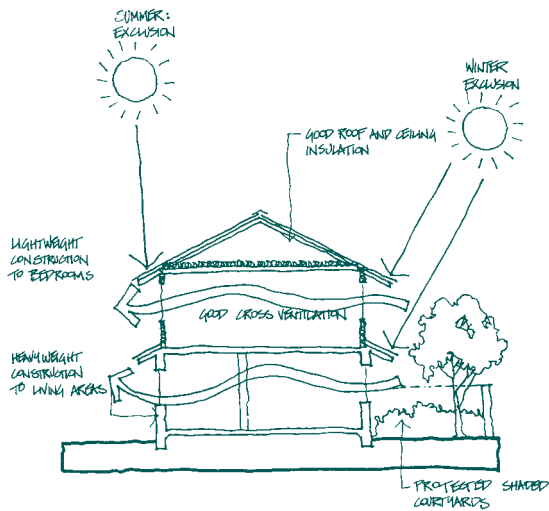

Figure 30: Design for climate
Hot-arid climate

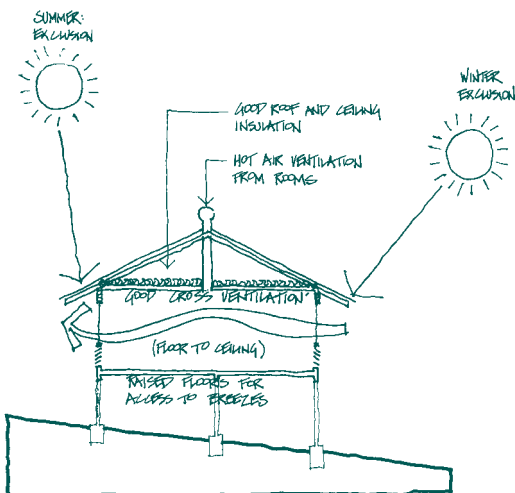

Figure 31: Design for climate
Hot-humid climate

SUGGESTED SOLUTIONS

In hot-arid climates (continued)

AND

A19.9 Verandahs and balconies are provided and are not less than 10m² with a minimum dimension of 2.5m, and are covered for a minimum of 30% of their area.

AND

A19.10 Roofs are lightweight and light-coloured, and roofs and walls are insulated to at least the level recommended in AS 2627.1-1993.

AND

A19.11 A vapour barrier membrane is installed on the inside of the bulk insulation in order to restrict condensation buildup.

AND

A19.12 The house is designed with a longer east-west axis.

AND

A19.13 Windows are located on the north and south walls only.

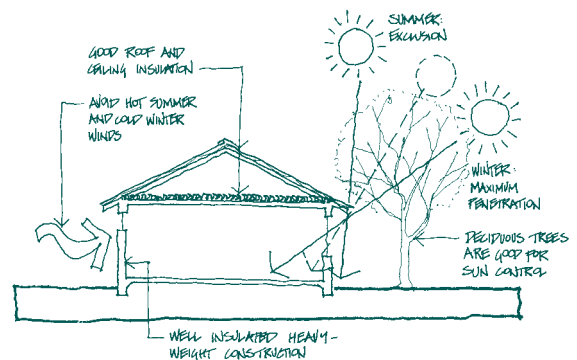

Figure 32: Design for climate
Cool-temperate / temperate climate

ELEMENT C3

Privacy

INTENT

To site and design buildings to meet projected user requirements for visual and acoustic privacy, and to protect the visual and acoustic privacy of nearby residents in their dwellings and private open space.

PERFORMANCE CRITERIA

The intent may be achieved where:

- P1** The privacy of buildings and outdoor spaces is protected taking into account projected community expectations.

Visual privacy

- P2** Direct overlooking of main internal living areas and private open spaces of other dwellings is minimised by building layout, location and design of windows and balconies, screening devices and landscape, or remoteness. Effective location of windows and balconies to avoid overlooking is preferred to the use of screening devices, high sills or obscured glass. Where these are used, they should be integrated with the building design and have minimal negative effect on residents' or neighbours' amenity.

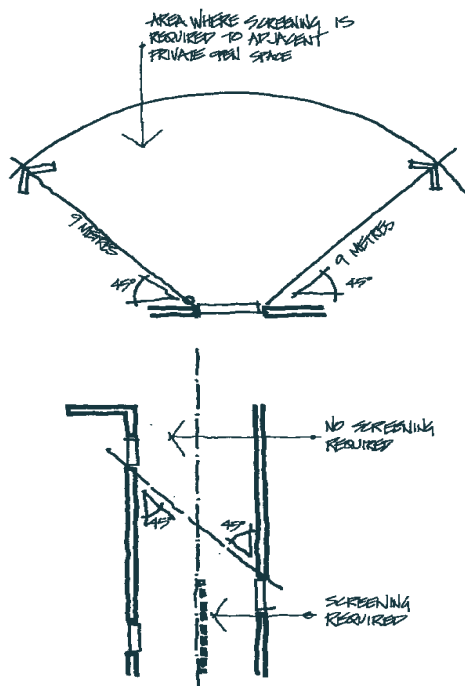

Figure 33: Privacy
Outlook from windows

SUGGESTED SOLUTIONS

The Suggested Solutions illustrate ONE WAY of meeting the associated Performance Criteria.

Visual privacy

- A2.1** Habitable room windows with a direct outlook to the habitable room windows in an adjacent dwelling within 9m:
- are offset from the edge of one window to the edge of the other by a distance sufficient to limit views into the adjacent windows;
 - have sill heights of 1.7m above floor level; or
 - have fixed obscure glazing in any part of the window below 1.7m above floor level.

AND

- A2.2** Outlook from windows, balconies, stairs, landings, terraces and decks or other private, communal or public areas within a development is obscured or screened where a direct view is available into the private open space of an existing dwelling.

If screening is used, the view of the area overlooked must be restricted within 9m and beyond a 45° angle from the plane of the wall containing the opening, measured from a height of 1.7m above floor level (see Figure 33).

No screening is required where:

- windows are in bathrooms, toilets, laundries, storage rooms or other non-habitable rooms and they have translucent glazing or sill heights of at least 1.7m;
- windows are in habitable rooms and they have sill heights of 1.7m or more above floor level or translucent glazing to any part of a window less than 1.7m above floor level.

ELEMENT C3

Privacy continued

PERFORMANCE CRITERIA

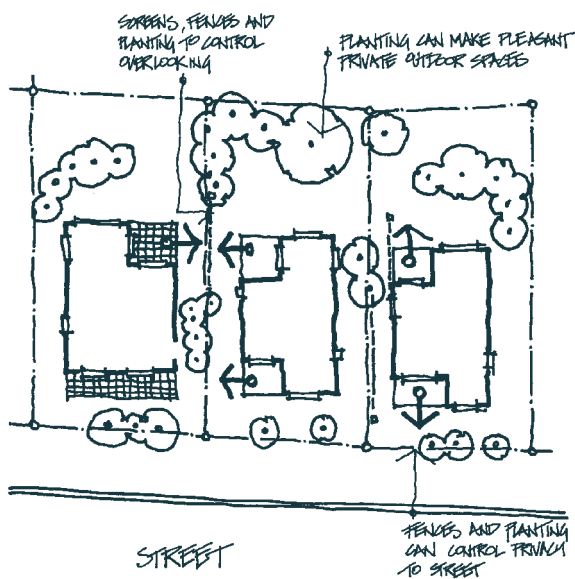

Figure 34: Privacy
Street / allotment

Acoustic privacy

- P3** Site layout separates, by way of barriers and/or by distance, active recreational areas, parking areas, vehicle accessways and service equipment areas from bedroom areas of dwellings, and minimises high levels of external noise entering dwellings.
- P4** Dwellings close to high-noise sources (eg busy roads, railway lines, airport flight-paths or industry) should be designed to locate noise-sensitive rooms and secluded private open spaces away from noise sources, and be protected by appropriate noise-shielding techniques.
- P5** Building design assists in minimising the transmission of sound through the building structure, and particularly protects sleeping and living areas from possible noise intrusion.

SUGGESTED SOLUTIONS

Visual privacy (continued)

AND

A2.3 Windows and balconies of an upper-level dwelling are designed to prevent overlooking of more than 50% of the private open space of a lower-level dwelling directly below and within the same development.

AND

A2.4 Direct views described in A2.2 and A2.3 may be obscured by solid translucent screens or perforated panels or trellises which have a maximum of 25% openings, and which are:

- permanent and fixed
- of durable materials
- designed and painted or coloured to blend in with the development.

Acoustic privacy

(in partial satisfaction of P3)

A3 Bedroom windows are at least 3m from shared streets and driveways and parking areas of other dwellings.

(in partial satisfaction of P5)

A5.1 Bedrooms of one dwelling do not share walls with living rooms or garages of adjacent dwellings.

AND

A5.2 Shared walls and floors between dwellings are constructed in accordance with the noise transmission and insulation requirements of the Building Code of Australia.

ELEMENT C4

Dwelling Unit Entry and Interior

INTENT

To provide dwelling entries that create a sense of individual identity and offer adequate personal security for residents, and provide internal dwelling layouts to suit projected user requirements.

PERFORMANCE CRITERIA

The intent may be achieved where:

- P1** Entries to dwellings:
- are clearly visible from streets or internal driveways so that visitors can easily identify a particular dwelling;
 - give the resident a sense of personal address, shelter and transitional space around the entry;
 - help provide a level of security for the occupants.
- P2** The dwelling layout ensures:
- general surveillance of the site and approaches to entries is possible from inside dwellings;
 - ground-floor dwellings are accessible to people with disabilities or can be easily modified to achieve this.
- P3** Dwellings are planned so that:
- noise transmission between them is minimised by not locating the noisy areas of one dwelling next to the quiet areas of another;
 - circulation areas are minimised, and floor plans ensure that circulation space facilitates functional use of rooms;
 - views and outlook are maximised, particularly from living rooms;
 - internal storage space is included;
 - direct or convenient access from a living area to private open space is provided.

SUGGESTED SOLUTIONS

The Suggested Solutions illustrate ONE WAY of meeting the associated Performance Criteria.

(in partial satisfaction of P1)

- A1.1** Entries to dwellings enable visitors to be seen from inside the dwelling without opening the door.

AND

- A1.2** Shared entries, such as semi-interior or interior stairways, corridors or balcony walkways, are limited to service a maximum of eight dwellings.

(in partial satisfaction of P3)

- A3** Garages are located away from bedrooms of adjacent dwellings.

ELEMENT C4

Dwelling Unit Entry and Interior continued

PERFORMANCE CRITERIA

- P4** Internal layout of dwellings designed for more than one person is adaptable to a range of household types, by maximising potential for personal space and privacy through:
- providing more than one larger bedroom (suitable to fit a double bed);
 - separating bedrooms from each other with bathrooms or other rooms, or locating them next to walls with minimum noise transmission;
 - providing more than one living space or a living-dining space that can be functionally divided;
 - arranging rooms off a central circulation space connected to the entry.
- P5** Detailing of dwellings ensures that:
- window design and location contribute to a sense of spaciousness and connection with the outdoors, while enabling control for ventilation and security;
 - room shapes and dimensions allow flexibility in use and furniture arrangement;
 - entries, doors and passageways are wide enough to allow for furniture movement and wheelchair access.

SUGGESTED SOLUTIONS

ELEMENT C5

Stormwater Harvesting

INTENT

To develop the resource potential of stormwater to supply a range of second-quality water uses presently met from town supply systems.

PERFORMANCE CRITERIA

The intent may be achieved where:

- P1** Direct stormwater use systems are effective in collecting, storing and applying appropriate physical treatment to storm run-off for immediate use.
- P2** Indirect stormwater use systems are effective in collecting, applying physical treatment to, storing and retrieving storm run-off for use as required.
- P3** Stormwater use systems provide the community with opportunities to reduce mains water use.
- P4** Stormwater use systems provide the community with water for second-quality uses, leading to cost reductions.
- P5** Stormwater use systems which incorporate constructed wetlands environments make positive contributions to urban amenity.
- P6** Stormwater use systems are effective in reducing the costs of downstream storm drainage.
- P7** Aquifers chosen for long-term storage of storm run-off can be effective components of comprehensive direct and indirect stormwater use schemes.

SUGGESTED SOLUTIONS

There are no Suggested Solutions for this Element, as each situation requires an individual approach.

QUEENSLAND RESIDENTIAL
DESIGN GUIDELINES

Subdivision

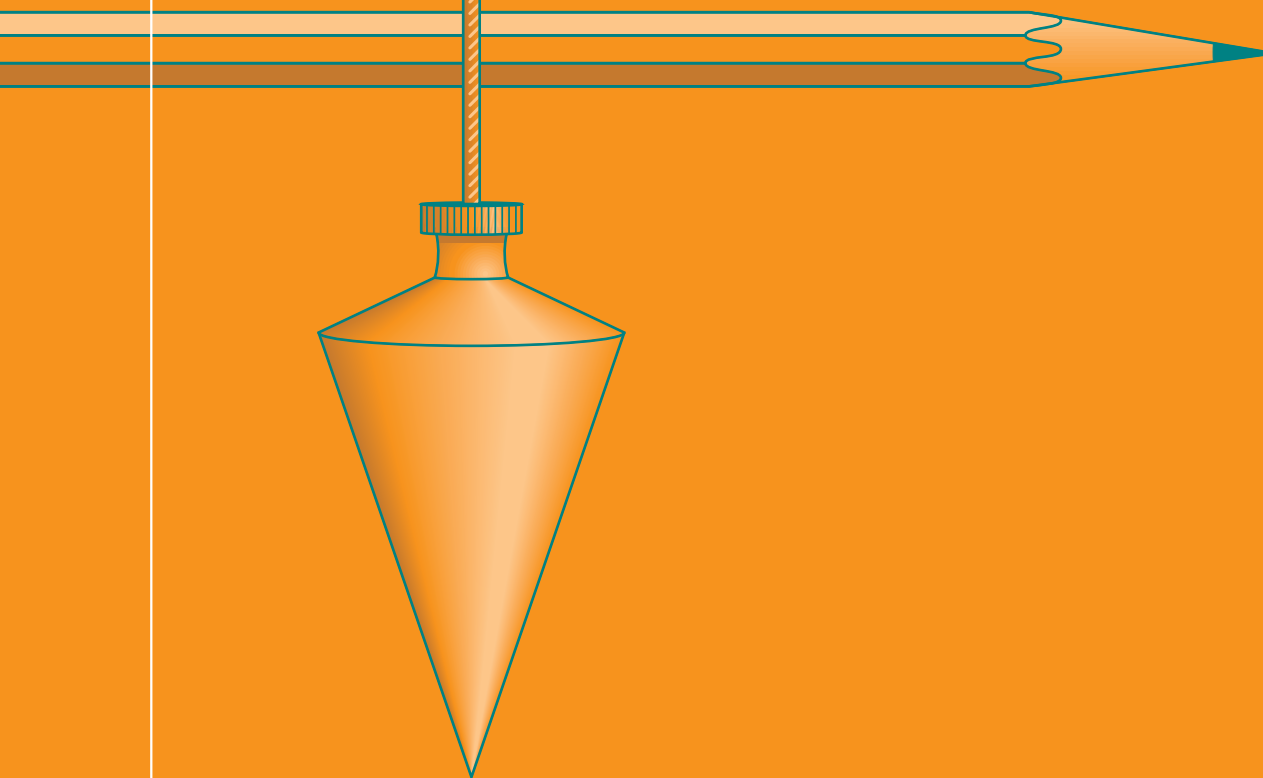

TABLE OF CONTENTS

Part 4 – Subdivision

1.0	INTRODUCTION	1
1.1	APPLICATION OF DESIGN GUIDELINES	2
1.2	THE PERFORMANCE APPROACH	3
1.3	SITE ANALYSIS	4
1.4	DESIGN ELEMENTS	
	A GENERAL	
	A1 Neighbourhood Design	7
	A2 Street Networks	10
	A3 Public Open Space	12
	A4 Street Design	14
	A5 Street Construction	18
	A6 Utilities	19
	A7 Storm Drainage	21
	A8 Water Quality Management	23
	A9 Lot Layout	24
	B SITE SPECIFIC	
	B1 Bushfire Protection	25
	DEFINITIONS	26
	REFERENCES	28
	APPENDIX	
	C ADVISORY DESIGN ELEMENTS	
	C1 Stormwater Harvesting	31

1.0 Introduction

The Queensland Residential Design Guidelines have been produced for use by planners, designers, local government development control officers, builders, and developers involved in housing and residential development in Queensland.

The Guidelines are derived from the provisions of the Australian Model Code for Residential Development – A National Resource Document (AMCORD 1995), with modifications to suit Queensland conditions.

The Guidelines have four sections:

- 1 Single Detached Housing – for planning, design, and development of detached houses.
- 2 Attached Housing – for planning, design, and development of all forms, types, and arrangements of attached housing up to 3 storeys in height, or 3 storeys over carparking.
- 3 Integrated Development – for integrated planning, design, and development of projects comprising 2 or more houses (includes residential components of mixed-use projects).
- 4 Subdivision – for planning, design and development of land subdivision for residential purposes, prior to housing construction.

Each section:

- comprises design elements presented using a performance-based approach (including intent, performance criteria, and a range of acceptable solutions suitable for Queensland).
- includes only those design elements of relevance to the particular type of residential development under consideration.
- references to related publications such as Queensland Streets and the Queensland Urban Drainage Manual.

Queensland Streets (IMEAQ 1996) provides the basis for a uniform standard of residential streetworks design, with detailed design criteria in accordance with AMCORD principles.

The Queensland Urban Drainage Manual (DPI et al, 1993) provides planning guidelines and design processes and methods for urban stormwater drainage works in

Queensland, as well as considering environmental and legal aspects.

Each section has been prepared acknowledging that:

- certain design elements are essential to be complied with to achieve a satisfactory design solution;
- some design elements may only apply to certain parts of a local government area or may only apply to specific development applications; and
- other design elements exist which will result in a more highly sophisticated level of performance and have been included for their education role.

This has been achieved by the following organisation of the Design Elements:

General

Compliance with these elements is required to achieve an acceptable level of performance in planning, design, and development of residential projects.

Site Specific

Compliance with these elements is only required in special circumstances, where sufficient community interest warrants detailed consideration of them and/or a sophisticated residential planning, design, and development outcome is desired. These elements would usually be specified in specialised documents produced through community consultation, such as in conditions of rezoning and/or town planning consent, and/or provisions of a Development Control Plan. Alternatively, developers might wish to voluntarily comply with these elements to dispel perceived community concerns.

Advisory

Advisory design elements have also been included as an appendix. Compliance with these design elements is not required to achieve compliance with the Residential Design Guidelines. They have been included as they are considered to be 'desirable' design elements from the perspective of creating good design outcomes. However, due to the subjective nature of the design elements and the difficulty in specifying acceptable solutions, it is not considered appropriate that these design elements be required to be complied with to achieve an approval. Consequently, the decision to apply these design elements is to remain with the designer, rather than the approving authority.

TABLE 1.1: Applying the Subdivision Design Guidelines to Different Sizes of Subdivision

Size of Subdivision

Med = medium to large, neighbourhood size creating collector streets and above, typically > 100 lots

Sml = small, part of a precinct creating access streets, typically 10–100 lots

Minor = minor, no public streets created (<10 lots)

Element		Med	Sml	Minor
1	Neighbourhood Design	x		
2	Street Networks	x		
3	Public Open Space	x	x	x
4	Street Design	x	x	
5	Street Construction	x	x	
6	Utilities	x	x	x
7	Storm Drainage	x	x	x
8	Water Quality Management	x	x	x
9	Lot Layout	x	x	x

"x" = Indicates Element is applicable

1.1 Application of Design Guidelines

The Subdivision Guidelines apply to land subdivision for residential development purposes prior to building construction.

The Subdivision Guidelines Performance Criteria have been developed to apply to both community title and torrens title.

However, where a plan of development is required by the Planning Scheme to be developed in relation to future housing construction, the Subdivision Guidelines do not apply.

In that circumstance, the Integrated Development Guidelines are applicable.

In some cases, depending on the size of subdivision, not all Design Elements or Performance Criteria will apply.

Table 1.1 illustrates how the size of the development may impact on the Design Elements applicable.

The subdivision design should however be tested against each Design Element to ensure all applicable provisions have been addressed.

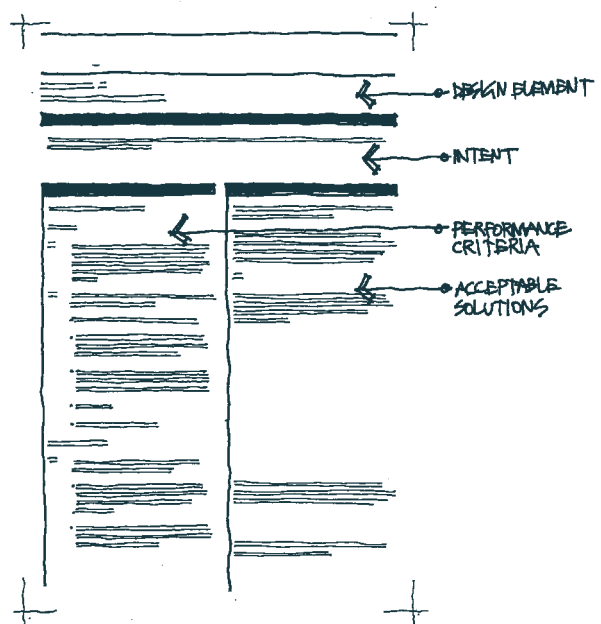

Figure 1: The layout of a typical page for a Design Element

1.2 The Performance Approach

The Queensland Residential Design Guidelines adopts a performance-based system of control. Instead of specifying prescriptive standards, it focuses on matters to be addressed (called Performance Criteria) in order to achieve a desired outcome (called Intent).

Such a performance-based system centred on objectives and desired outcomes, offers an opportunity for diversity and choice, and provides flexibility to respond to market needs and preferences, and changes in approaches and technology.

Performance-based regulation is enhanced if examples of ways in which the desired result can be achieved are indicated. Acceptable Solutions are provided as examples of what is considered acceptable, while not precluding other options.

The Acceptable Solutions illustrate ONE WAY only of meeting the associated Performance Criteria. The acceptability of other solutions is required to be demonstrated. This may be achieved with reference to built examples, plans and/or illustrations representing contemporary best practice in residential planning, design and development.

Each Design Element has a consistent format (refer figure 1). A concise statement of intent is at the top of the page (1). The left column sets the Performance Criteria (2) and the right column Acceptable Solutions (3) relates to the relevant Performance Criteria.

The Guidelines do not repeat the explanatory and background material included in AMCORD for each Design Element. This material however, should be referenced where alternative solutions are proposed or where clarity is required in relation to the source and/or intention of the Performance Criteria.

1 Intent

The Intent outlines the aim of the Design Element and reflects identified planning and policy requirements.

In complying with the Intent, an applicant must conform to all relevant Performance Criteria. Where Acceptable Solutions have been documented to cover specific Performance Criteria, designers can use these in satisfaction of the Performance Criteria.

2 Performance Criteria

Performance Criteria are general statements of the means of achieving the Intent. They are not meant to be limiting in nature. Instead, they provide designers and developers with an opportunity to develop a variety of design responses.

Not all Performance Criteria will be applicable to every development. In submitting a proposal for approval, the designer and developer must indicate those criteria not relevant to their particular development.

In other circumstances, some performance criteria may be found to conflict with other performance criteria. In these instances, "trade-offs" may need to be considered as part of the design and approval process in arriving at an acceptable solution.

3 Acceptable Solutions

Acceptable Solutions are provided as examples of what may enable the achievement of the Performance Criteria. They should not be interpreted as an alternative prescriptive form of regulation nor should they preclude other solutions.

Acceptable solutions may not be provided for all Performance Criteria. In those instances, solutions specific for each circumstance will need to be developed by the designer.

1.3 Site Analysis

A detailed and comprehensive site analysis is the foundation of any good design and should be carried out if the intent of these guidelines is to be achieved.

Specifically, the objective of the site analysis is to ensure that a coherent site layout and design is achieved which:

- identifies the constraints of the site;
- highlights the site's opportunities; and
- shows the important aspects of the surrounding environment.

The site analysis plan highlights a number of aspects which can be otherwise readily overlooked, namely:-

- the need for retaining walls and the impact on adjoining properties' amenity;
- redirection of overland flow paths; and
- clashes of services and building works.

The submission of a site analysis plan will assist in the development assessment process and is needed should more innovative design solutions be proposed. The site analysis plan should include at least:

- existing and proposed contours;
- where practicable, identification of previously filled areas;
- drainage paths adjoining and entering the site;
- all existing services and easements on the site or adjoining properties;
- all existing and proposed roadways; and
- existing buildings, fences, vegetation or other natural site features of identified conservation or heritage value.

In addition, other matters which may be relevant depending on the specific circumstance include:

- orientation, significant noise sources and micro-climate (eg: keeping potential for breezes);
- views to and from the site;
- prevailing winds; and
- built form and character of adjacent and nearby development.

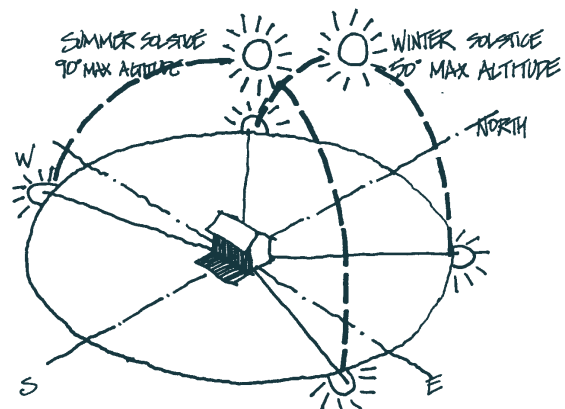

Figure 2: Solar path diagram

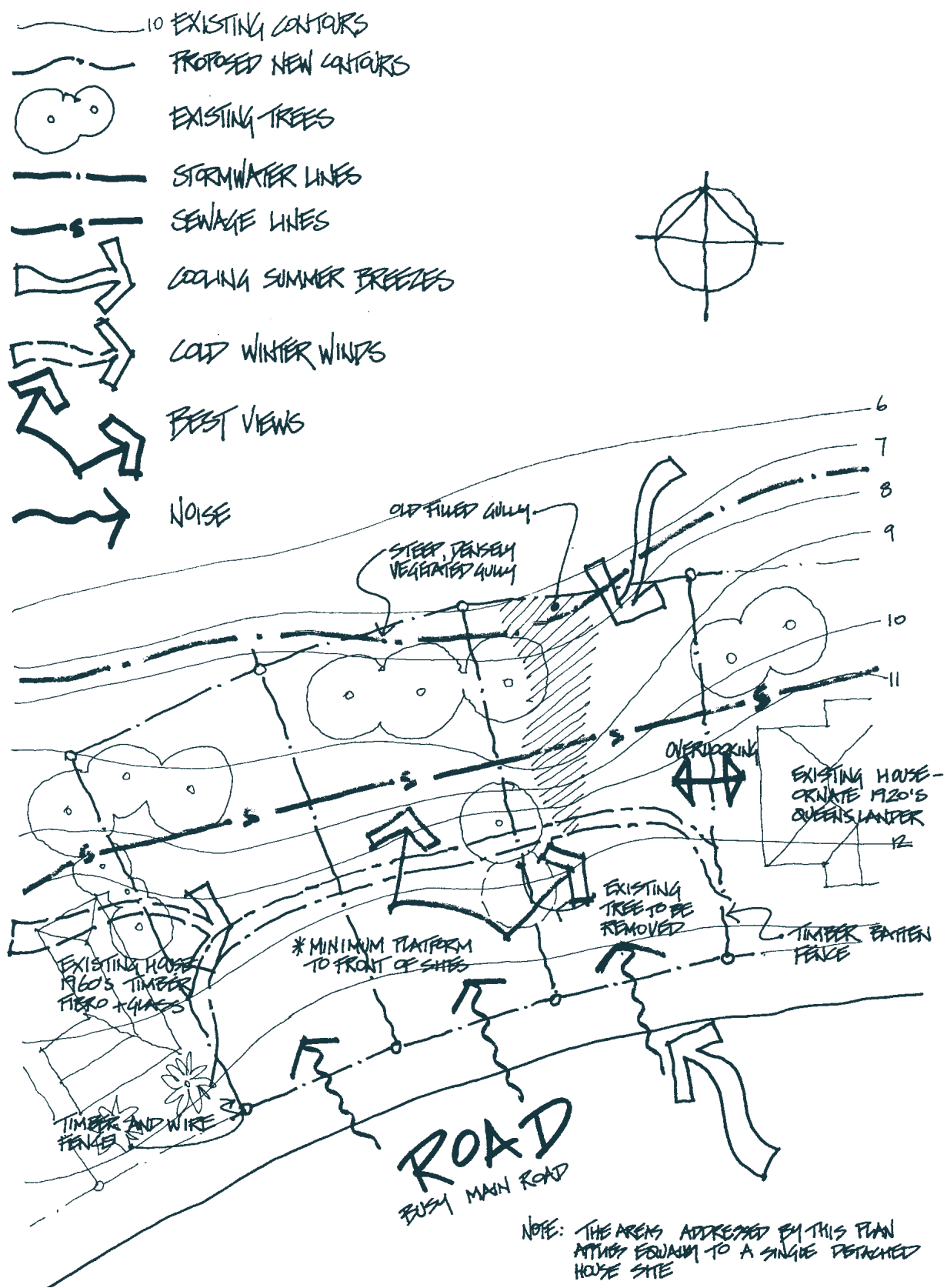

Figure 3: Typical site analysis plan

ELEMENT A1

Neighbourhood Design

INTENT

To provide safe, convenient and attractive neighbourhoods that meet the diverse and changing needs of the community. This encompasses offering a wide choice in good quality affordable housing and associated community and commercial facilities, providing for local employment opportunities, encouraging walking and cycling, minimising energy consumption, and promoting a sense of place through neighbourhood focal points and the creation of a distinctive identity which recognises and, where relevant, preserves the natural environment.

PERFORMANCE CRITERIA

The intent may be achieved where:

- P1** The subdivision layout gives a neighbourhood a strong and positive identity, by responding to site characteristics, setting, landmarks and views and through clearly readable street and open-space networks.
- P2** Neighbourhood identity is reinforced by locating community, retail and commercial facilities at focal points within convenient walking distance for residents.
- P3** The street network provides a high level of internal accessibility and good external connections for local vehicle, pedestrian and cycle movements, with traffic management to restrain vehicle speed, deter through-traffic and create safe conditions for other road users.
- P4** The vehicle, cyclist and pedestrian networks, land-use mix and lot density minimise fossil fuel use by reducing local vehicle trips, travel distances and speeds, maximising public transport effectiveness, and encouraging walking and cycling to daily activities.
- P5** The distribution and design of land uses minimise infrastructure costs.
- P6** The street and lot orientation and lot dimensions facilitate the siting and design of dwellings which conserve non-renewable energy sources and assist in design appropriate for the climatic conditions.

ACCEPTABLE SOLUTIONS

The Acceptable Solutions illustrate ONE WAY of meeting the associated performance criteria.

(in relation to P1 to P6)

There are no recommended Acceptable Solutions for this Element, as each situation requires an individual approach.

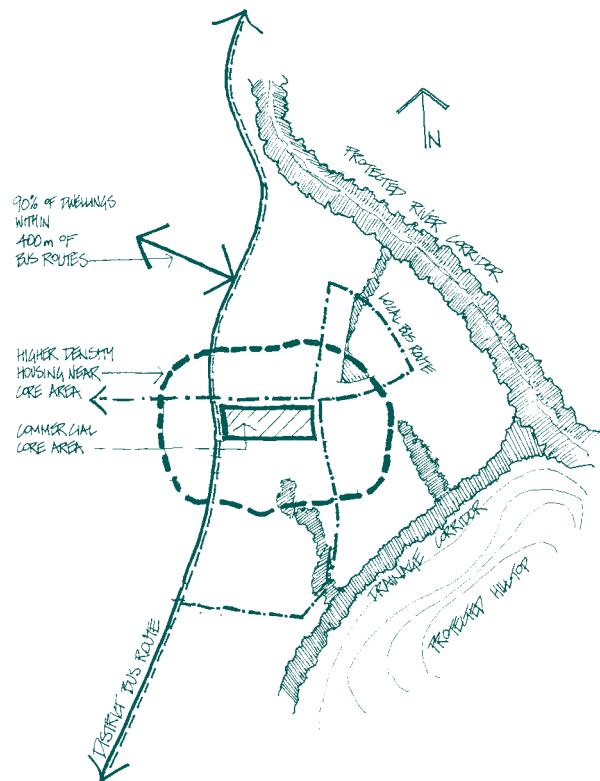

Figure 4: Neighbourhood design
Typical principles

ELEMENT A 1

Neighbourhood Design continued

PERFORMANCE CRITERIA

- P7** The street network caters for the extension of existing or future public transport routes to provide services that are convenient and accessible to the community.
- P8** The layout provides well-distributed public open spaces that contribute to the legibility and character of the development, provide for a range of uses and activities, are cost-effective to maintain, and contribute to stormwater management and environmental care.
- P9** The layout retains significant vegetation and habitat areas, incorporates natural and cultural features, minimises soil erosion and avoids development on flood-prone land.
- P10** The layout is integrated with the surrounding urban environment, complements existing attractive streetscapes and landscapes, and provides for shared use of public facilities by adjoining communities.
- P11** The layout enhances personal safety and perceptions of safety, and minimises potential for crime, vandalism and fear through achievement of surveillance by drivers of passing vehicles and pedestrians.
- P12** The pedestrian network is safe, attractive and efficient, running largely along public spaces (including streets and open spaces) fronted by houses, and avoiding uses that generate major breaks in surveillance on routes to and from public transport or those used at night.

ACCEPTABLE SOLUTIONS

- A7** At least 90% of dwellings are within 400m radial distance from an existing or potential bus route.
- A8.1** District parks, consisting of 3ha minimum area and containing a range of recreation settings, are provided within 2km of all dwellings.
- AND
- A8.2** Large local parks consisting of 0.4–1.0ha minimum area provided within 500m safe walking distance of 90% of all dwellings.
- AND
- A8.3** Small local parks consist of 0.2ha minimum area provided to serve neighbourhood needs within 300m safe walking distance of 90% of all dwellings.

ELEMENT A1

Neighbourhood Design *continued*

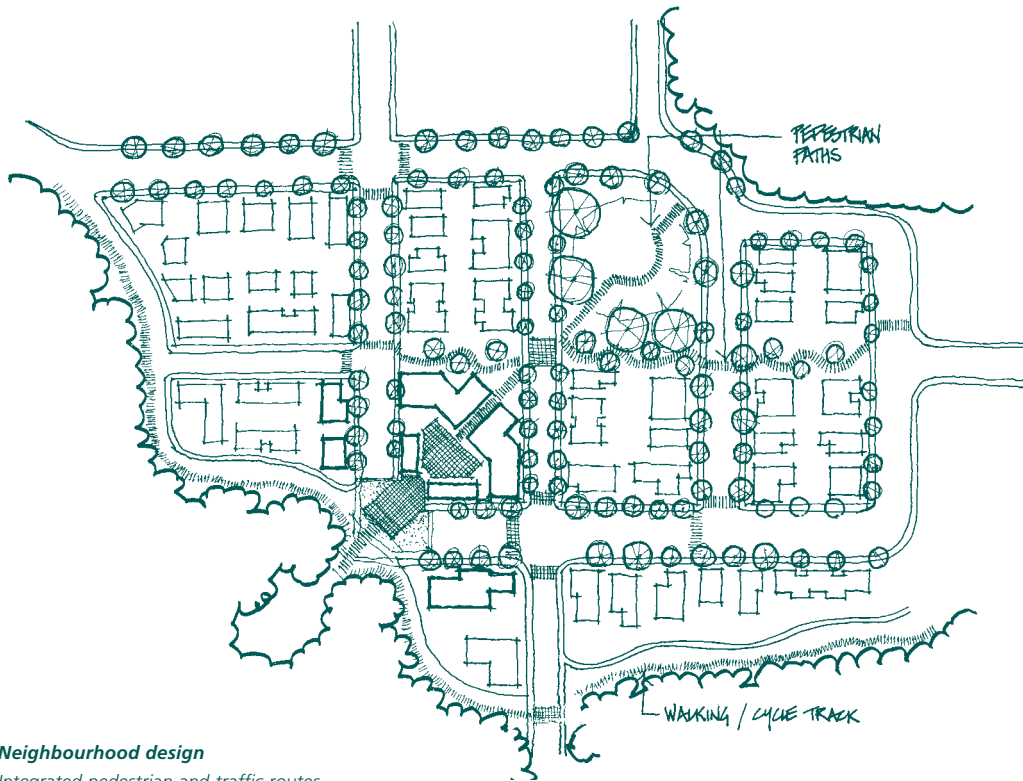

Figure 5: Neighbourhood design
Integrated pedestrian and traffic routes

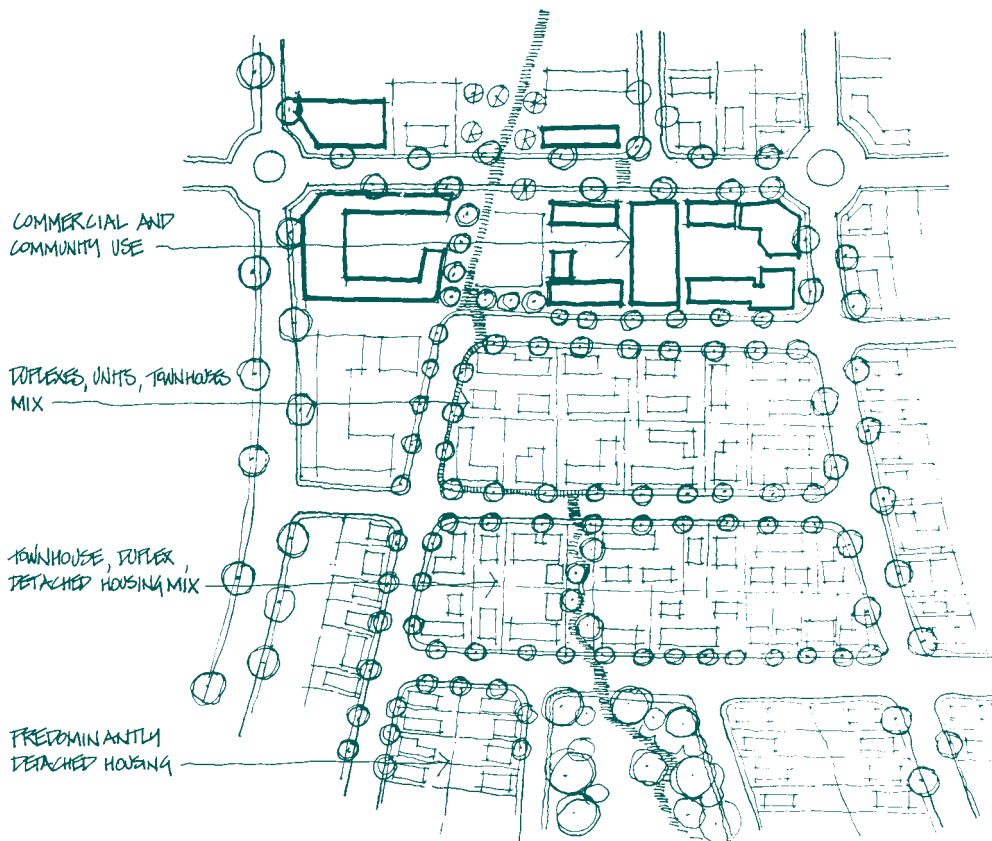

Figure 6: Neighbourhood design
Housing choice

ELEMENT A2

Street Networks

INTENT

To create street networks in which the function of each street is clearly identified, providing acceptable levels of access, safety and convenience for all users.

PERFORMANCE CRITERIA

The intent may be achieved where:

Function and structure

- P1** The street network has a clear structure and component streets conform to their function in the network.
- P2** The network has clear physical distinctions between each type of street. These distinctions are based on function, legibility, convenience, traffic volumes, vehicle speeds, public safety and amenity.
- P3** The design features of each type of residential street encourage driver behaviour appropriate to the primary function of the street in the network.

Safety, access and convenience

- P4** Junctions along residential streets are spaced to create safe and convenient vehicle movements.
- P5** The street network creates convenient movement for residents between their homes and higher-order roads.

Mode choice

- P6** The alignment and geometry of the streets that form identified bus routes allow for efficient and unimpeded movement of buses without facilitating high traffic speeds.
- P7** The street network facilitates walking and cycling within the neighbourhood and to local activity centres.

ACCEPTABLE SOLUTIONS

The Acceptable Solutions illustrate ONE WAY of meeting the associated Performance Criteria.

A defined street network plan exists which indicates the street network below the level of major collector street and development conforms with this plan.

OR

Where no defined street network plan exists development conforms with *Queensland Streets*.

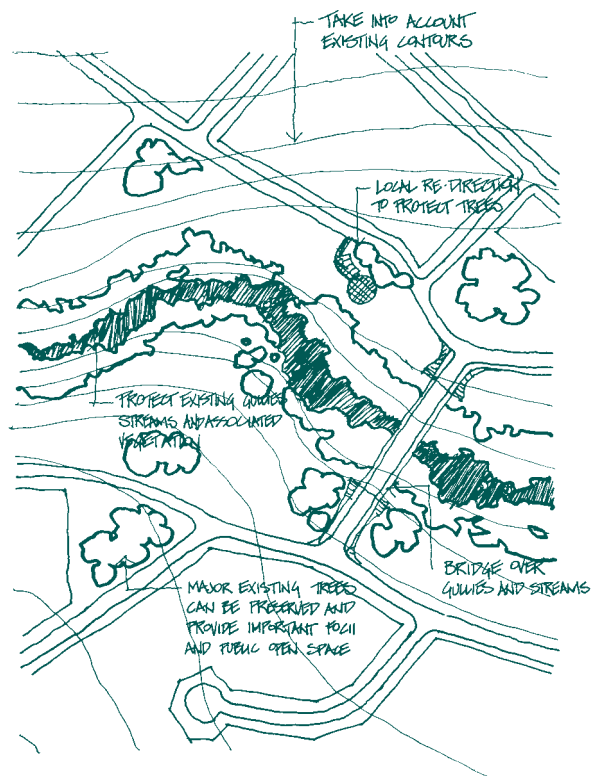

Figure 7: Street network designed to suit the site

ELEMENT A 2

Street Networks continued

PERFORMANCE CRITERIA

Urban design and character

- P8** The street network takes account of the topography and vegetation, respects any existing or potential site assets, and takes advantage of opportunities for views and vistas.
- P9** The street network takes account of the streetscapes that may be created or that already exist.
- P10** The street network is orientated, where practical, to promote efficient solar access for dwellings.
- P11** The street network takes account of natural drainage and open space systems.

Environmental protection

- P12** Traffic generated by a development is within the acceptable environmental capacity of the roads and streets.
- P13** Streets do not operate as through-traffic routes for externally-generated traffic, while limiting the length of time local drivers need to spend in a low-speed environment.
- P14** The street network is designed to reduce traffic speeds and volumes to acceptable levels, with most dwellings fronting streets with low volumes.
- P15** The impact of measures intended to restrain traffic speeds and/or volumes take account of the needs of other street users and adjoining dwellings.

Cost-effectiveness

- P16** Streets and carriageway widths and street lengths optimise the cost-effectiveness of the street network.
- P17** The network provides for the cost effective provision of public utilities.

ACCEPTABLE SOLUTIONS

ELEMENT A 3

Public Open Space

INTENT

To provide, where appropriate, public open space that meets user requirements for outdoor recreational and social activities and for landscaping that contributes to the identity and environmental health of the community.

PERFORMANCE CRITERIA

The intent may be achieved where:

- P1** The multi-functional role of public open space, and its use as a community facility and for stormwater management, is recognised and promoted.
- P2** Public open space provides:
- a range of recreation settings, corridors for community paths, and attractive urban environment settings and focal points;
 - adequate facilities to meet the needs of the community as reflected by indicators such as population density and demographic structure;
 - accessibility to users in conjunction with existing facilities;
 - acknowledgement of the opportunities and constraints presented by the physical characteristics of the land in the proposed use, landscaping and facilities;
 - opportunities for the incorporation of existing trees, rocks, streams and other sites of natural or cultural value, and linkage of habitats and wildlife corridors;
 - opportunities to link public open spaces into a legible network;

ACCEPTABLE SOLUTIONS

The Acceptable Solutions illustrate ONE WAY of meeting the associated Performance Criteria.

(in relation to P1 and P2)

- A1.1** Public open space is provided in accordance with an approved open space strategy, neighbourhood plan or development plan.

OR

(in partial satisfaction of P1 and P2)

- A1.2** Areas of public open space (incorporating drainage networks designed as part of multiple-use drainage systems) are provided to meet the statutory requirements of State and local authorities.

ELEMENT A3

Public Open Space *continued*

PERFORMANCE CRITERIA

- public safety and reasonable amenity of adjoining land users in the design of facilities and associated engineering works;
- for proposed responsibilities, maintenance requirements and costs;
- opportunities for regional or district open space to meet neighbourhood open space requirements;
- a clear relationship between public open space and adjoining land uses established by appropriate treatment including alignment, fencing, landscaping, and issues of security and surveillance; and
- avoidance of continual lengths of solid fencing along open space areas for security, surveillance, aesthetic and maintenance reasons.

ACCEPTABLE SOLUTIONS

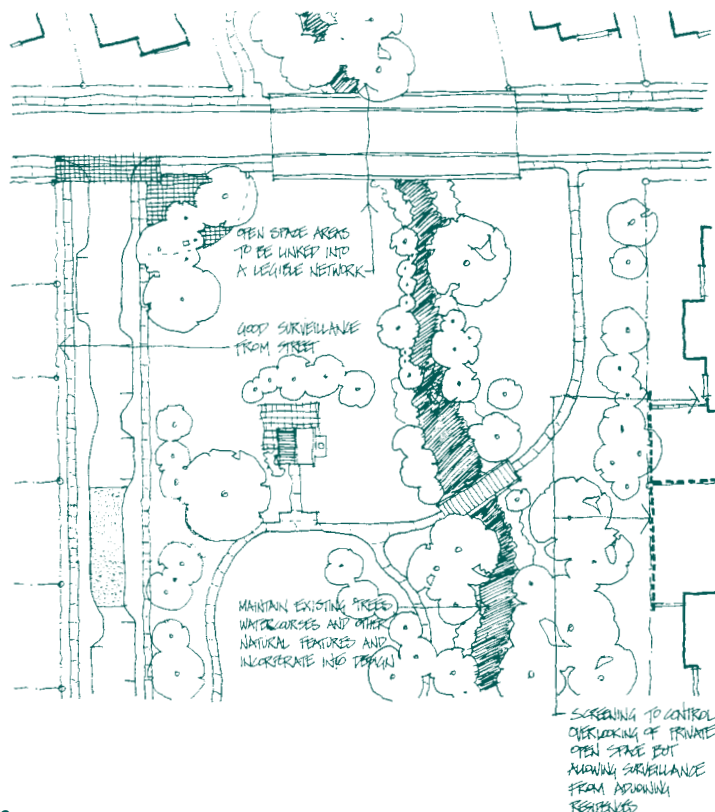

Figure 8: Public open space

ELEMENT A 4

Street Design

INTENT

To provide for streets that fulfil their designated functions within the street network, accommodate public utility services and drainage systems, and create a safe and attractive environment in a cost effective manner.

PERFORMANCE CRITERIA

The intent may be achieved where:

Function and width

- P1** The design features of each type of residential street convey its primary function.
- P2** The street reserve width is sufficient to cater for all street functions, including:
- safe and efficient movement of all users;
 - provision for parked vehicles;
 - provision of landscaping;
 - location, construction and maintenance of public utilities.
- P3** The verge width is sufficient to provide for special site conditions and future requirements.

Designing for safety

- P4** The design facilitates safe use by pedestrians, particularly people with disabilities, the aged and children, by:
- providing a carriageway width which allows vehicles to proceed safely at the operating speed intended for that level of street;
 - making allowances for restrictions caused by on-street parking;
 - providing a horizontal and vertical alignment which is not conducive to excessive speeds;
 - promoting the safety of pedestrians where it is intended that they use the carriageway at bus stops and other crossing points;
 - promoting the safety of cyclists in streets and at crossing points.

ACCEPTABLE SOLUTIONS

The Acceptable Solutions illustrate ONE WAY of meeting the associated Performance Criteria.

Development conforms with the provisions of Queensland Streets.

ELEMENT A 4

Street Design continued

PERFORMANCE CRITERIA

Designing for safety (continued)

P5 Speed reduction techniques and devices are used to achieve desired speeds, as part of a design for the whole street environment, and include the following principles:

- slow points including either horizontal or vertical deflection are designed to slow traffic to design speeds;
- slow points and carriageway narrowings are designed to take into account the needs of cyclists, by ensuring speed compatibility, adequate space for concurrent passage or off-street diversions;
- landscape design, on-street parking and streetscape design are used to complement speed restriction measures;
- speed restriction techniques and devices are not used in isolation;
- the verge, when considered in conjunction with the horizontal alignment and permitted fence, wall and other property frontage treatments, provides safe sight distances, taking into account expected vehicle speeds and pedestrian and cyclist movements.

P6 Safe sight distances, based on the speeds at which vehicles may travel in the street, exist at access points to properties, pedestrian and cyclist crossings and at junctions and intersections.

Access and verge

P7 The carriageway width, together with the verge width and crossover dimensions, allows for unobstructed and efficient access to individual lots and sites, even when a car is parked on the opposite side of the street.

P8 Driveway egress movements do not create a safety hazard.

ACCEPTABLE SOLUTIONS

ELEMENT A 4

Street Design continued

PERFORMANCE CRITERIA

Geometric design

- P9** Bus routes have a carriageway width to allow for the movement of buses unimpeded by parked cars, safely accommodate cyclists and avoid cars overtaking parked buses.
- P10** The horizontal and vertical alignments and crossfall reflect physical land characteristics and major drainage functions, while satisfying safety criteria.
- P11** Geometric design for intersections, roundabouts and slow points is consistent with the vehicle speed intended for each street.
- P12** Kerb radii at intersections and junctions are kept to a minimum, subject to satisfying required turning templates (including those for service and emergency vehicles), to keep pedestrian crossing distances to a minimum and to control the speeds of turning vehicles.
- P13** Siting conditions on land abutting major collector streets ensure that all vehicles can enter or leave the street in a forward direction.

On-street parking

- P14** Resident and visitor carparking is provided according to projected needs, taking into account:
- total parking demand;
 - parking opportunities within allotments; and
 - non-residential and external parking generators.
- P15** Parking provision shall be designed to ensure:
- no obstruction or danger to the passage of vehicles on the carriageway, or to pedestrians;
 - efficient design of parking spaces and accesses; and
 - convenient vehicle access to allotments.

ACCEPTABLE SOLUTIONS

ELEMENT A4

Street Design *continued*

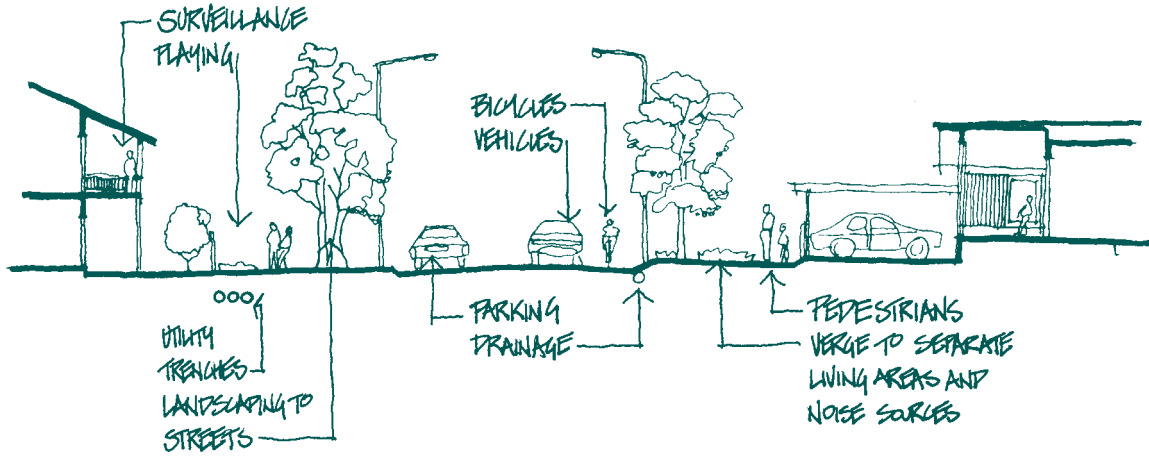

Figure 9: Typical street cross section

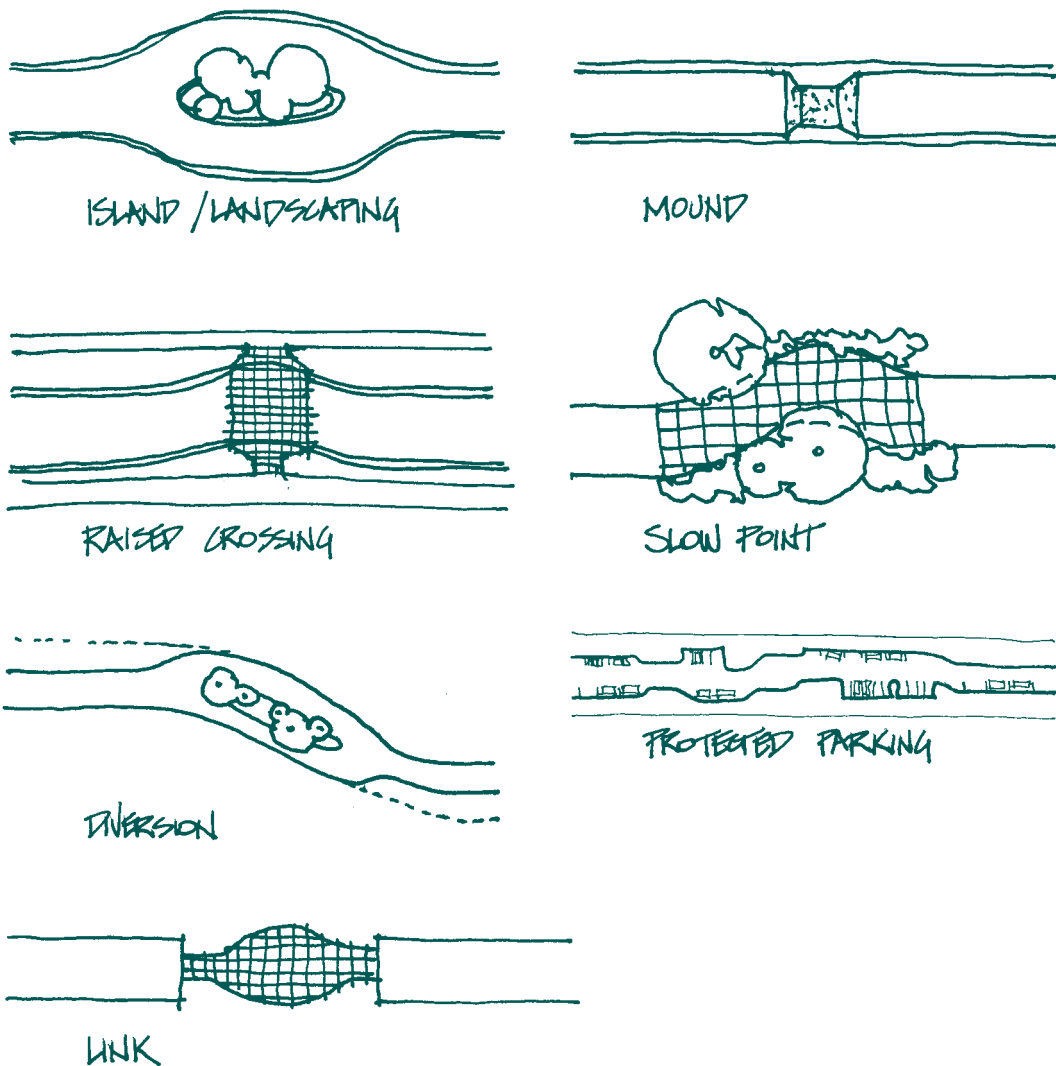

Figure 10: Speed reduction by various means

ELEMENT A 5

Street Construction

INTENT

To construct streets that support the design intentions without unnecessary construction and whole-of-life-cycle costs.

PERFORMANCE CRITERIA

The intent may be achieved where:

- P1** The pavement, edging and landscaping support the specified functions and amenity of the street.
- P2** The pavement edge:
- controls vehicle movements where applicable by delineating the carriageway for all users;
 - assists in reducing stormwater run-off into the reticulated system, by conveying stormwater to a desired outlet;
 - provides for people with disabilities, by allowing safe passage of wheelchairs and other mobility aids.
- P3** Street pavement surfaces are well designed and durable enough to carry wheel loads of travelling and parked vehicles; ensure the safe passage of vehicles, pedestrians and cyclists; the discharge of stormwater run-off, and the preservation of all-weather access; and allow for reasonable travel comfort.
- P4** Consistent with the previous Performance Criteria, public street construction and whole-of-life-cycle costs are kept low.

ACCEPTABLE SOLUTIONS

The Acceptable Solutions illustrate ONE WAY of meeting the associated Performance Criteria.

- A1** Pavement and landscape materials are used, where appropriate, to distinguish different street functions.
(in partial satisfaction of P2)
- A2** Pavement edges at locations where pedestrians are encouraged to cross, are constructed for wheelchair access and to assist sight-impaired people in accordance with AS1428.
- A4.1** Flexible pavement construction is based on the ARRB residential street pavement design method using equivalent standard axle loadings and a 20 year design life (ARRB, 1989).
- AND
- A4.2** Concrete pavement construction is based on the Cement and Concrete Association of Australia's design table, and interlocking block pavement construction is based on the ARRB interlocking block pavement design method.
- A4.3** Kerb and channel profiles accord with Australian Standard 2876-1987 or as specified by the relevant authorities.

ELEMENT A 6

Utilities

INTENT

To ensure that residential areas are adequately serviced with sewerage, water fire-fighting, electricity, gas, street lighting and communication services in a timely, cost-effective, coordinated and efficient manner that supports sustainable development practices.

PERFORMANCE CRITERIA

The intent may be achieved where:

- P1** The design and provision of public utilities, including sewerage, water, electricity, gas, street lighting, and communication services, are cost-effective over their life cycle and incorporate provisions to minimise adverse environmental impact in the short and long term.
- P2** Compatible public utility services are co-located in common trenching in order to minimise the land required and the costs for underground services.
- P3** Transportation, treatment and disposal of sewage wastes are to the satisfaction of the local authority or relevant servicing authority, and the relevant environmental regulator.
- P4** Development occurs within locations where there is an adequate water supply for domestic and fire fighting purposes.
- P5** Development is staged to ensure that each stage is fully serviced before a new area is released.
- P6** Water supply and sewerage networks are accessible, easy to maintain, and cost-effective based on life-cycle costs.
- P7** The selection of materials used for the construction of water supply and sewerage networks is determined by suitability, durability, ease of maintenance and cost-effectiveness, considering whole-of-life-cycle costing, achieving for example beneficial environmental impacts and energy savings from new materials and technologies.
- P8** Adequate buffers are maintained between utilities and houses to protect residential amenity and health.
- P9** The use of local effluent treatment plants to recycle and reuse waste is achieved in areas where connections to large sewage treatment plants are less economically viable.

ACCEPTABLE SOLUTIONS

The Acceptable Solutions illustrate ONE WAY of meeting the associated Performance Criteria.

(in relation to P1 to P9)

- A1.1** The location, design and proposed construction of sewerage facilities, water supply mains and fixtures, electricity, gas, communication services and street lighting are in accordance with a development plan.
- OR
- A1.2** The design and provision of public utilities, including sewerage, water, electricity, gas, street lighting and communication services conform to the cost-effective and environmental performance measures of the relevant servicing authorities.
- AND
- A1.3** The design and construction of sewerage facilities, water supply mains and fixtures, electricity, communications, gas and street lighting are undertaken by properly qualified personnel.
- AND
- A1.4** The distribution system for all services will be in place before the first houses are occupied.

ELEMENT A 6

Utilities continued

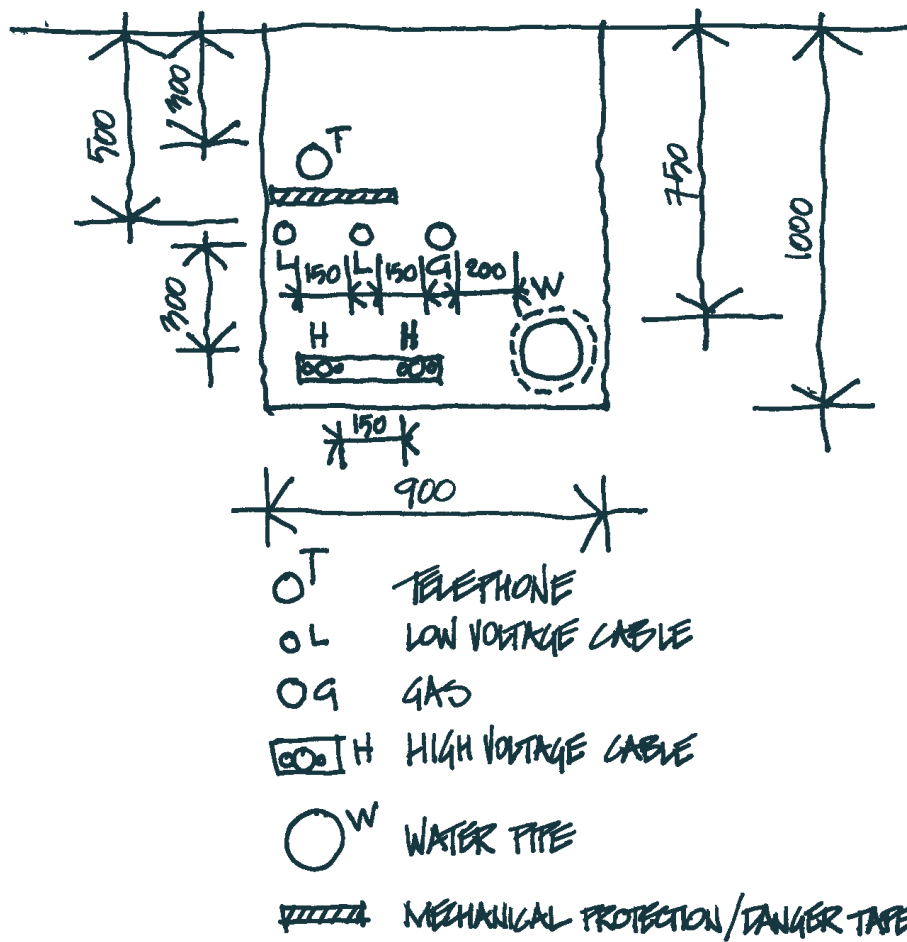

Figure 11: Common trenching

ELEMENT A 7

Storm Drainage

INTENT

To provide major and minor drainage systems which adequately protect people and the natural and built environments, at an acceptable level of risk and in a cost-effective manner, in terms of initial cost and maintenance, and which contribute positively to environmental enhancement of catchment areas.

PERFORMANCE CRITERIA

The intent may be achieved where :

Major system

- P1** The major storm drainage system has the capacity to safely convey stormwater flows result from the relevant design storm under normal operating conditions.
- P2** The major system has the capacity to convey safely, but without significant property damage, stormwater flows resulting from more extreme events than its design storm.
- P3** Ground-floor levels of proposed dwellings can be located above the design flood level to provide protection of property in accordance with the accepted level of risk.
- P4** Floodways are developed such that there is a low risk of property damage.
- P5** The major system is designed to ensure that there are no flow paths which would increase risk to public safety and property.
- P6** Community benefit is maximised through the retention of natural streams and vegetation wherever practicable, the incorporation of sports grounds and other less flood-sensitive land uses into the drainage corridor and the placement of detention and retention basins for amenity and function.

Minor system

- P7** The minor storm drainage system has the capacity to control stormwater flows under normal operating conditions for the relevant design storm without blockage.
- P8** Drainage networks are well-defined to ensure there are no hidden flow paths which could reduce their capacity to convey design flows.

ACCEPTABLE SOLUTIONS

The Acceptable Solutions illustrate ONE WAY of meeting the associated Performance Criteria.

Major system

(in relation to P1 to P6)

- A1.1** The design and construction of the major storm drainage system are in accordance with a plan of development and the requirements of the relevant authorities.

OR

Development conforms with the provisions of Queensland Urban Drainage Manual except that:

- a) the major system has the capacity to safely convey stormwater flows under normal operating conditions and partial minor system blockage for ARI = 50 years.

AND

- b) Flows within the street are limited in depth and velocity by the formula

$$d_g V \text{ is } < \text{or} = 0.9 \text{ m}^2/\text{S}$$

or longitudinal flow

$$d_g V \text{ is } < \text{or} = 0.6 \text{ m}^2/\text{S}$$

for cross flow where a vehicle is likely to be washed off the roadway into the drainage system

$$d_g V \text{ is } < \text{or} = 0.4 \text{ m}^2/\text{S}$$

for cross flow where a pedestrian is likely to be washed into the drainage system

[where d_g = kerbside flowdepth (m)]

ELEMENT A 7

Storm Drainage continued

PERFORMANCE CRITERIA

Minor system (continued)

- P9** The minor system design minimises undesirable ponding for a prolonged period resulting from the relevant design storm.
- P10** The design of the minor system takes full account of existing downstream systems.
- P11** The minor system design allows for the safe passage of vehicles at reduced speed on streets which have been affected by runoff from the relevant design storm.
- P12** The minor system is accessible and easily maintained.
- P13** Where a portion of the minor system lies within a site, access is available for maintenance.
- P14** The selection of materials used for the construction of the minor system is based on their suitability, durability, maintainability and cost-effectiveness.

ACCEPTABLE SOLUTIONS

Minor system

(in relation to P7 to P14)

- A7.1** The design and construction of the minor system is in accordance with a plan of development and the requirements of the relevant authorities.

OR

(in relation to P7 to P10)

Development conforms with the provisions of the Queensland Urban Drainage Manual.

ELEMENT A 8

Water Quality Management

INTENT

To provide water quality management systems which ensure that disturbance to natural stream systems is minimised and stormwater discharge to surface and underground receiving waters, both during construction and in developed catchments, does not degrade the quality of water in the receiving domains.

PERFORMANCE CRITERIA

The intent may be achieved where:

- P1** Adequate provision is made for measures during construction to ensure that the land form is stabilised and erosion is controlled.
- P2** The system design optimises the interception, retention and removal of water-borne pollutants through the use of appropriate 'fitness for use' criteria, prior to their discharge to receiving waters.
- P3** The system design minimises the environmental impact of urban run-off on surface receiving water quality and on other aspects of the natural environment, such as creek configuration and existing vegetation, by employing all possible techniques which are technically appropriate and effective in reducing run-off and pollution travel in the catchment.
- P4** The system design minimises the environmental impact of urban run-off, diverted underground, on groundwater quality.
- P5** The system design ensures the continuation, in healthy condition, of a wide diversity of wetland environments in the urban landscape.
- P6** Sewage overflows into the stormwater system are prevented.
- P7** Point sources of pollution in the catchment should be identified and their impact minimised until they can be eliminated.

ACCEPTABLE SOLUTIONS

The Acceptable Solutions illustrate ONE WAY of meeting the associated Performance Criteria.

(in relation to P1 to P7)

- A1.1** The design and proposed implementation of the water quality control system are in accordance with a development plan and the requirements of the relevant authorities.

OR

(in partial satisfaction of P1 to P7)

- A1.2** The full range of appropriate practices and devices reviewed in Planning and Management Guidelines for Water-sensitive Urban (Residential) Design (Whelans et al. 1994) are addressed.

AND

- A1.3** The design of the water pollution minimisation system is undertaken and certified by properly qualified personnel using recognised and locally accepted hydrologic, hydraulic, hydrogeological, soils, water quality and biological data and design methodologies.

- A1.4** Water pollution control ponds or wetlands should be developed (where appropriate) for final treatment before discharge to the wider environment and should be sited to minimise impacts on the natural environment.

AND

- A1.5** Appropriate water quality criteria in accordance with 'fitness for use' requirements should be applied to all stormwater diverted underground to recharge aquifers.

AND

- A1.6** Litter reduction education programs, frequent street sweeping and regular pit cleaning operations should be carried out.

ELEMENT A 9

Lot Layout

INTENT

To provide a range and mix of lot sizes to suit a variety of dwelling and household types, with areas and dimensions that meet user requirements; and to provide lots that are oriented where practicable to enable microclimate management, including the application of energy conservation principles.

PERFORMANCE CRITERIA

The intent may be achieved where:

Size

- P1** Lots have the appropriate area and dimensions for the siting and construction of a dwelling and ancillary outbuildings, the provision of private outdoor space, convenient vehicle access and parking.
- P2** Lot size and dimensions take into account the slope of the land and the desirability of minimising earthworks/retaining walls associated with dwelling construction.
- P3** Lot size and dimensions enable dwellings to be sited to:
- protect specified natural or cultural features;
 - acknowledge site constraints including soil erosion and bushfire risk;
 - retain special features such as trees and views where practical.
- P4** Lot sizes meet the projected requirements of people with different housing needs, and provide housing diversity and choice.

User requirements

- P5** Lot frontages are orientated to streets and open spaces so that personal and property security, deterrence of crime and vandalism, and surveillance of footpaths and public open space are facilitated.

Orientation and energy

- P6** Lots are orientated to facilitate the siting of dwellings to take advantage of microclimatic benefits, and have dimensions to allow adequate on-site solar access and access to breezes (especially in the hot-humid tropics), taking into account likely dwelling size and the relationship of each lot to the street.

ACCEPTABLE SOLUTIONS

The Acceptable Solutions illustrate ONE WAY of meeting the associated Performance Criteria:

Size

(in partial satisfaction of P1)

- A1.1** Lots with an area of greater than 450m² are capable of containing a rectangle measuring 10m by 15m behind the street setback (or 9m by 15m where a boundary wall is nominated as part of the building envelope).
- AND
- A1.2** Lots with an area between 300m² and 450m² are capable of containing a rectangle measuring 9m by 15m behind the street setback.
- AND
- A1.3** Lots with an area less than 300m² are square or rectilinear in shape.
- AND
- A1.4** For "battleaxe" lots the access way shall be a minimum of 4m wide. The rear lot area and dimensions, exclusive of the access way satisfies A1.1 or A1.2 or A1.3. (Where adjoining "battleaxe" lots occur, joint use of a single driveway is an acceptable cost-effective solution).
- (In partial satisfaction of P2)*
- A2** Lots with an area of 450m² or less are located on land with a slope of less than 1 in 10 across the road frontage of the lot and 1 in 15 perpendicular to the road frontage.

ELEMENT B1**Bushfire Protection****INTENT**

To reduce the level of fire risk associated with building in bushfire-prone areas by adopting suitable passive and active protection measures relating to siting, layout, design and construction techniques, and landscaping.

PERFORMANCE CRITERIA

The intent may be achieved where:

- P1** Each dwelling site is provided with a safe and secure water supply for fire fighting and protection.
- P2** Landscaping is designed to provide protection to buildings and not increase the level of bushfire risk.
- P3** The land division is designed to provide for a fuel-modified buffer area and the creation of building sites that minimise the risk of fire.
- P4** The road layout, design and construction take account of the needs of emergency vehicles and possible evacuation.

ACCEPTABLE SOLUTIONS

There are no recommended Acceptable Solutions for this Element, as each situation requires an individual approach.

DEFINITIONS

Acceptable Solution means an example of what may satisfy the relevant Performance Criteria (they should not preclude other solutions).

Access place means a minor cul-de-sac street providing local residential access, with shared traffic, pedestrian and recreation use.

Access street means a street providing local residential access with shared traffic, pedestrian and recreation use with local traffic access priority.

AMCORD means the Australian Model Code for Residential Development – A national resource document for residential development – November 1995.

AS means Australian Standard.

Balcony means any balustraded platform, 0.3metres or more above adjacent finished ground level, either cantilevered or supported over open space, with access from the building via a door or window and with a minimum width of 1 metre.

BCA means Building Code of Australia.

Building envelope means a diagram drawn on a lot of a subdivision plan to the requirements of the Responsible Authority defining the limits for the siting and/or wall height of any dwellings and/or outbuildings, private open space, driveways and/or garages/carports.

Building height means the distance between natural surface level of the ground and the apex of a building's roof, but not including any receiving antennae, chimneys or flues.

Carriageway means the area of street or road reserve which is provided for the movement or parking of vehicles.

Casual surveillance refers to the ability to informally observe an area to enhance the level of security.

Collector Street – A street providing for local residential access and local traffic movement within performance limits defined in Queensland Streets.

Communal open space means usable community open space for recreation and relaxation of residents of a housing development and which is under the control of a body corporate or equivalent.

Communal street means the carriageway providing access to a housing development and which is under the control of a body corporate or equivalent.

Community Title refers to title given under the provisions of the Body Corporate and Community Management Act 1997 (BCCM Act) (formerly known as 'group title' under the Building Units and Group Titles Act 1980, which has been replaced by the BCCM Act).

Crossover refers to the paved accessway between the carriageway of a street and a development site.

Detached dwelling means a separate house on an individual lot (including a community title lot).

Development Area means an area identified as having potential for housing following strategic planning and study.

Duplex means a building comprising two attached dwellings on the same lot.

Established area means an existing neighbourhood where the vast majority of land is developed.

Flat or apartment (including attached to a shop, office etc) includes one or more of the following:

- units constructed over the top of each other;
- shared communal open space in lieu of or as well as private open space;
- shared parking/access arrangements;
- attached to a detached dwelling (with shared access/site facilities).

Frontage means the street alignment at the front of a lot and in the case of a lot that abuts two or more streets, the boundary of which, when chosen, would enable the lot to comply with these provisions.

Habitable room means a room used for normal domestic activities that includes:

- a bedroom, living room, lounge room, music room, television room, kitchen, dining room, sewing room, study, playroom and sunroom,

but excludes:

- a bathroom, laundry, water closet, food storage pantry, walk-in wardrobe, corridor, hallway, lobby, photographic darkroom, clothes drying room, and other spaces of a specialised nature occupied neither frequently nor for extended periods.

Height of a wall at any point for the purpose of determining its setback from a boundary means the vertical distance between the top of the eaves at the wall line, parapet or flat roof (not including a chimney), whichever is the highest, and the natural ground level of the lot boundary at a point at right-angles to the wall. Where a skillion roof occurs, the height shall be measured as the median height of the wall. When a triangular gable roof occurs, the heights shall be measured as the height of the wall together with one-third of the vertical height of the gable.

DEFINITIONS continued

Infill housing is a general term used for new housing in existing residential areas and usually involving the use of a vacant site or the removal of an existing dwelling to enable construction of a larger number of dwellings.

Intent (or Element Intent) means a statement of the desired outcomes to be achieved in the completed development, relating to particular Design Elements.

Landscape plan means a plan or document outlining the extent, type and location of proposed landscaping and planting.

Lot means an area of topographical space shown on an approved plan of subdivision and on which it is intended to construct a dwelling or dwellings.

Multi-unit dwellings means the development of more than one dwelling on a site where facilities are shared (eg access, parking, communal open space/facilities).

Nature strip refer to verge.

Outermost projection means the outermost projection of any structural part of a building or other structure including, in the case of a roof, the outside face of the fascia, or the roof structure where there is no fascia, but does not include any rainwater fittings, ornamental or architectural attachment.

Performance Criteria means criteria to be used in the preparation, submission and assessment of development proposals for measuring performance of the proposals against the Element Intent.

Plan of Development means a plan approved as part of a planning process which identifies the precise conditions for housing and other activities.

Private open space means an open area of land or building attached to a dwelling (eg balcony or roof garden) intended for the exclusive use of the occupants of the dwelling, and located and designed so as to offer visual privacy to the occupants.

Public open space means land used or intended for use for recreational purposes by the public and includes parks, public gardens, riverside reserves, pedestrian and cyclist accessways, playgrounds and sports grounds.

Setback means the shortest distance measured horizontally from the outermost projection of the building or other structure concerned to the vertical projection of the boundary of the allotment.

Site analysis involves the identification and analysis of the existing urban character and adjacent properties to assist in understanding the locality and the development of a range of appropriate design responses.

Site Analysis Plan means a plan which demonstrates an appreciation of a site and its context to identify opportunities and constraints on site layout and design. The plan may include information on topography and services, existing buildings on site, vegetation on site, adjoining property conditions, views, noise sources and street character and context.

Site density means the ratio of dwellings to the area of the site they occupy (including communal streets and communal open space).

Site means the lot(s) of land on which a building stands or is to be erected.

Storey means a space within a building which is situated between one floor level and the floor level next above, or if there is no floor above, the ceiling or roof above. It does not include a room contained wholly within the roof space or a parking area contained wholly within a basement which is below the natural ground level.

Street – Any street, lane, square, court, alley and other carriageways whose primary purpose is providing access to residential buildings.

Street pavement see Carriageway.

Street reserve means the land set aside for a street pavement and verge.

Streetscape plan means the portion of the development plan showing the visible components within a street (or part of a street) between facing buildings, including the form of buildings, setbacks, fencing, landscaping, driveway and street surfaces, utility services and street furniture such as lighting, signs, barriers and bus shelters.

Subdivision means the division of a parcel of land into two or more parts for the purpose of enabling any of the lots to be disposed of separately.

Verge means that part of the street or road reserve between the carriageway and the boundary of adjacent lots (or other limit to street reserve). It may accommodate public utilities, footpaths, stormwater flows, street lighting poles and planting.

Wall height refer to Height of Wall.

Weighting means a process of determining priorities for various Design Elements and Performance Criteria in the consideration of designing and assessing development proposals.

Window includes a roof skylight, glass panel, glass brick, glass louvre, glazed sash, glazed door, translucent sheeting or other device which transmits natural light directly from outside a building to the room concerned.

REFERENCES

Australian Road Research Board (ARRB) (1989): Structural design guide for residential street pavements, Special Report No. 41 prepared by P.J. Mulholland.

Department of Primary Industries-Water Resources (DPI), Institute of Municipal Engineering Australia, Qld. Division, Brisbane City Council (November 1994): Queensland urban drainage manual, (QUDM) prepared by Neville Jones and Associates Pty Ltd and Australian Water Engineering.

Institute of Municipal Engineering Australia, Qld Division (IMEAQ) (1993, incorporating 1996 update): Queensland streets-design guidelines for subdivisional streetworks, prepared by Weathered Howe Pty Ltd.

Whelans and Halpern Glick Maunsell (1994): Planning and management guidelines for water-sensitive urban (residential) design, Report prepared for Dept Planning and Urban Development, Water Authority of WA and EPA, Perth.

APPENDIX

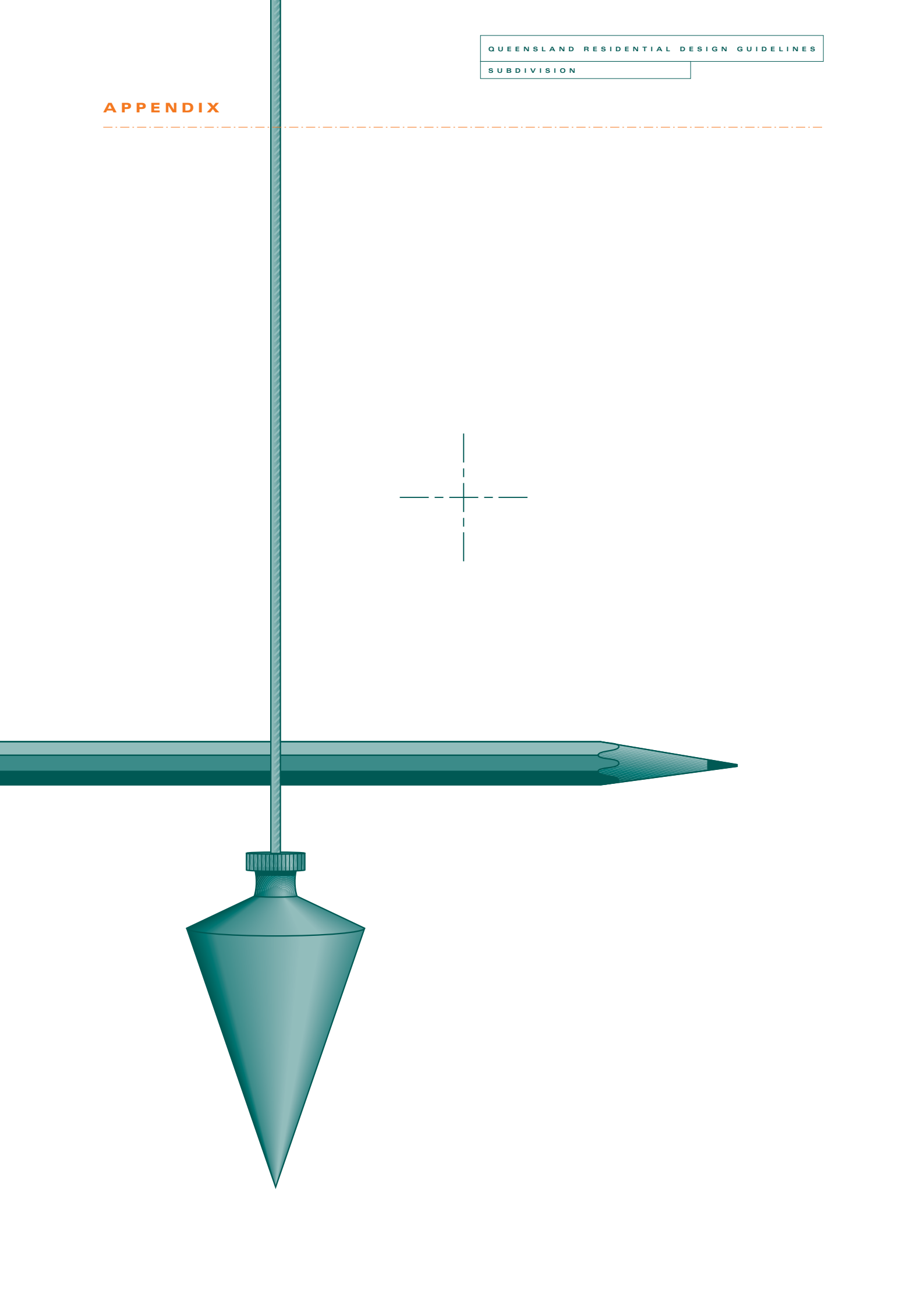

ELEMENT C1

Stormwater Harvesting

INTENT

To develop the resource potential of stormwater to supply a range of second-quality water uses presently met from town supply systems.

PERFORMANCE CRITERIA

The intent may be achieved where:

- P1** Direct stormwater use systems are effective in collecting, storing and applying appropriate physical treatment to storm run-off for immediate use.
- P2** Indirect stormwater use systems are effective in collecting, applying physical treatment to, storing and retrieving storm run-off for use as required.
- P3** Stormwater use systems provide the community with opportunities to reduce mains water use.
- P4** Stormwater use systems provide the community with water for second-quality uses, leading to cost reductions.
- P5** Stormwater use systems which incorporate constructed wetlands environments make positive contributions to urban amenity.
- P6** Stormwater use systems are effective in reducing the costs of downstream storm drainage.
- P7** Aquifers chosen for long-term storage of storm run-off can be effective components of comprehensive direct and indirect stormwater use schemes.

SUGGESTED SOLUTIONS

There are no recommended Suggested Solutions for this Element, as each situation requires an individual approach.

FEEDBACK FORM

The Queensland Department of Local Government and Planning is committed to ensuring that the Queensland Residential Design Guidelines are user-friendly and accessible. We would appreciate you taking a few moments to answer the following questions and returning this form to our Reply Paid address. We will use the information we receive to rewrite future editions of the Guidelines.

Please indicate your area of specialisation:

- Town Planner
Developer
Building Designer
Surveyor
Builder
Architect
Engineer
Other

Were the Guidelines easy to understand?

Yes No
If no, why not?

Were the graphics throughout the Guidelines useful?

Yes No
If no, why not?

How did you find out about the Queensland Residential Design Guidelines?

Dashed lines for text entry

Where did you obtain a copy of the Guidelines?

Dashed lines for text entry

Have you used the CD rom version of the Guidelines?

Yes No
If yes, what did you think about the format and user-friendliness of the CD?

Dashed lines for text entry

Were the Guidelines easy to use?

Yes No
If no, why not?

Dashed lines for text entry

If no, why not?

Dashed lines for text entry

FEEDBACK FORM

Have the Guidelines been a useful resource for your business?

Yes No

If yes, which areas have been of particular interest and assistance?

If no, why not?

Is there any additional information you would like to have seen included in the Guidelines?

Yes No

If yes, which additional information?

Will you continue using the Guidelines?

Yes No

If no, why not?

Would you recommend the Guidelines to other colleagues?

Yes No

If no, why not?

Would you be interested in obtaining further editions of the Guidelines?

Yes No

If no, why not?

Please provide an overall rating for the Guidelines?

Low 1 2 3 4 5 6 High

Please provide your contact details (and the details of other interested parties) if you/they would like to be added to the mailing list to obtain information about the Queensland Residential Design Guidelines and other Planning information prepared by the Department of Local Government and Planning.

Further comments

Please send to:

REPLY PAID 97
Queensland Department of
Local Government and Planning
PO Box 187
Brisbane Albert Street Q 4002